

MTB & Road Disc Brake

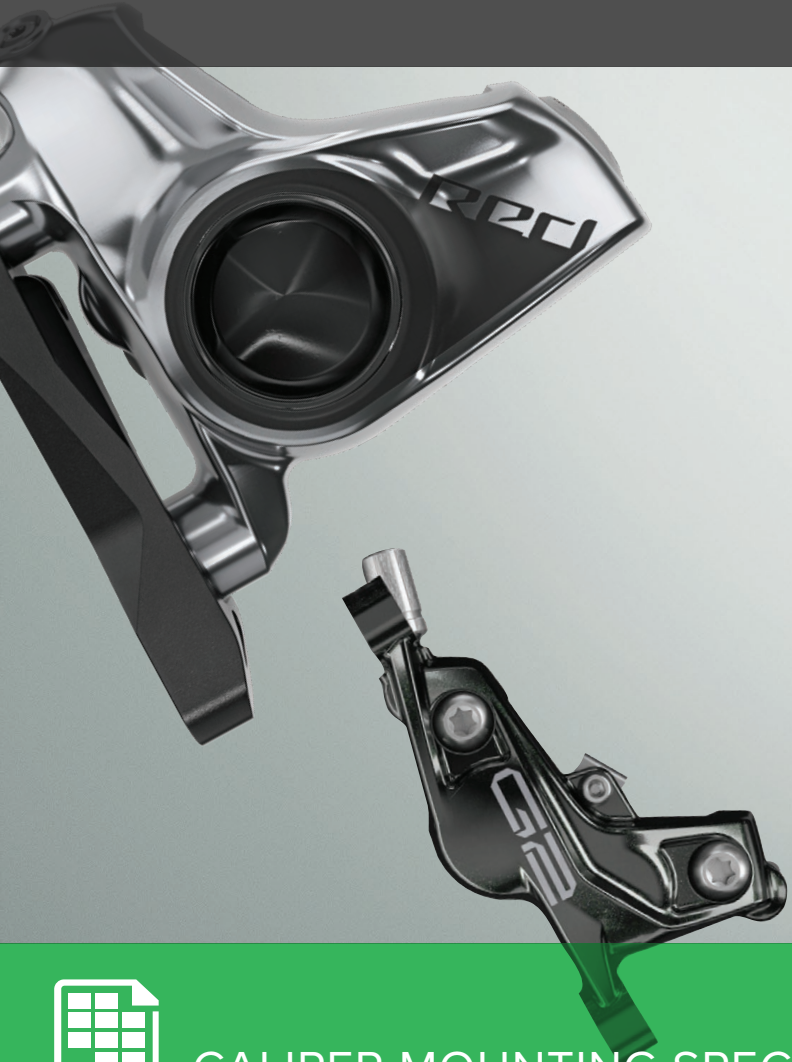

CALIPER MOUNTING SPECIFICATIONS

Table of Contents

Bolt Length Specification	3
Recommended Road Rotor Size and Brake Pad Material	4
SRAM Caliper Type Identification	5
Fork Mount Identification.....	6
Frame Mount Identification	7
Flat Mount and Thru Bolt Standard	8
Flat Mount and Thru Bolt Standard	9
Post Mount Standard	10
Post Mount Standard	11
Post Mount Standard	12
Post Mount Standard with CPS Washers.....	13
Post Mount Standard	14
International Standard Mount (IS)	15
IS Standard	16

Bolt Length Specification

Bolts and brackets may need to be purchased separately.

⚠ WARNING

Choose the correct bolt length for proper thread engagement. Riding a bike with improper bolt engagement can allow the brakes to disengage from the bicycle, which can lead to a crash and serious injury or death to the rider.

For forks and frames with thru bolt or flat mounts, with or without brackets, there must be 5-7 mm of mounting bolt thread engagement when mounting brake calipers.

For forks and frames with post mounts, with or without brackets and/or spacers, there must be 9-13 mm of mounting bolt thread engagement when mounting brake calipers.

Flat Mount Frame and Thru Bolt Fork

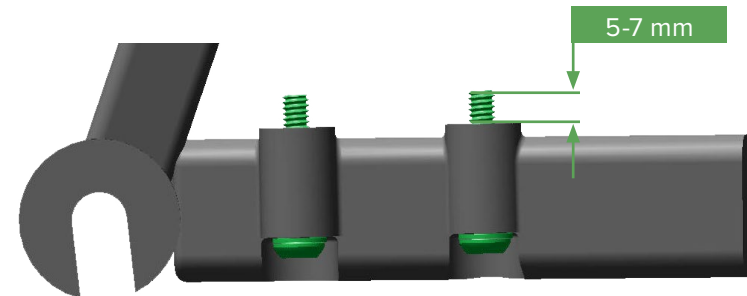

Post Mount Fork

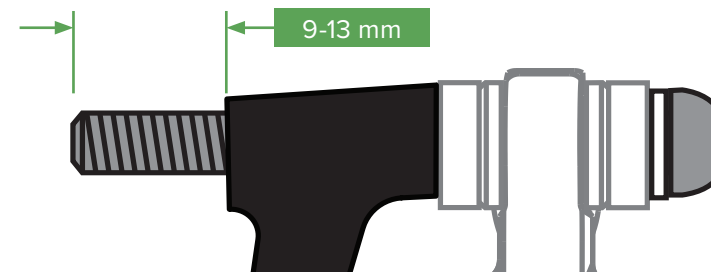

Recommended Road Rotor Size and Brake Pad Material

All SRAM Road Hydraulic Brakes

		Riding Style		
		Cyclocross / Time Trial	Road / Gravel- General	Road / Gravel- Alpine
		Organic or Sintered	Organic	Organic
System Weight ¹	< 140 lbs (63 kg)	ø140 mm ³	ø140 mm ³	ø140 mm ³
	140 - 160 lbs (63 - 73 kg)			ø140 mm / ø160 mm ²
	160 - 180 lbs (73 - 82 kg)	ø140 mm / ø160 mm ²	ø160 mm	ø160 mm
	180 - 200 lbs (82 - 91 kg)			
	200 - 240 lbs (91 - 109 kg)	ø160 mm	ø160 mm / ø180 mm ²	ø180 mm ³
	240-260 lbs (109-118 kg)	ø160 mm / ø180 mm ²		
	260-280 lbs (118-127 kg)	ø180 mm ³	ø180 mm ³	ø180 mm ³

¹ System weight includes the total weight of the bicycle, rider, and all the additional attached items.

² øX / øY show the recommended rotor size for rear and front use.

³ Consult the fork or frame manufacturer's specification before using a ø140 or a ø180 mm rotor. These rotor sizes have compatibility limitations on many frames and forks.

SRAM Caliper Type Identification

Flat Mount

Flat Tab

The caliper has flat tabs and may need a bracket to attach to the frame or fork.



Post Mount

Offset Tab

No CPS washers are needed between the caliper and mount (unless otherwise specified).

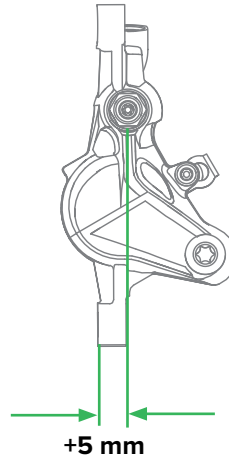

Post Mount- Caliper Positioning System (CPS)

Inline Tab

CPS washers are needed between the caliper and mount (unless otherwise specified).

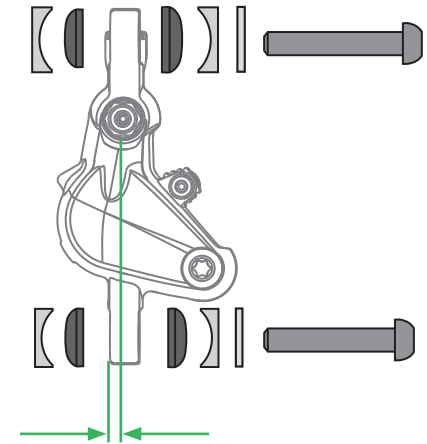

Fork Mount Identification

Consult the fork manufacturer's instructions, or measure the distance between the center of each bolt hole, to identify the fork mount.

Flat mount is 70 mm.

Post mount is 74 mm.

Thru bolt fork is 34 mm, and have bolt holes that go through the fork leg.

IS mount is 51 mm.

Flat Mount Fork

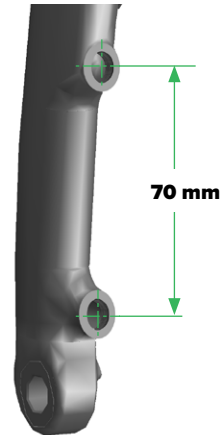

Post Mount Fork

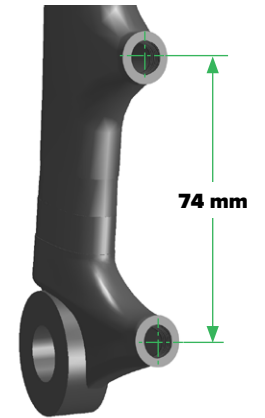

Thru Bolt Fork

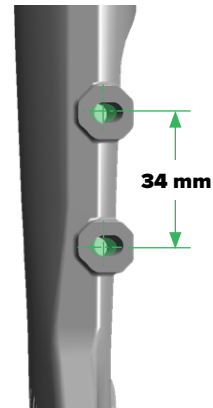

IS Mount Fork

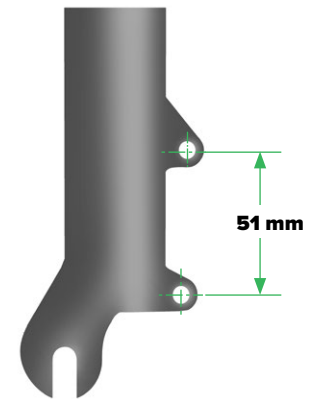

Frame Mount Identification

Consult the frame manufacturer's instructions, or measure the distance between the center of each bolt hole, to identify the frame mount.

Flat mount is 34 mm.

Post mount is 74 mm.

IS mount is 51 mm.

Flat Mount Frame

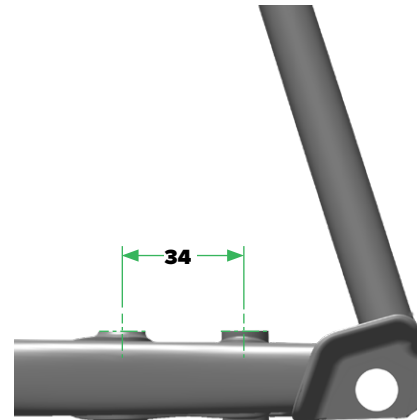

Post Mount Frame

Chainstay Mount

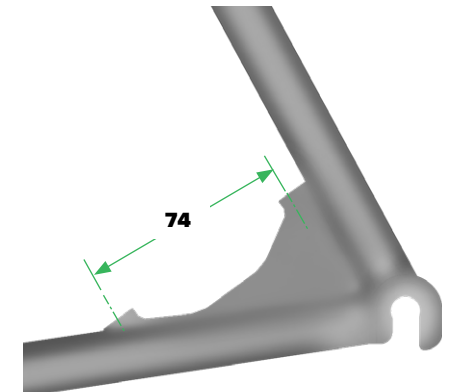

IS Mount Frame

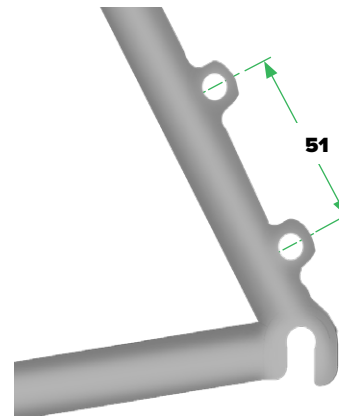

Seatstay Mount

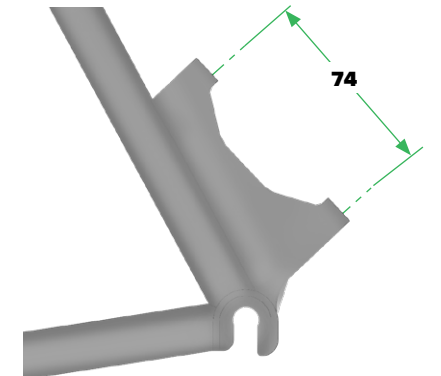

Flat Mount and Thru Bolt Standard

Rotor and Mounting Configurations

Identify your frame or fork's mounting standard and the recommended rotor size, then use the chart to determine the appropriate mounting and hardware configuration.

Measure

Flat Mount and Thru Bolt Fork

Measure from the centerline of the bottom slot to the centerline of the axle.

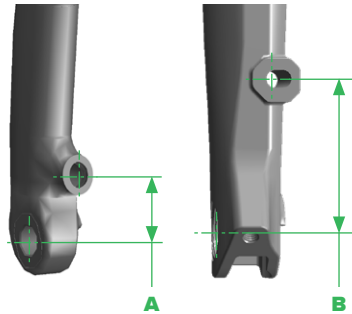

Rear

Measure from the centerline of the bottom slot to the centerline of the axle.

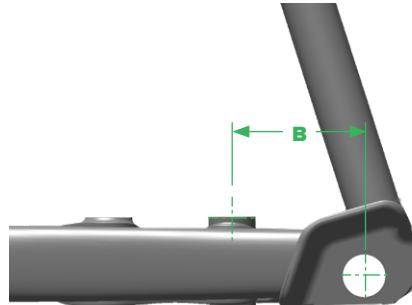

Hardware

Use the charts on the following page to install the correct hardware.

	Flat Head Bolt
	Washer
	Button Head Bolt

Brackets

Front Flat Mount Bracket F0/F20*

Position the Front Flat Mount Bracket to the 0 mm or the +20 mm orientation, according to the chart.

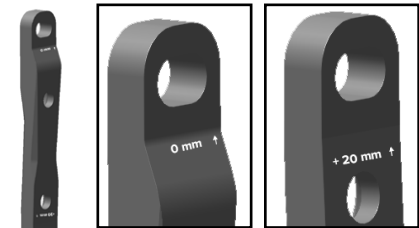

*Some flat mount brackets have 140 mm printed on the bracket for 0 mm, and 160 mm printed on the bracket for +20 mm.

Rear Bracket F20

Position the Rear Bracket F20 onto the frame or the Thru Bolt, according to the chart.



		Rotor Size			
		140 mm	160 mm	180 mm	
Fork / Frame	Dimension A	23.5 mm	Front Flat Mount Bracket F0 position	Front Flat Mount Bracket F20 position	-
		32 mm	-	Front Flat Mount Bracket F0 position	Front Flat Mount Bracket F20 position
	Dimension B	36.5 mm	Direct to frame or thru bolt fork	Rear Bracket F20	-
		45 mm	-	Direct to frame or thru bolt fork	Rear Bracket F20

Flat Mount and Thru Bolt Standard

Flat Mount Caliper Configurations

MTB

Level Ultimate
Level TLM

Front Bracket - F0

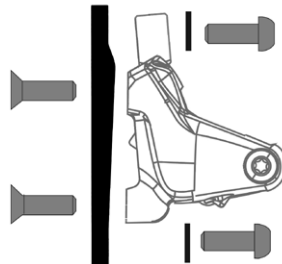

Front / Rear Direct Mount - FDO

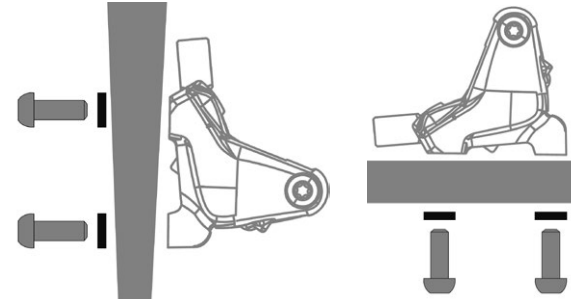

Frame or Fork Boss Thickness	Button Head Bolts
10 mm	17 mm
15 mm	22 mm
20 mm	27 mm
25 mm	32 mm
30 mm	37 mm
35 mm	42 mm

Road

SRAM RED eTap AXS HRD
SRAM FORCE eTap AXS HRD
SRAM RIVAL eTap AXS HRD
SRAM RED eTap HRD
SRAM RED HRD
SRAM FORCE HRD
SRAM RIVAL HRD
SRAM APEX HRD
S-900 Aero HRD

Front Bracket - F20

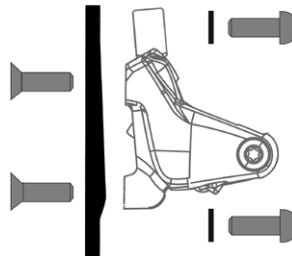

Front / Rear 20 mm Bracket - FD20

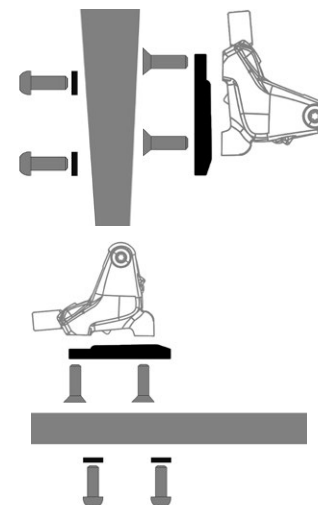

Frame or Fork Boss Thickness	Button Head Bolts	Flat Head Bolts
10 mm	17 mm	10.7 mm
15 mm	22 mm	10.7 mm
20 mm	27 mm	10.7 mm
25 mm	32 mm	10.7 mm
30 mm	37 mm	10.7 mm
35 mm	42 mm	10.7 mm

Upper Button Head Bolt	Lower Button Head Bolt	Flat Head Bolt	Flat Head Bolt
15 mm	15 mm	10.7 mm	10.7 mm

Upper Button Head Bolt	Lower Button Head Bolt	Flat Head Bolt	Flat Head Bolt
15 mm	15 mm	10.7 mm	10.7 mm

*see chart on page 8

Post Mount Standard

Rotor and Mounting Configurations for an Offset Tab Caliper

Identify your frame or fork's mounting standard and your preferred rotor size, then use the chart to determine the appropriate mounting configuration with an offset tab caliper.

Offset Tab

Calipers with an Offset Tab do **not** need CPS washers between the caliper and mount, unless otherwise specified.

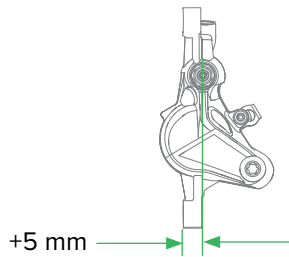

Direct Mount (Direct)

No post bracket or spacer(s) are needed to attach the caliper to the frame or fork.

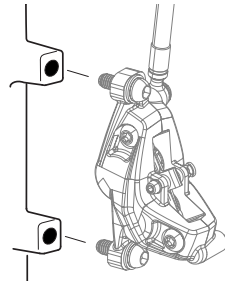

Post Spacer (S)

Some rotor sizes require the use of spacer(s) to fit the caliper to the frame or fork.



Post Bracket (P)**

Some rotor sizes require the use of a post bracket to fit the caliper to the frame or fork.



		Rotor Size							
		140 mm	160 mm	170 mm	180 mm	185 mm	200 mm	203 mm	220 mm*
Fork / Frame	140 Post	Direct	20 S 20 P-1	30 P	40 P	-	-	-	-
	160 Post	-	Direct	10 S	20 S 20 P-1	25 S	40 P	-	-
	180 Post	-	-	-	Direct	-	20 S 20 P-2	-	40 P
	200 Post	-	-	-	-	-	Direct	3 S	20 S 20 P-2
	203 Post	-	-	-	-	-	-	Direct	17 P**

* The 220 mm diameter rotor is designed for use with a 4-piston caliper.

** The 17P Post Bracket must be used with a 203 Post Fork or Frame that meets the SRAM Disc Brake Post Mount Specification in the *SRAM MTB Frame Fit Specifications* on www.sram.com/service.

Post Mount Standard

Offset Tab Caliper Configurations

MTB

G2
Guide
Level
DB
XX
X0
CODE 2017+
Elixir 2013+
Maven*

Road

SRAM RED eTap AXS HRD
SRAM RED eTap HRD
SRAM RED HRD
SRAM FORCE HRD
SRAM RIVAL HRD
SRAM APEX HRD
SRAM S-700

Direct*

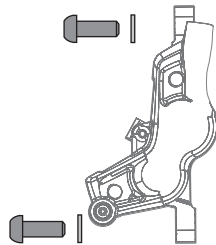

Upper Bolt		Lower Bolt	
18 mm		18 mm	

10 S

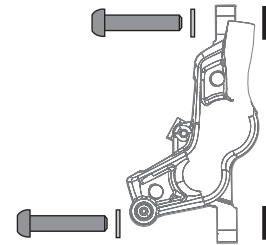

Upper Bolt	Upper Spacer	Lower Bolt	Lower Spacer
24 mm	6 mm	24 mm	6 mm

17 P

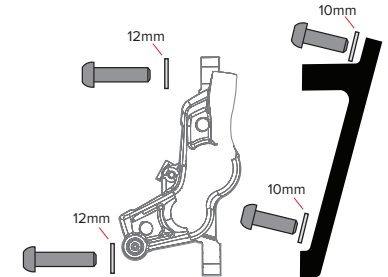

Upper Bolt	Bracket Bolt	Lower Bolt	Bracket Bolt
18 mm	18 mm	18 mm	18 mm

3 S

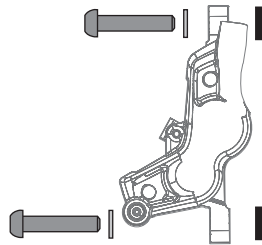

Upper Bolt	Upper Spacer	Lower Bolt	Lower Spacer
20 mm	1.5 mm	20 mm	1.5 mm

20 S

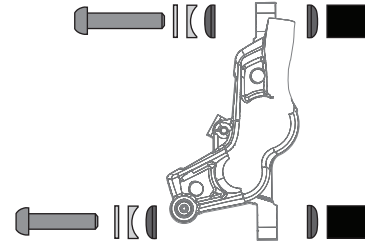

Upper Bolt	Upper Spacer	Lower Bolt	Lower Spacer
39.5 mm	12.5 mm	34 mm	7.5 mm

20 P (Pre-2024)

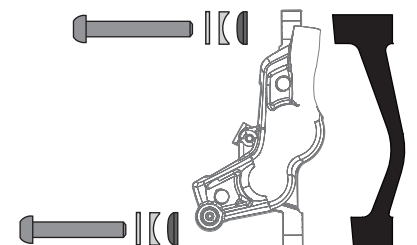

Upper Bolt		Lower Bolt	
39.5 mm		34 mm	

Post Mount Standard

Offset Tab Caliper Configurations

MTB

G2
Guide
Level
DB
XX
X0
CODE 2017+
Elixir 2013+
Maven

20 P-1

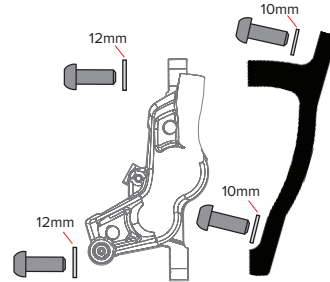

20 P-2

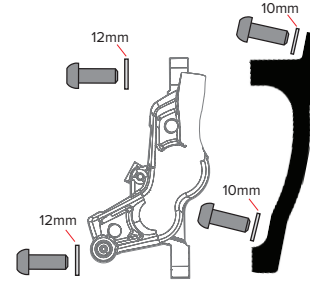

Road

SRAM RED eTap AXS HRD
SRAM RED eTap HRD
SRAM RED HRD
SRAM FORCE HRD
SRAM RIVAL HRD
SRAM APEX HRD
SRAM S-700

Upper Bolt	Bracket Bolt	Lower Bolt	Bracket Bolt
18 mm	18 mm	18 mm	18 mm

Upper Bolt	Bracket Bolt	Lower Bolt	Bracket Bolt
18 mm	18 mm	18 mm	18 mm

30 P

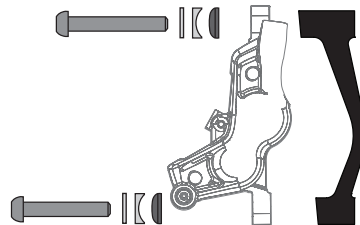

Upper Bolt		Lower Bolt	
46 mm		39.5 mm	

40 P

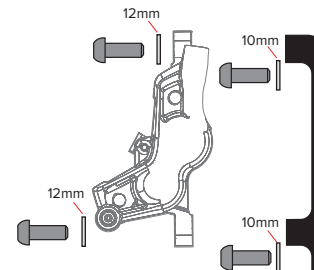

Upper Bolt	Bracket Bolt	Lower Bolt	Bracket Bolt
18 mm	18 mm	18 mm	18 mm

Post Mount Standard with CPS Washers

Rotor and Mounting Configurations for Inline Tab Caliper



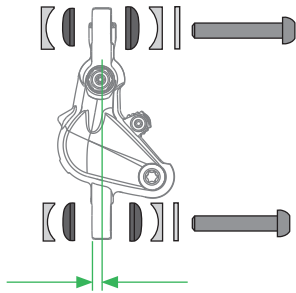

Identify your frame or fork's mounting standard and your preferred rotor size, then use the chart to determine the appropriate mounting configuration to use with an Inline Tab caliper.

Inline Tab

An Inline tab caliper needs CPS washers between the caliper and mount, unless otherwise specified.



Hardware

	Convex Washer
	Concave Washer
	Washer
	Button Head Bolt

Rotor Size

Fork / Frame	Rotor Size							
	140 mm	160 mm	170 mm	180 mm	185 mm	200 mm	203 mm	220 mm*
140 Post	Direct	20 S 20 P	30 P	40 P	-	-	-	-
160 Post	-	Direct	10 S	20 S 20 P	25 S	40 P	-	-
180 Post	-	-	-	Direct	-	20 S 20 P	-	40 P
200 Post	-	-	-	-	-	Direct	3 S	20 S 20 P
203 Post	-	-	-	-	-	-	Direct	17 P

* The 220 mm diameter rotor is designed for use with a 4-piston caliper.

Post Mount Standard

Inline Tab CPS Caliper Configurations

MTB

Guide RE
 CODE Pre-2017
 CODE R Pre-2017
 Elixir Pre-2013
 Juicy
 BB7
 BB5
 BB3

Direct

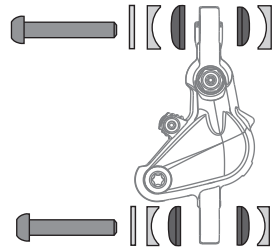

20 S

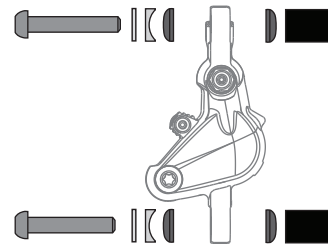

25 S

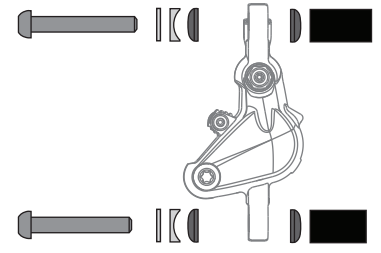

Road

BB7 Road
 BB5 Road

Upper Bolt		Lower Bolt	
29 mm		29 mm	

Upper Bolt	Upper Spacer	Lower Bolt	Lower Spacer
44 mm	17.5 mm	39.5 mm	12.5 mm

Upper Bolt	Upper Spacer	Lower Bolt	Lower Spacer
46 mm	20.5 mm	40.5 mm	15 mm

10 S

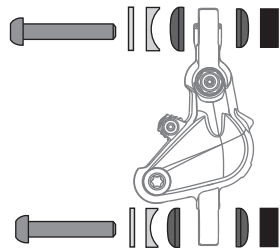

Upper Bolt	Upper Spacer	Lower Bolt	Lower Spacer
39.5 mm	12.5 mm	34 mm	7.5 mm

20 P

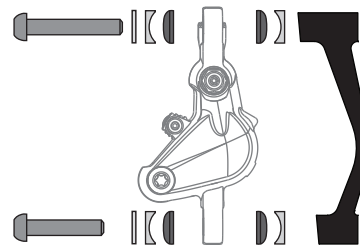

Upper Bolt		Lower Bolt	
44 mm		39.5 mm	

30 P

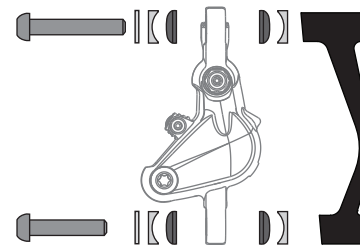

Upper Bolt		Lower Bolt	
50 mm		44 mm	

40 P

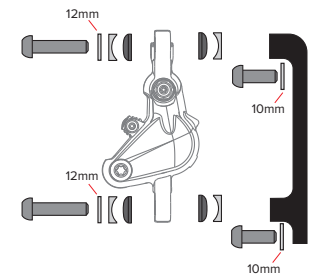

Upper Bolt	Bracket Bolt	Lower Bolt	Bracket Bolt
29 mm	18 mm	29 mm	18 mm

International Standard Mount (IS)

Rotor and Mounting Configurations

Identify your frame or fork's mounting standard and your preferred rotor size, then use the chart to determine the appropriate mounting configuration.

IS Bracket

To use a Post Mount caliper or a CPS Caliper on a IS frame or fork, you must use an IS bracket.

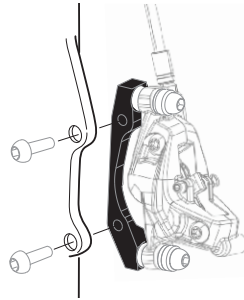

		Rotor Size							
		140 mm	160 mm	170 mm	180 mm	185 mm	200 mm	203 mm	220 mm*
Fork / Frame	140 IS	0 IS	20 IS	30 IS	40 IS	45 IS	60 IS	-	-
	160 IS	-	0 IS	-	20 IS	25 IS	40 IS	-	60 IS

* The 220 mm diameter rotor is designed for use with a 4-piston caliper.

IS Standard

Offset Tab and Inline Tab Caliper Configurations

MTB

G2
Guide
Level
DB
XX
X0
CODE 2017+
Elixir 2013+

IS to Post Mount Caliper

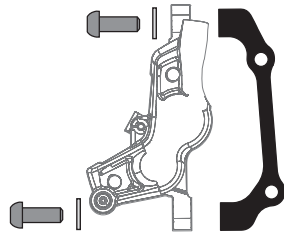

Upper Bolt		Lower Bolt	
18 mm		18 mm	

IS to CPS Caliper

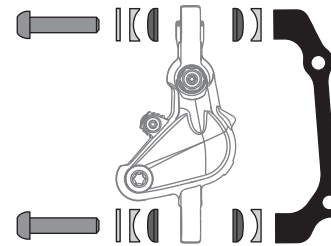

Upper Bolt		Lower Bolt	
29 mm		29 mm	

Road

SRAM RED eTap AXS HRD
SRAM RED eTap HRD
SRAM RED HRD
SRAM FORCE HRD
SRAM RIVAL HRD
SRAM APEX HRD
SRAM S-700

ASIAN HEADQUARTERS

SRAM Taiwan
No. 1598-8 Chung Shan Road
Shen Kang Hsiang, Taichung City
Taiwan

WORLD HEADQUARTERS

SRAM, LLC
1000 W. Fulton Market, 4th Floor
Chicago, Illinois 60607
U.S.A.

EUROPEAN HEADQUARTERS

SRAM Europe
Paasbosweg 14-16
3862ZS Nijkerk
The Netherlands