

2023 MTB Components

XX1 X01 GX NX

XX1 XX X01 X0 EX1 X1

GX NX SX X9 X7 X5

LEVEL GUIDE GR



FRAME FIT SPECIFICATIONS

General Notes

All dimensions are in millimeters unless otherwise noted.

Images in this document are not to scale.

Your product's appearance may vary slightly from the images in this document.

Information in this document is subject to change without prior notice.

If you have any questions please contact your SRAM representative.

Table of Contents

Rear Derailleurs

Universal Derailleur Hanger Specifications	8
Hanger Specifications	9
Hanger Thickness	10
Chainstay Length/Rear Derailleur Mounting Clearance	11
Rear Derailleur Frame Clearance	12
Chain/Cassette Frame Clearance	13
Hanger Straightness	14
Cable Routing	
Cable Housing Stop and AXS Extension Cord Dimensions	15

Cranksets

Q-Factor	
Measurement Information	17
Crank Boot	
Clearance Information	18

DUB Cranks

XX1 Eagle DUB

XX1 Eagle DUB	
Drive Side Frame Clearance - BOOST and non-BOOST	21
Non-Drive Frame Clearance	22
XX1 Eagle DUB Power Meter	
Drive Side Frame Clearance*	23
Non-Drive Frame Clearance	24

XX1 Eagle DUB - Fatbike

Drive Side Frame Clearance	25
Non-Drive Frame Clearance	26

X01 Eagle DUB

X01 Eagle DUB

Drive Side Frame Clearance - BOOST and non-BOOST	28
Non-Drive Frame Clearance	29

X01 Eagle DUB SB+

Drive Side Frame Clearance	30
Non-Drive Frame Clearance	31

X01 Eagle DUB - Fatbike

Drive Side Frame Clearance	32
Non-Drive Frame Clearance	33

X01 DH

X01 EAGLE DH DUB73

Drive Side Frame Clearance - BOOST and non-BOOST	35
Non-Drive Frame Clearance	36

X01 DH DUB

Drive Side Frame Clearance	37
Non-Drive Frame Clearance	38

X01 DH DUB73

Drive Side Frame Clearance	39
Non-Drive Frame Clearance	40

X1 Carbon Eagle DUB/Descendant Carbon Eagle DUB/Stylo Carbon Eagle DUB

X1 Carbon Eagle DUB/Descendant Carbon Eagle DUB/Stylo Carbon Eagle DUB

Drive Side Frame Clearance - BOOST and non-BOOST	42
Non-Drive Frame Clearance	43

X1 Carbon Eagle DUB/Descendant Carbon Eagle DUB/Stylo Carbon Eagle DUB - Fatbike

Drive Side Frame Clearance - BOOST and non-BOOST	44
Non-Drive Frame Clearance	45

GX Eagle DUB

GX Eagle DUB

Drive Side Frame Clearance - BOOST and non-BOOST	47
Non-Drive Frame Clearance	48

GX Eagle DUB SB+

Drive Side Frame Clearance	49
Non-Drive Frame Clearance	50

GX Eagle DUB - Fatbike

Drive Side Frame Clearance	51
Non-Drive Frame Clearance	52

Descendant 7K Eagle DUB

Descendant 7K Eagle DUB

Drive Side Frame Clearance - BOOST and non-BOOST	54
Non-Drive Frame Clearance	55

Descendant Eagle DUB SB+

Drive Side Frame Clearance	56
Non-Drive Frame Clearance	57

Descendant 6K Eagle DUB

Descendant 6K Eagle DUB

Drive Side Frame Clearance - BOOST and non-BOOST	59
Non-Drive Frame Clearance	60

Descendant DH DUB

Descendant DH DUB

Drive Side Frame Clearance	62
Non-Drive Frame Clearance	63

NX Eagle DUB/Stylo 7K Eagle DUB

NX Eagle DUB/Stylo 7K Eagle DUB

Drive Side Frame Clearance - BOOST and non-BOOST	65
Non-Drive Frame Clearance	66

NX Eagle DUB/Stylo 7K Eagle DUB - Fat 4

Drive Side Frame Clearance	67
Non-Drive Frame Clearance	68

NX Eagle DUB/Stylo 6K Eagle DUB

NX Eagle DUB/Stylo 6K Eagle DUB

Drive Side Frame Clearance	70
Non-Drive Frame Clearance	71

NX Eagle DUB/Stylo 6K Eagle DUB - Fat 4

Drive Side Frame Clearance	72
Non-Drive Frame Clearance	73

NX Eagle DUB - Fat 5

Drive Side Frame Clearance	74
Non-Drive Frame Clearance	75

SX Eagle DUB/X1-1000 DUB

SX Eagle DUB/X1-1000 DUB

Drive Side Frame Clearance - BOOST and non-BOOST	77
Non-Drive Frame Clearance	78

X1 1000 Eagle DUB Fat 5

X1 1000 Eagle DUB Fat 5

Drive Side Frame Clearance	80
Non-Drive Frame Clearance	81

1x11 & 1x7 Cranksets

NX

Crankset Frame Clearance	83
--------------------------------	----

NX - BOOST 148 Compatible

Crankset Frame Clearance	84
--------------------------------	----

NX Power Spline

Crankset Frame Clearance	85
--------------------------------	----

NX Power Spline - BOOST 148 Compatible

Crankset Frame Clearance	86
--------------------------------	----

NX - Fatbike

Crankset Frame Clearance	87
--------------------------------	----

2x10 Cranksets

GX-1200

Crankset Frame Clearance	89
--------------------------------	----

GX-1000/X5

Crankset Frame Clearance	90
--------------------------------	----

GX-1000 - BOOST 148 Compatible

Crankset Frame Clearance	91
--------------------------------	----

GX-1000/X5 - Fatbike

Crankset Frame Clearance	92
--------------------------------	----

3x10 Cranksets

X5

Crankset Frame Clearance	94
--------------------------------	----

E-MTB Cranksets

S800E/X1-1000E/EX1 - BOSCH - Compatible

Crankset Frame Clearance	96
--------------------------------	----

104 BCD Steel Chainring Spider Requirements..... 97

Bottom Bracket Shell Specifications

BSA 68/73/83/100

Bottom Bracket Shell Specifications	99
---	----

PressFit

Bottom Bracket Shell Specification	101
--	-----

BB30

Information.....	102
------------------	-----

DUB Bottom Brackets

DUB BSA 68/73/83

Bottom Bracket Specification.....	104
-----------------------------------	-----

DUB BSA 100

Bottom Bracket Specification.....	105
-----------------------------------	-----

DUB PressFit MTB

Bottom Bracket Specification.....	106
-----------------------------------	-----

DUB PressFit 30

Bottom Bracket Specification.....	107
-----------------------------------	-----

DUB BB30

Bottom Bracket Specification.....	108
-----------------------------------	-----

PressFit GXP 89.5/92

Bottom Bracket Specification.....	109
-----------------------------------	-----

PressFit GXP 104.5 DH/107 DH	
Bottom Bracket Specification.....	110
PressFit GXP 121 Fatbike	
Bottom Bracket Specification.....	111
PressFit 30	
Bottom Bracket Specification.....	112

Wheels & Hubs

Splined MTB Driver Body Specifications	114
Maxle Description Decoder.....	116
Maxle Ultimate	
Frame/Fork Clearance	117
Maxle Stealth	118
Maxle Lite & Maxle	
Frame/Fork Clearance	119
Maxle, Maxle Lite, Maxle Ultimate, Maxle Stealth	
Rear Frame Specification	120
Maxle, Maxle Lite, Maxle Ultimate, Maxle Stealth	
Fork Specification.....	121
Maxle, Maxle Lite, Maxle Ultimate, Maxle Stealth	
Fork Specification.....	122

Brakes

SRAM MTB Hydraulic Disc Brakes	
Safety Guidelines for Rotor Size and Brake Pad Material.....	125
Flat Mount, Post Mount, and International Standard Mount....	126
International Standard Fork Mount.....	128
BB7/ BB5	
Mechanical Disc Brake Clearance	133
Mechanical Brake Specifications	
Rear International Standard and Post Fork Mount	134
Brake Boss Dimensions.....	135
Shorty Ultimate.....	136

Handlebar Specification.....	137
-------------------------------------	------------

Rotors

HS2	
6-Bolt Rotor Dimensions.....	139
HS2	
One-Piece Center Locking Rotor Dimensions.....	140
CenterLine X	
Two-Piece 6-Bolt Rotor Dimensions	141
CenterLine X	
Two-Piece Center Locking Rotor Dimensions	142
CenterLine XR	
Two-piece 6-Bolt Rotor Dimensions.....	143
CenterLine XR	
Two-piece Center Locking Rotor Dimensions	144
CenterLine	
6-Bolt Rotor Dimensions.....	145
CenterLine	
One-Piece Center Locking Rotor Dimensions.....	146
Lockring for Center Locking Rotor	
Specifications	147
Spoke Clearance.....	148

Rear Derailleurs

All SRAM rear derailleurs are compatible with all existing axle standards and hub widths, if the following specifications are respected.

Universal Derailleur Hanger Specifications

Please visit www.UniversalDerailleurHanger.com for complete specifications.

Hanger Specifications

Rear Derailleur Hanger Specifications

L	X	A	R1	R2	R3
Hanger material hardness: HRB > 86					
30-34	6.5-9.5	25°-30°	8-8.5	12.5-14.5	max. 0.5

For any dimension outside of these specs, depending on the combination of all the variables, the performance of the drivetrain may be compromised. Please contact your account manager for further technical information.

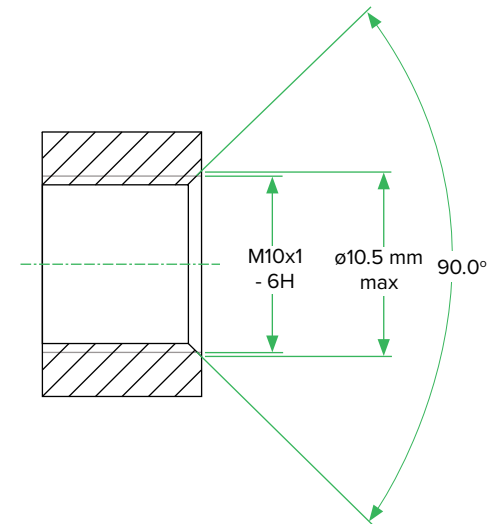
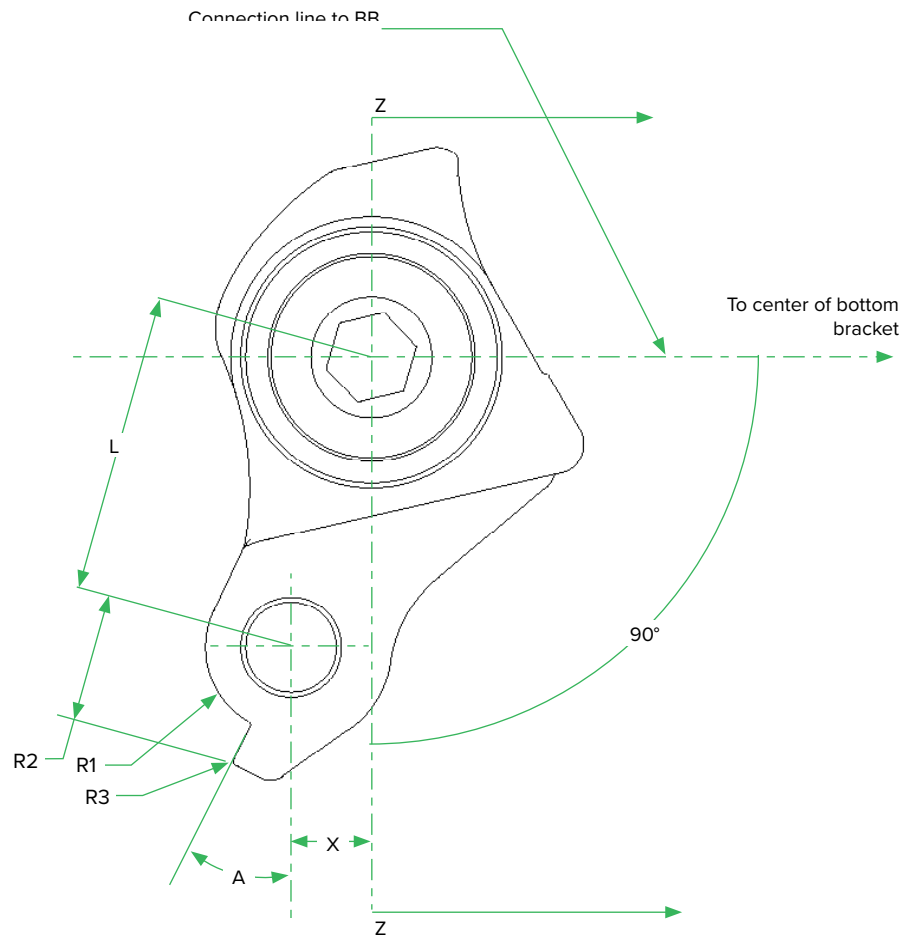

Hanger Thickness

	T (mm)
Quick Release	8-9
Thru Axle	4.5-5.5 (3.5mm frame slot)

For any dimension outside of these specs, depending on the combination of all the variables, the performance of the drivetrain may be compromised. Please contact your account manager for further technical information.

Quick Release

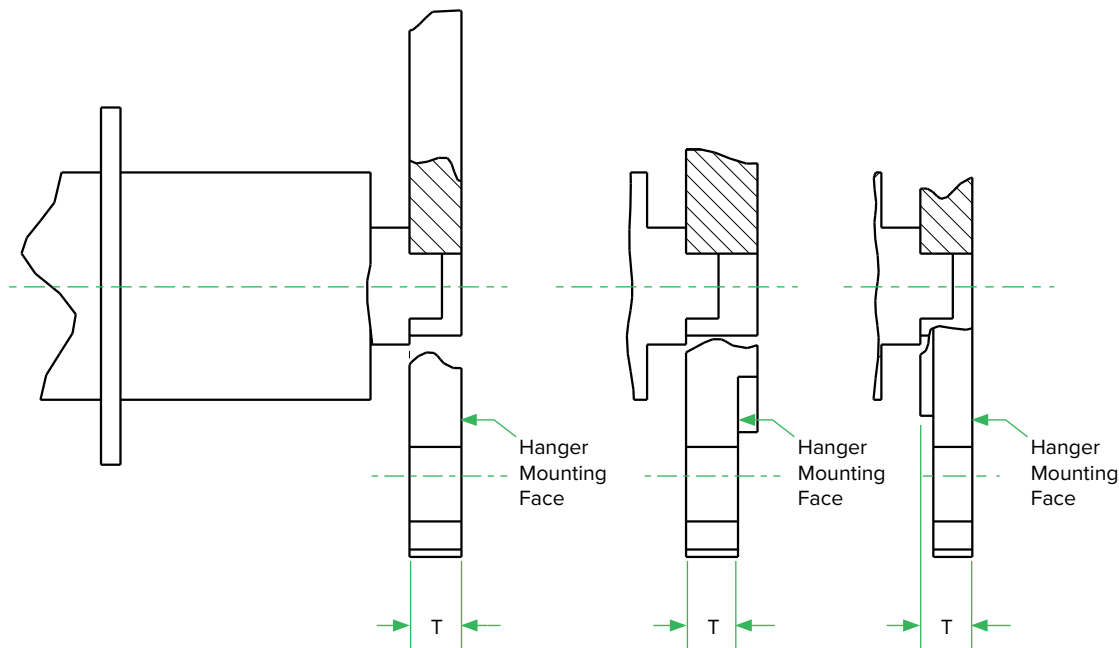

Thru Axle

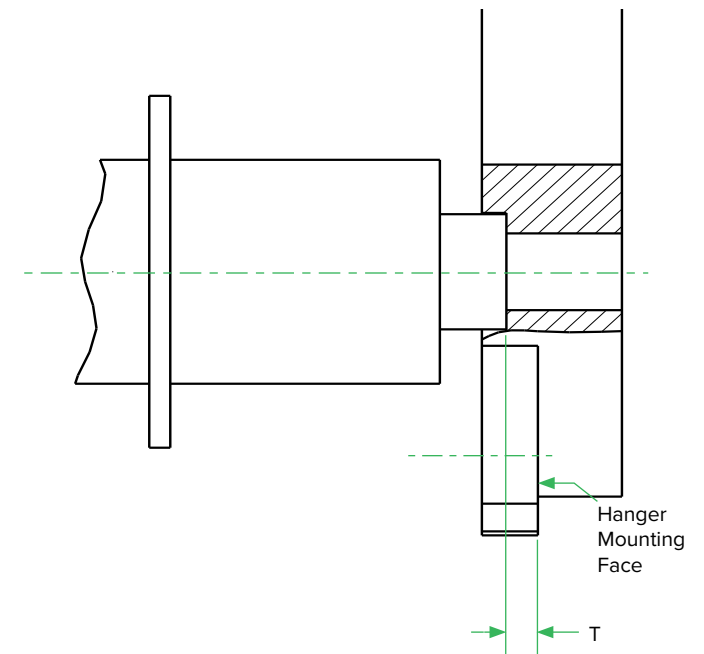

Chainstay Length/Rear Derailleur Mounting Clearance

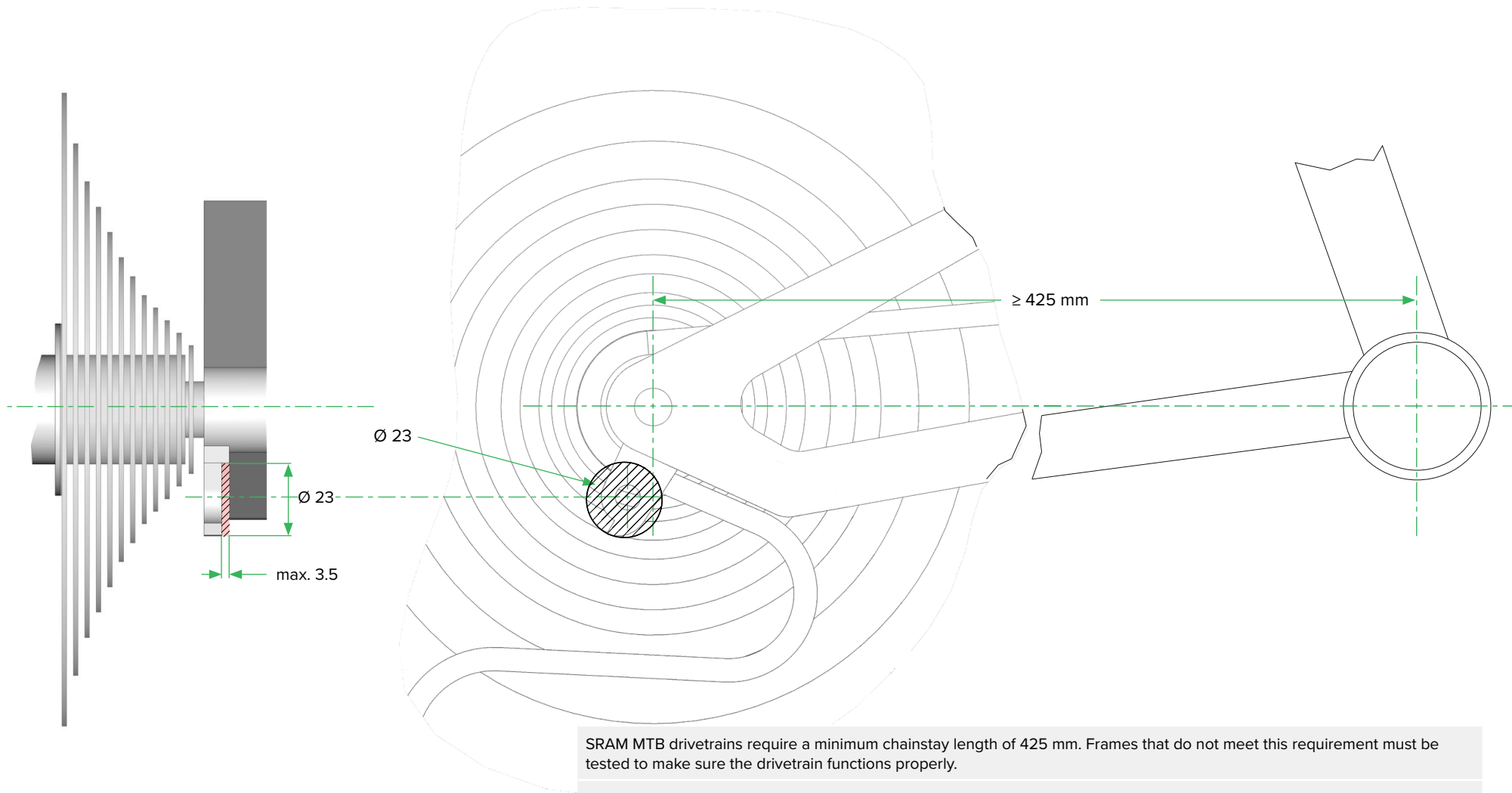

SRAM MTB drivetrains require a minimum chainstay length of 425 mm. Frames that do not meet this requirement must be tested to make sure the drivetrain functions properly.

Chainstay growth must not exceed 27 mm.

Rear Derailleur Frame Clearance

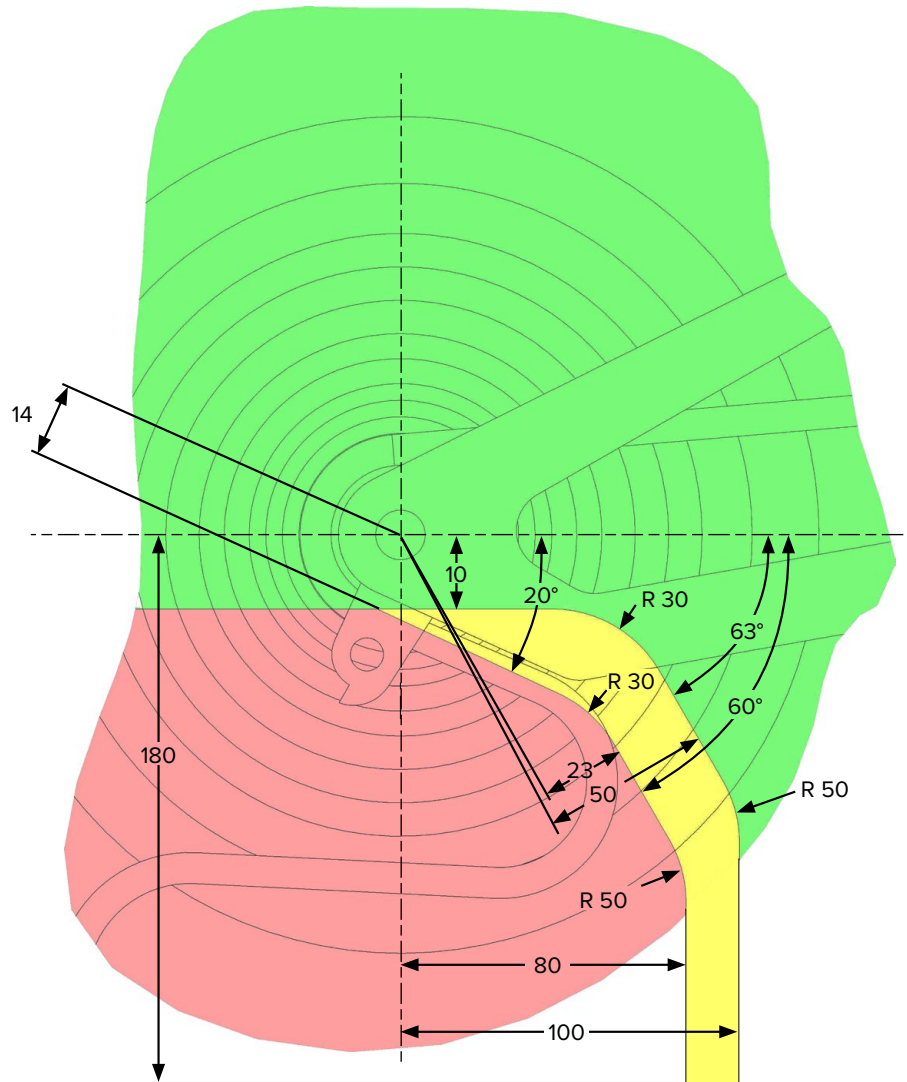

Correct chain gap adjustment is likely impossible if a chainstay or linkage element interferes with the red zone. Correct adjustment may or may not be possible depending on the combination of variables if there is chainstay or linkage interference within the yellow zone.

Chain/Cassette Frame Clearance

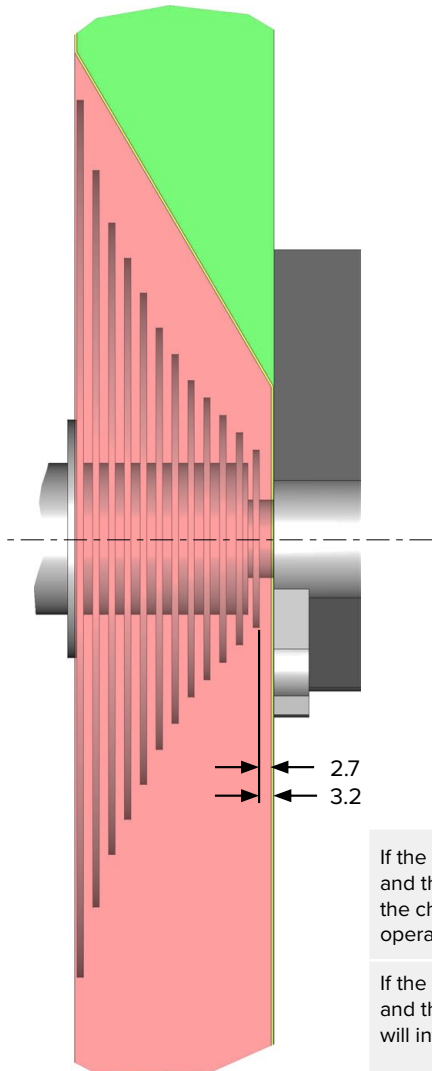

If the gap between the outer edge of the smallest cog and the frame inside plane is between 2.7 and 3.2 mm, the chain may contact the frame slightly during shift operation.

If the gap between the outer edge of the smallest cog and the derailleur hanger is less than 2.7 mm, the chain will interfere with the frame during shift operation.

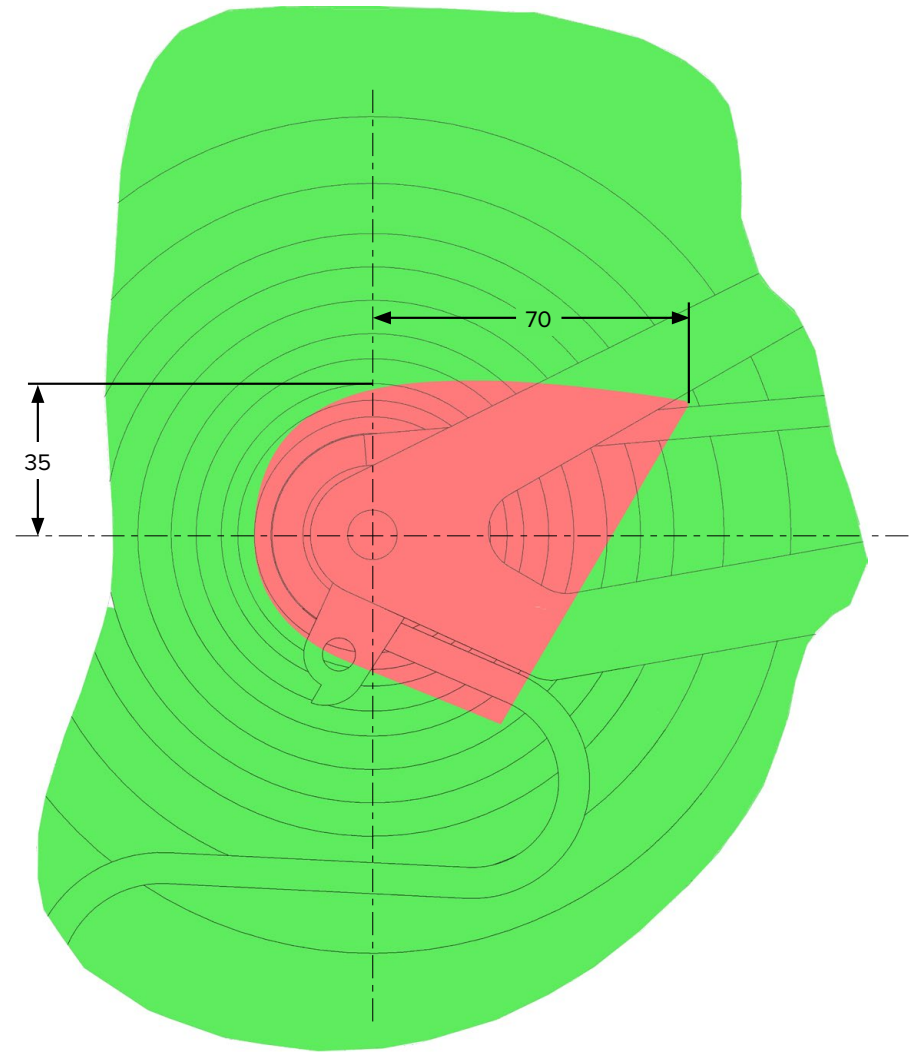

Hanger Straightness

The rear derailleur hanger alignment has to be checked in relation to the rear hub axis. The entire circumference of the rim must be checked with a hanger alignment tool. The difference between "A max" and "A min" should be smaller than 5 mm. The rim must be perfectly true. If the rim is not true it must be turned with the tool for inspection.

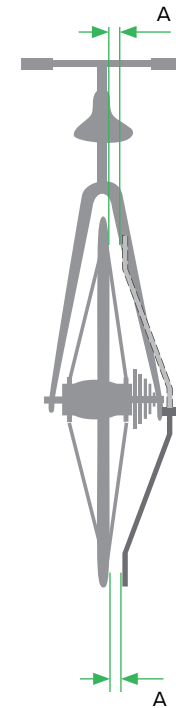
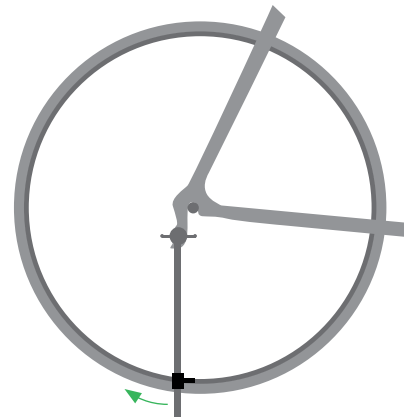
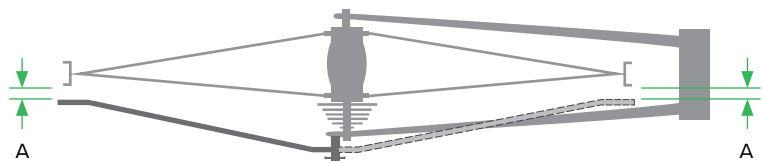

Cable Routing

Cable Housing Stop and AXS Extension Cord Dimensions

Use dedicated derailleur cables and housings with compressionless housing, low friction liner, aluminum ferrules without sealing, and 1.1 mm polished cable.

Ferrule diameter 5.7+0.1 mm. Continuous housing only.

Maximum total bend angle of 500°. Minimum bend radius of 50 mm.

Avoid : S-bends with small radii and pinch spots (high housing clamping force).

Exit at the rear end best at seat stay or on top of the chain stay.

Minimize cable bending due to suspension and handlebar motion

AXS Extension Cord			
MAX Length Connector D	MAX Diameter Connector E	MIN Bending Radius F	MAX Cable Diameter G
19	Ø 5.8	8.4	Ø 4

For compatibility with the AXS Extension Cord, a cyclinder diameter (diameter E and length D), must pass through the designated internal cable routing path of the frame.

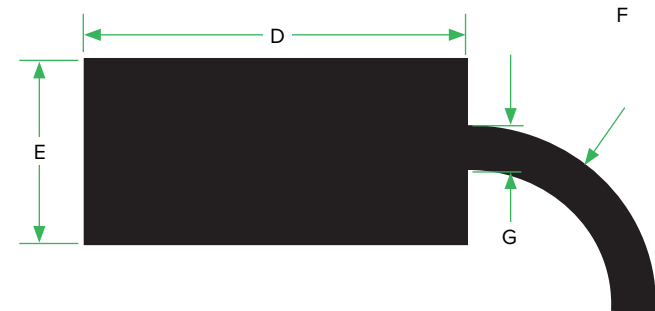

Cranksets

Q-Factor

Measurement Information

Q-Factor is the distance between the two pedal spot faces.

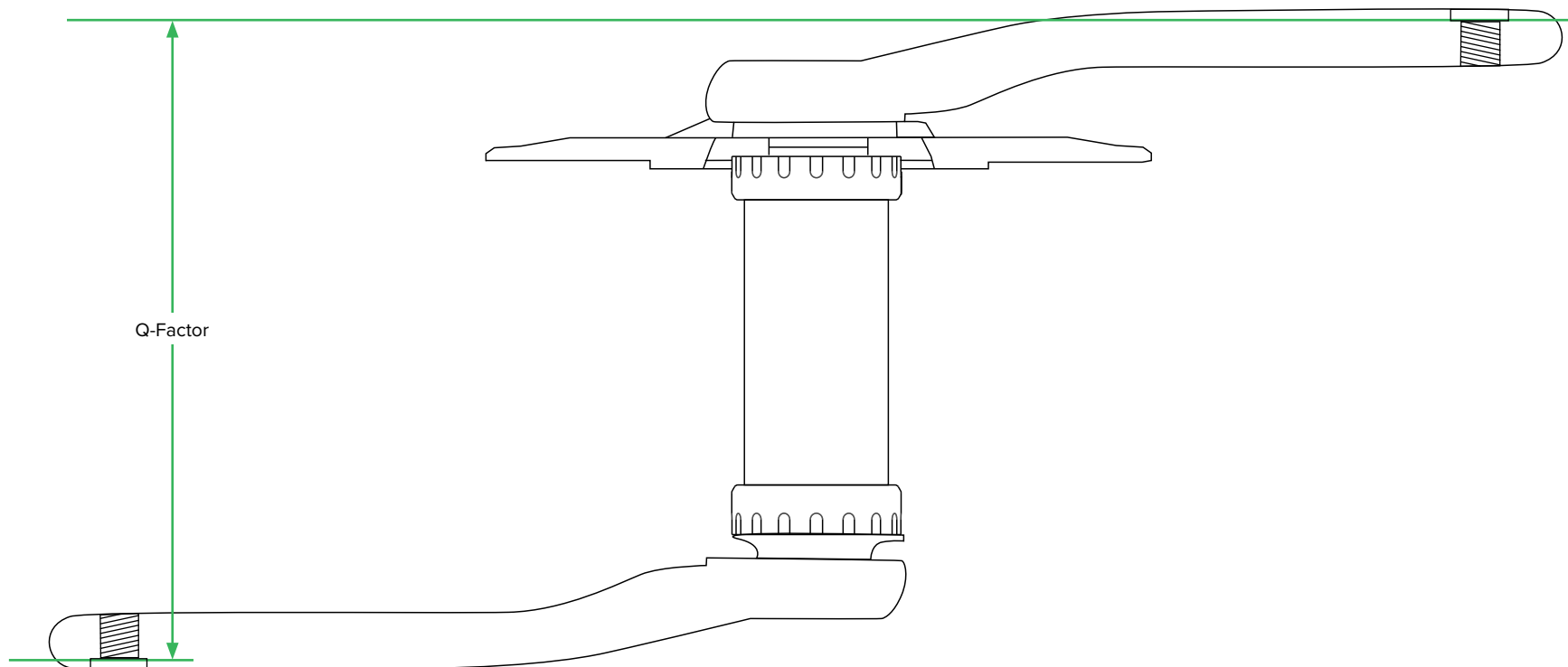

Crank Boot

Clearance Information

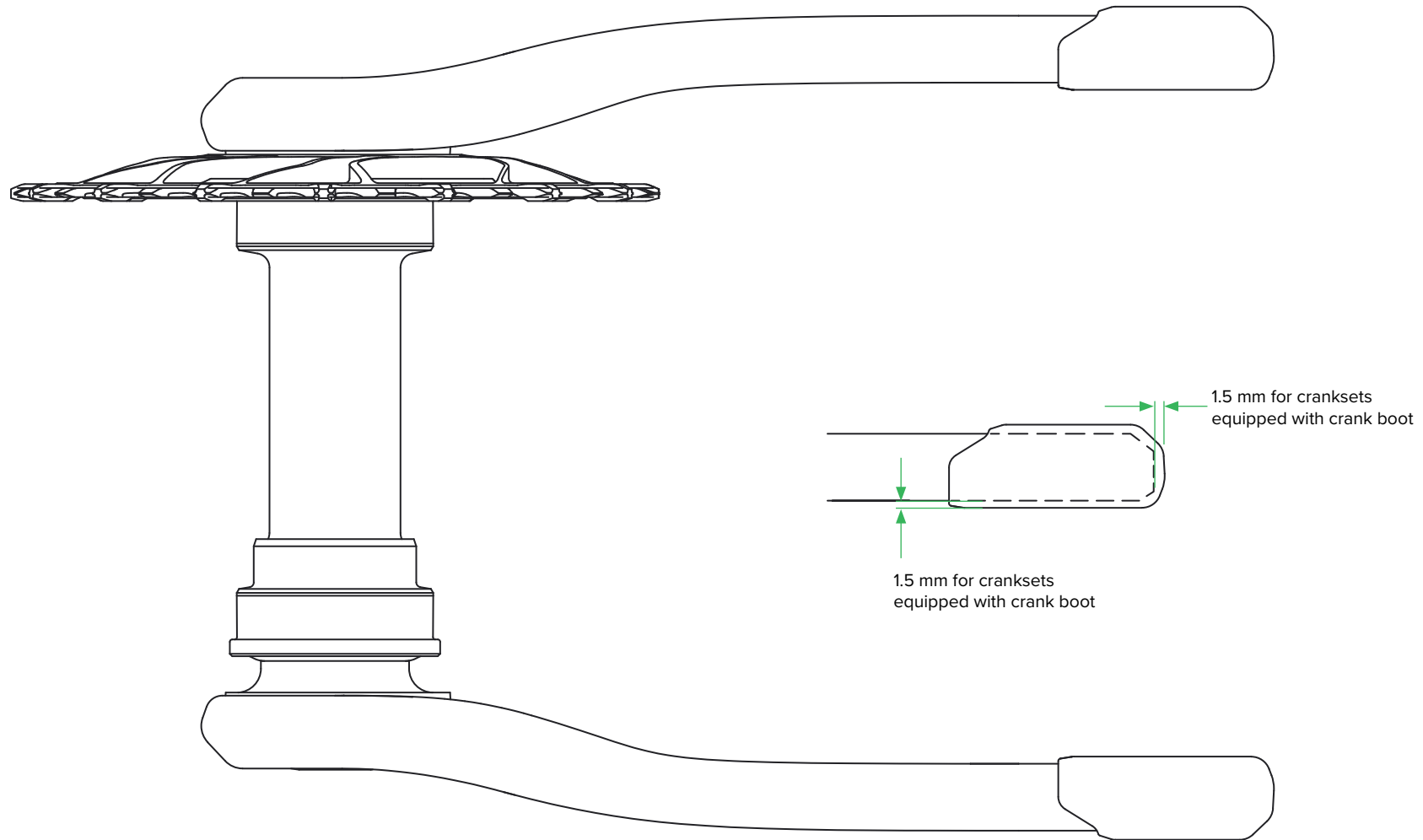

DUB Cranks

XX1 Eagle DUB

XX1 Eagle DUB

Drive Side Frame Clearance - BOOST and non-BOOST

Chainring		L1	L2	L3	L3 Oval*	W1	W2	CL	W5**				
		30T	non-BOOST & Eagle DUB 55 CL	27.2	29	64.3	68.3	47.2	47.2	49	70.6		
	BOOST	26.1	31.3										
32T	non-BOOST & Eagle DUB 55 CL	27.2	29	68.3	72.3								
		BOOST	26.1			31.3							
34T	non-BOOST & Eagle DUB 55 CL	27.2	29	72.4	76.4	50 (BOOST Variant)	50 (BOOST Variant)					52 (BOOST Variant)	70.6 (BOOST Variant)
		BOOST	26.1										
36T	non-BOOST & Eagle DUB 55 CL	27.2	29	76.4	80.4	53 (Eagle DUB 55 CL)	53 (Eagle DUB 55 CL)	55 (Eagle DUB 55 CL)	73.6 (Eagle DUB 55 CL)				
		BOOST	26.1							31.3			
38T	non-BOOST & Eagle DUB 55 CL	27.2	29	80.4	85.4								
		BOOST	26.1							31.3			

Q-factor : 168 (non-BOOST & BOOST) / 174 (Eagle DUB 55 CL) Bottom Bracket Type(s): DUB BSA 73 : DUB BB30 : DUB PF30 : DUB PF 89.5/92

*Oval chainrings available seperately, not with crank arms.

**Dimensions will vary for cranks equipped with crank boots. Consult the section titled "Crank Boot."

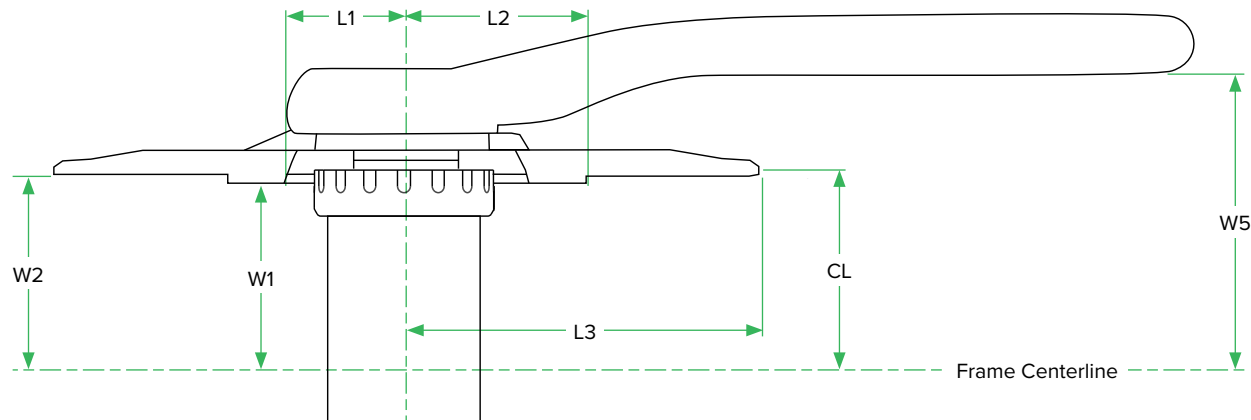

XX1 Eagle DUB

Non-Drive Frame Clearance

		W1	W2	W3	W4	W5	W6	W7*
1x12	X	25	35	65	85	105	130	190
	Y (non-BOOST & BOOST)	56	58	67.5	70	70.5	70.5	70.5
	Y (Eagle DUB 55 CL)	59	61	70.5	73	73.5	73.5	73.5
Q-factor : 168 (non-BOOST & BOOST) / 174 (Eagle DUB 55 CL)					Bottom Bracket Type(s): DUB BSA 73 : DUB BB30 : DUB PF30 : DUB PF 89.5/92			
*Dimensions will vary for cranks equipped with crank boots. Consult the Crank Boot Clearance Information page.								

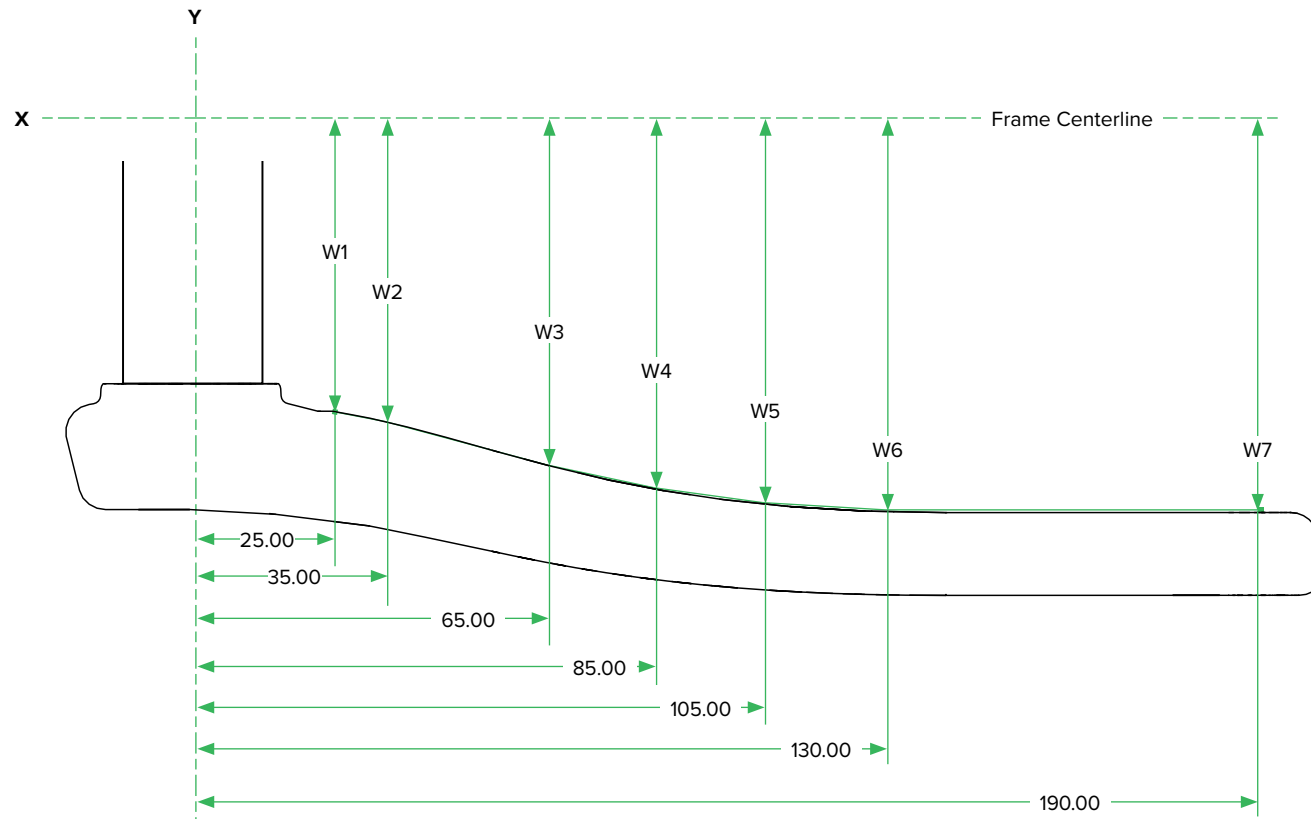

XX1 Eagle DUB Power Meter

Drive Side Frame Clearance*

1x12	Chainring	L1	L2	L3	W1	W2	CL	W5**
	30T	24.0	44.0	64.3	46.2	47.2 50 (BOOST Variant)	49 52 (BOOST Variant)	70.6
	32T			68.3				
	34T			72.4				
	36T			76.4				
	38T			80.4				
Q-factor : 168		Bottom Bracket Type(s): DUB BSA 73 : DUB BB30 : DUB PF30 : DUB PF 89.5/92						
*Dimensions are to the component and do not include clearance for debris. Consider additional frame clearance to compensate for mud/grit/debris picked up during normal riding conditions.								
**Dimensions will vary for cranks equipped with crank boots. Consult the section titled "Crank Boot."								

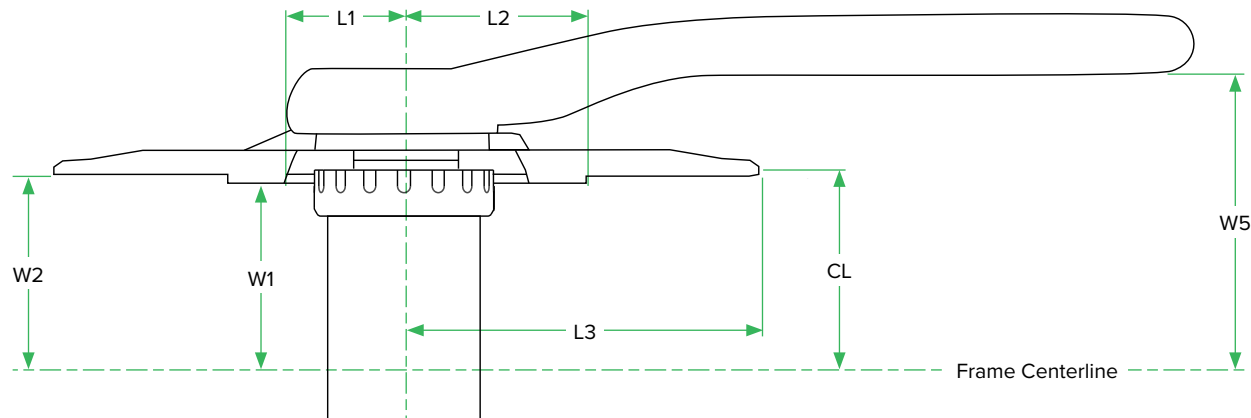

XX1 Eagle DUB Power Meter

Non-Drive Frame Clearance

		W1	W2	W3	W4	W5	W6	W7*
1x12	X	25	35	65	85	105	130	190
	Y	56	58	67.5	70	70.5	70.5	70.5
	Q-factor : 168		Bottom Bracket Type(s): DUB BSA 73 : DUB BB30 : DUB PF30 : DUB PF 89.5/92					
*Dimensions will vary for cranks equipped with crank boots. Consult the Crank Boot Clearance Information page.								

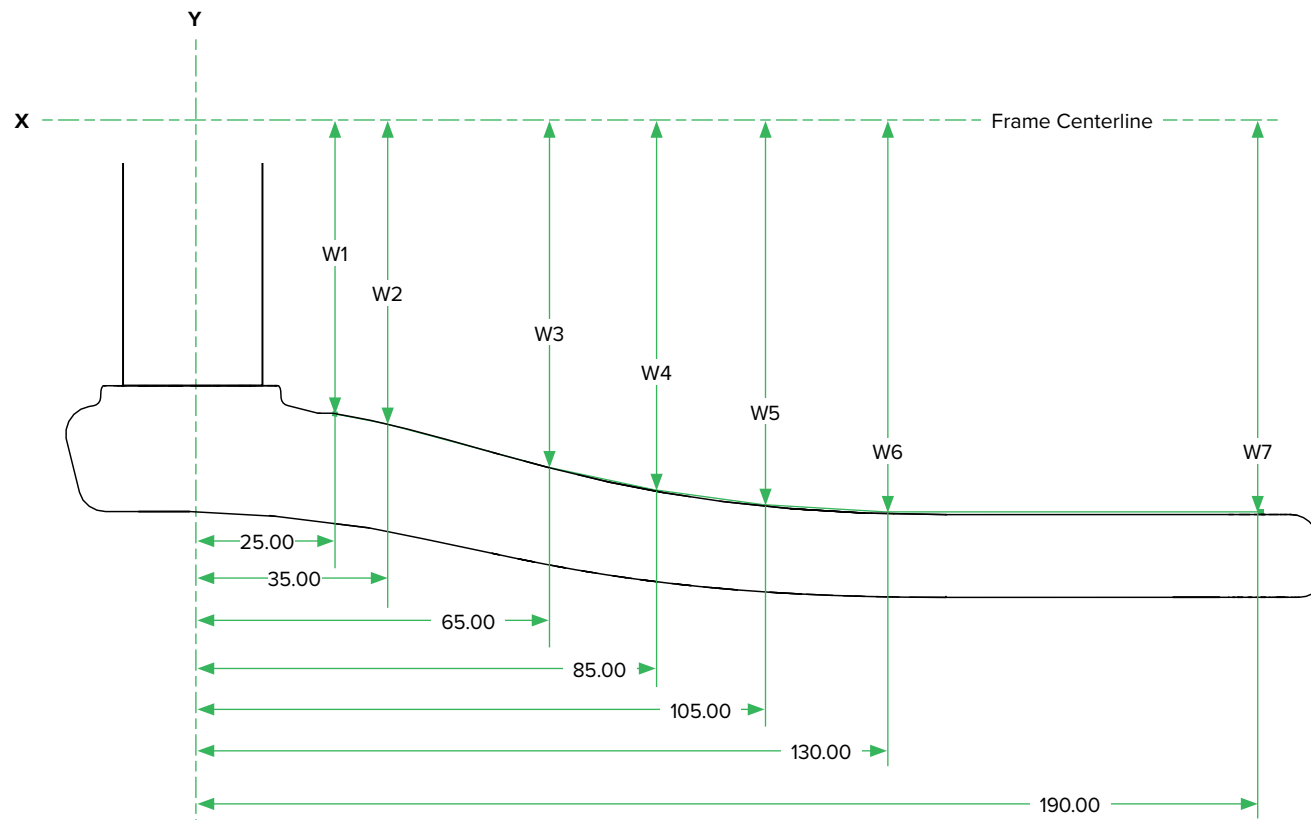

XX1 Eagle DUB - Fatbike

Drive Side Frame Clearance

1x12	Chainring		L1	L2	L3	W1	W2	CL	W5
	30T	4" Fatbike (170 OLD)	27.2	29	64.3	64.7	64.7	66.5	88.1
		5" Fatbike (190 OLD)	22.8	29		70	74.7	76.5	
Q-factor : 203.3				Bottom Bracket Type(s): DUB BSA 100 : DUB PF 121					

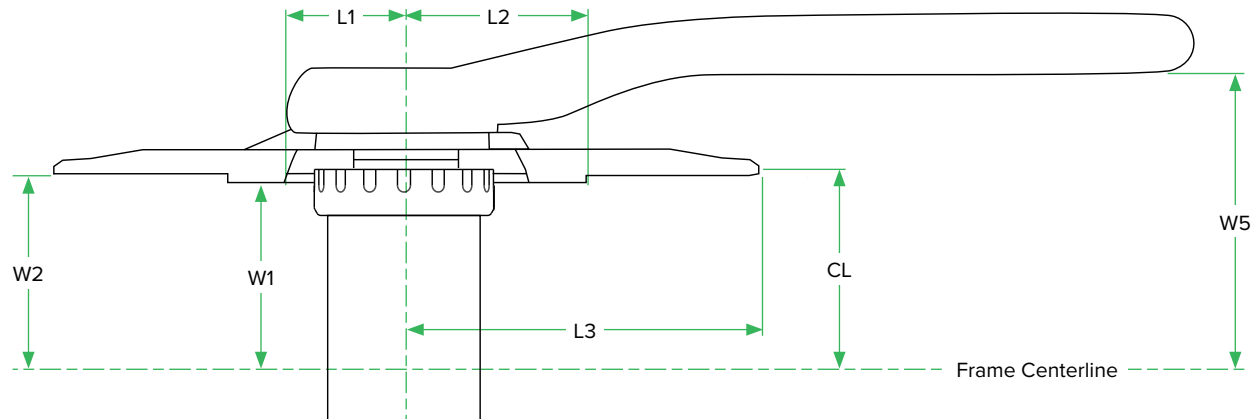

XX1 Eagle DUB - Fatbike

Non-Drive Frame Clearance

		W1	W2	W3	W4	W5	W6	W7
1x12	X	25	35	65	85	105	130	190
	Y	75.5	77	84	86.5	87.5	88	88
Q-factor : 203.3		Bottom Bracket Type(s): DUB BSA 100 : DUB PF 121						

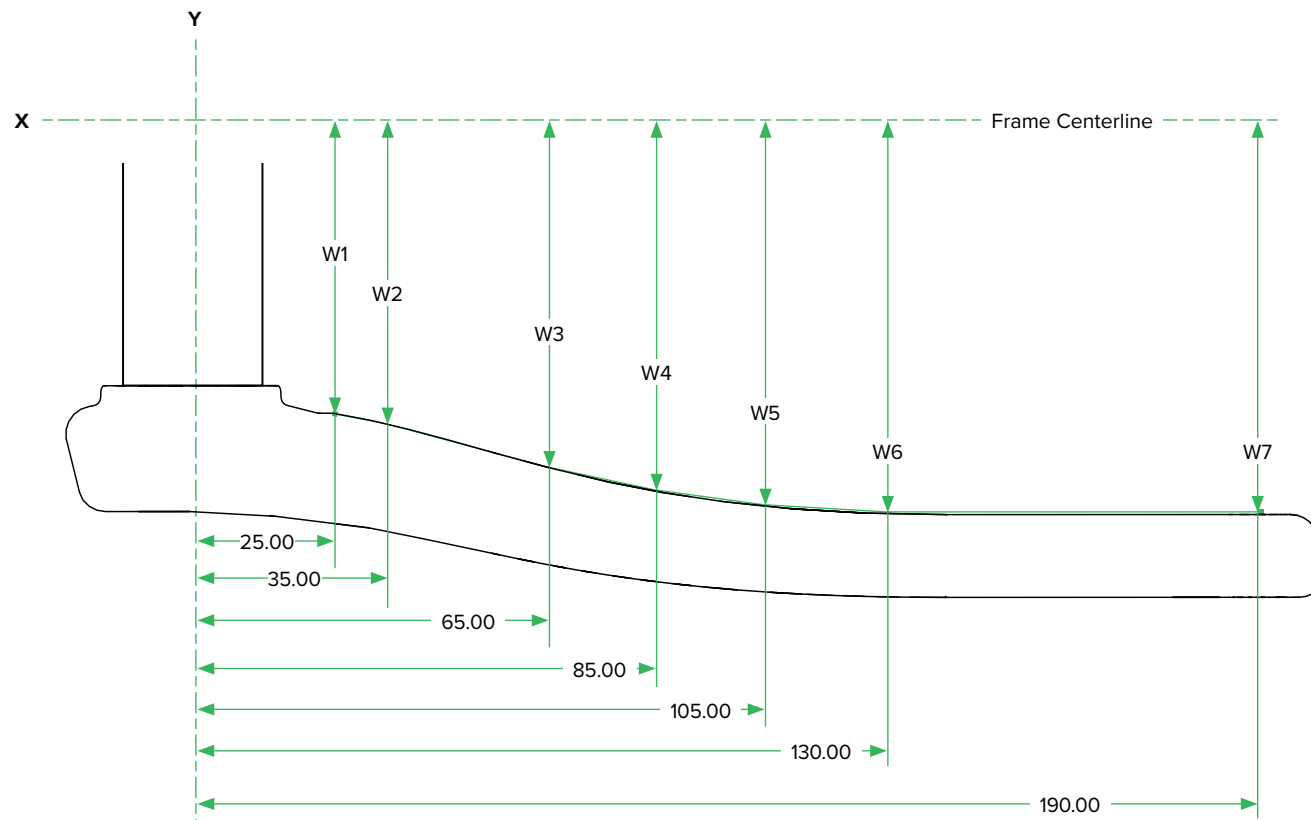

X01 Eagle DUB

X01 Eagle DUB

Drive Side Frame Clearance - BOOST and non-BOOST

Chainring		L1	L2	L3	W1	W2	CL	W5**
		30T	non-BOOST & Eagle DUB 55 CL	27.2	29	64.3	47.2	47.2
	BOOST	26.1	31.3					
32T	non-BOOST & Eagle DUB 55 CL	27.2	29	68.3	50 (BOOST Variant)	50 (BOOST Variant)	52 (BOOST Variant)	70.6 (BOOST Variant)
		BOOST	26.1					
34T	non-BOOST & Eagle DUB 55 CL	27.2	29	72.4	53 (Eagle DUB 55 CL)	53 (Eagle DUB 55 CL)	55 (Eagle DUB 55 CL)	73.6 (Eagle DUB 55 CL)
		BOOST	26.1					
36T	non-BOOST & Eagle DUB 55 CL	27.2	29	76.4	53 (Eagle DUB 55 CL)	53 (Eagle DUB 55 CL)	55 (Eagle DUB 55 CL)	73.6 (Eagle DUB 55 CL)
		BOOST	26.1					

Q-factor : 168 (non-BOOST & BOOST) / 174 (Eagle DUB 55 CL) Bottom Bracket Type(s): DUB BSA 73 : DUB BB30 : DUB PF30 : DUB PF 89.5/92

*Dimensions will vary for cranks equipped with crank boots. Consult the section titled "Crank Boot."

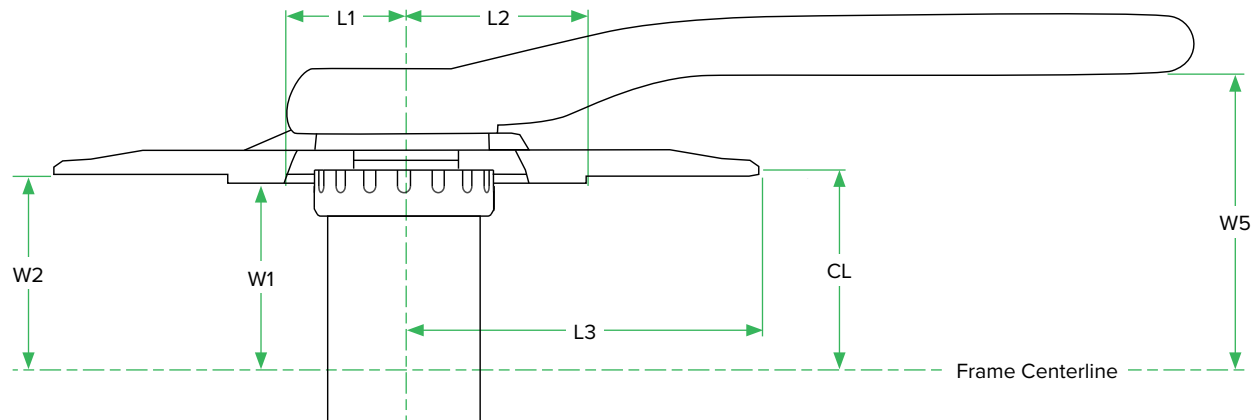

X01 Eagle DUB

Non-Drive Frame Clearance

		W1	W2	W3	W4	W5	W6	W7*
1x12	X	25	35	65	85	105	130	190
	Y (non-BOOST & BOOST)	56	58	67.5	70	70.5	70.5	70.5
	Y (Eagle DUB 55 CL)	59	61	70.5	73	73.5	73.5	73.5
Q-factor : 168 (non-BOOST & BOOST) / 174 (Eagle DUB 55 CL)					Bottom Bracket Type(s): DUB BSA 73 : DUB BB30 : DUB PF30 : DUB PF 89.5/92			
*Dimensions will vary for cranks equipped with crank boots. Consult the Crank Boot Clearance Information page.								

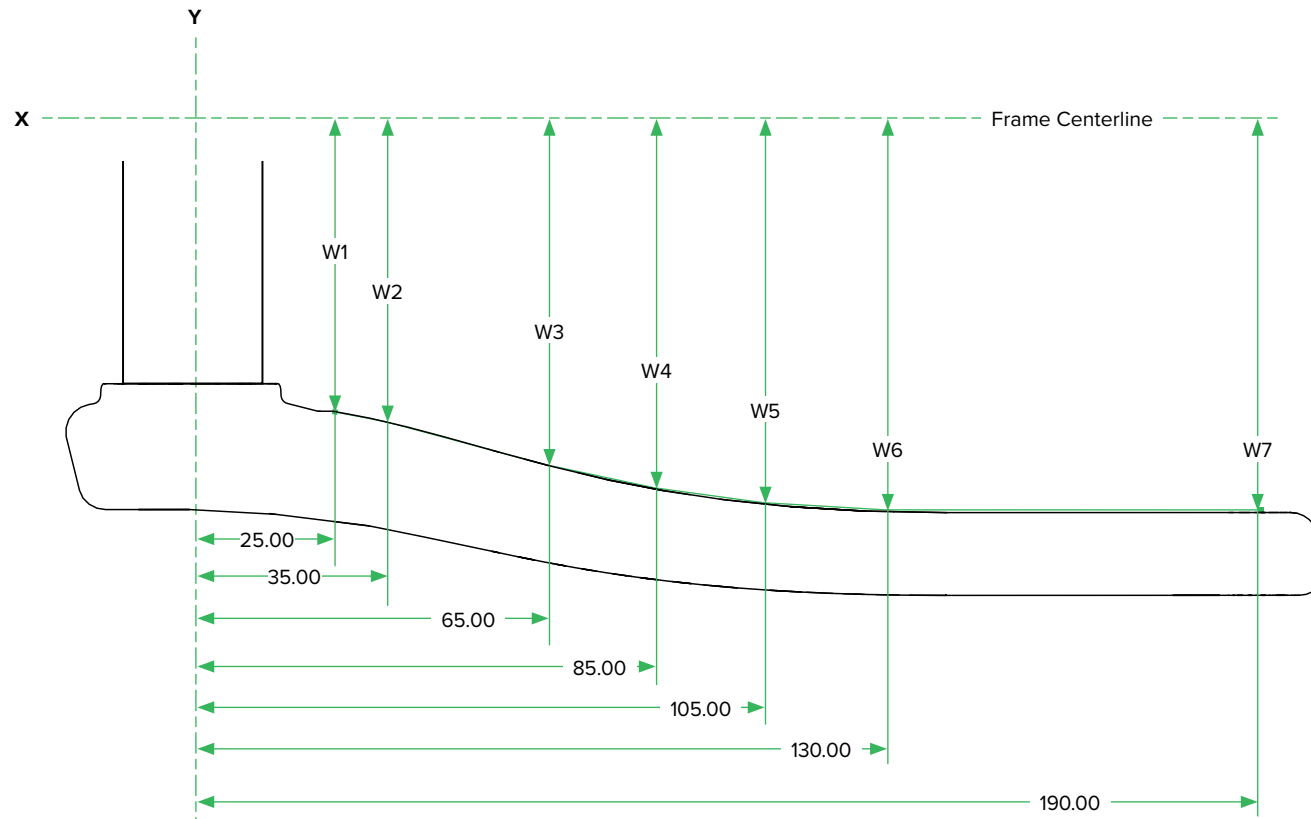

X01 Eagle DUB SB+

Drive Side Frame Clearance

1x12	Chainring	L1	L2	L3	W1	W2	CL	W5*
	30T	26.1	31.3	64.3	54.7	54.7	56.5	75.1
	32T			68.3				
	34T			72.4				
	36T			76.4				
Q-factor : 176.8		Bottom Bracket Type(s): DUB BSA 73 SB+ : DUB PF 92 SB+						
*Dimensions will vary for cranks equipped with crank boots. Consult the section titled "Crank Boot."								

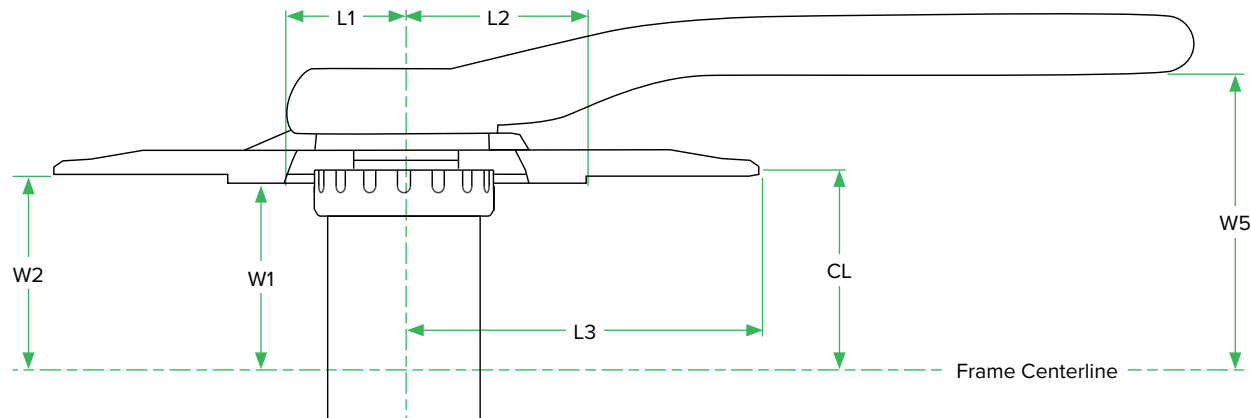

X01 Eagle DUB SB+

Non-Drive Frame Clearance

		W1	W2	W3	W4	W5	W6	W7*	
1x12	X	25	35	65	85	105	130	190	
	Y	62.6	64.1	71.1	73.6	74.6	75.1	75.1	
	Q-factor : 176.8		Bottom Bracket Type(s): DUB BSA 73 SB+ : DUB PF 92 SB+						
	*Dimensions will vary for cranks equipped with crank boots. Consult the Crank Boot Clearance Information page.								

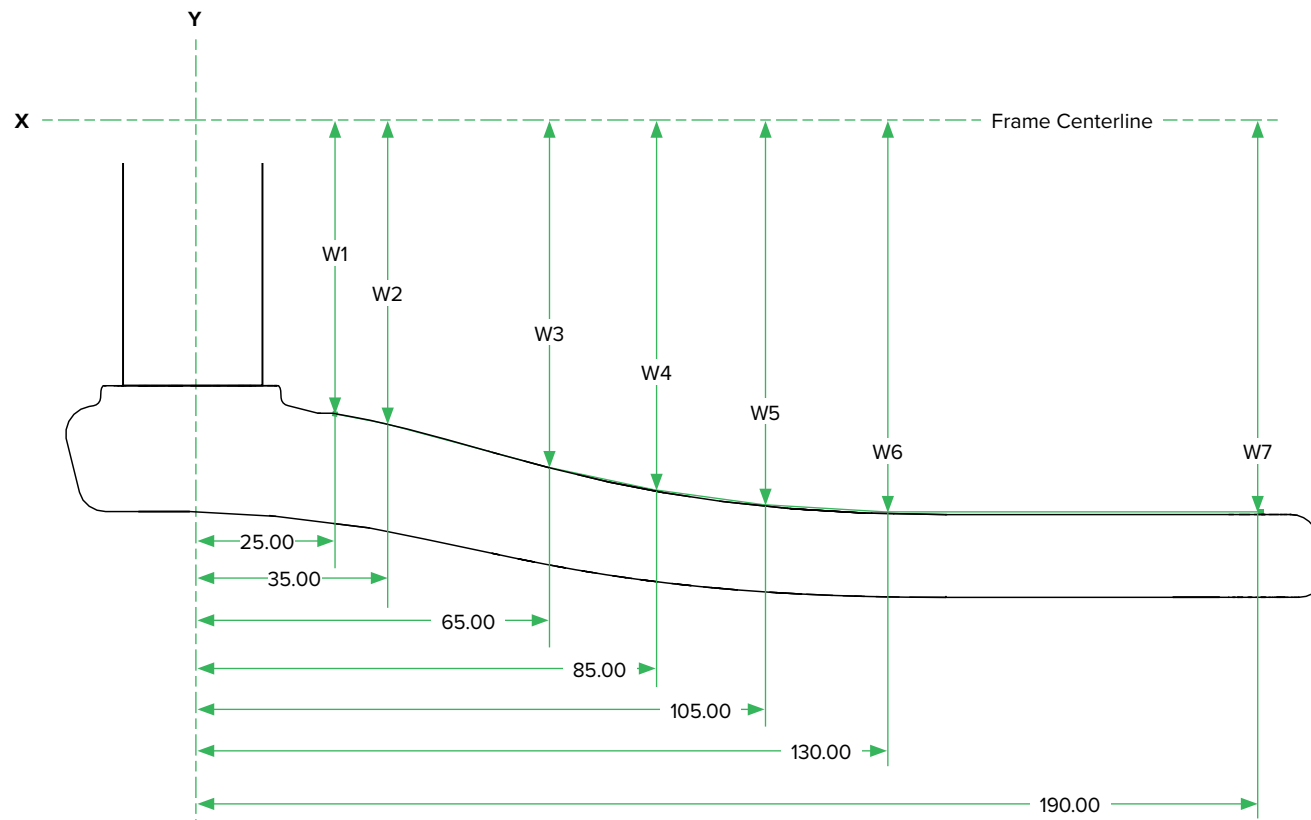

X01 Eagle DUB - Fatbike

Drive Side Frame Clearance

1x12	Chainring		L1	L2	L3	W1	W2	CL	W5
	30T	4" Fatbike (170 OLD)	27.2	29	64.3	64.7	64.7	66.5	88.1
		5" Fatbike (190 OLD)	22.8	29		70	74.7	76.5	
Q-factor : 203.3				Bottom Bracket Type(s): DUB BSA 100 : DUB PF 121					

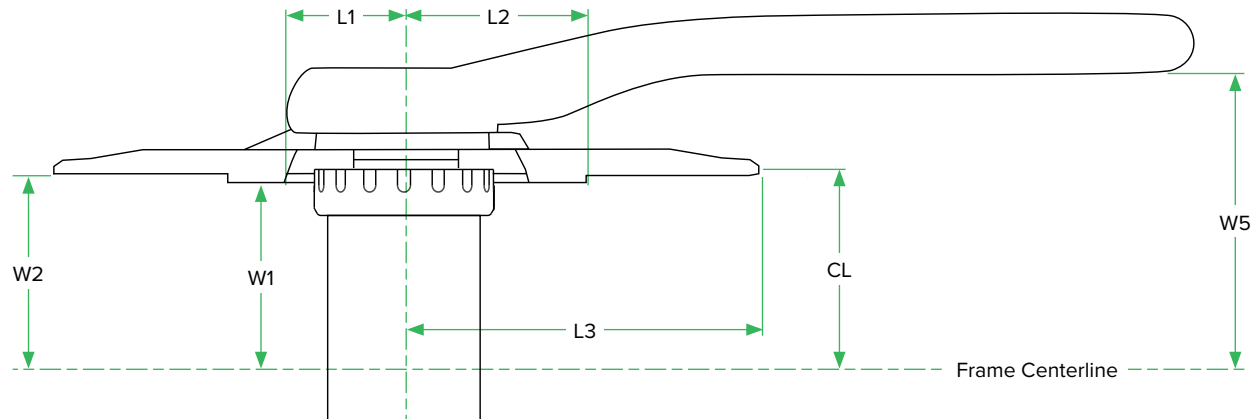

X01 Eagle DUB - Fatbike

Non-Drive Frame Clearance

		W1	W2	W3	W4	W5	W6	W7
1x12	X	25	35	65	85	105	130	190
	Y	75.5	77	84	86.5	87.5	88	88
	Q-factor : 203.3		Bottom Bracket Type(s): DUB BSA 100 : DUB PF 121					

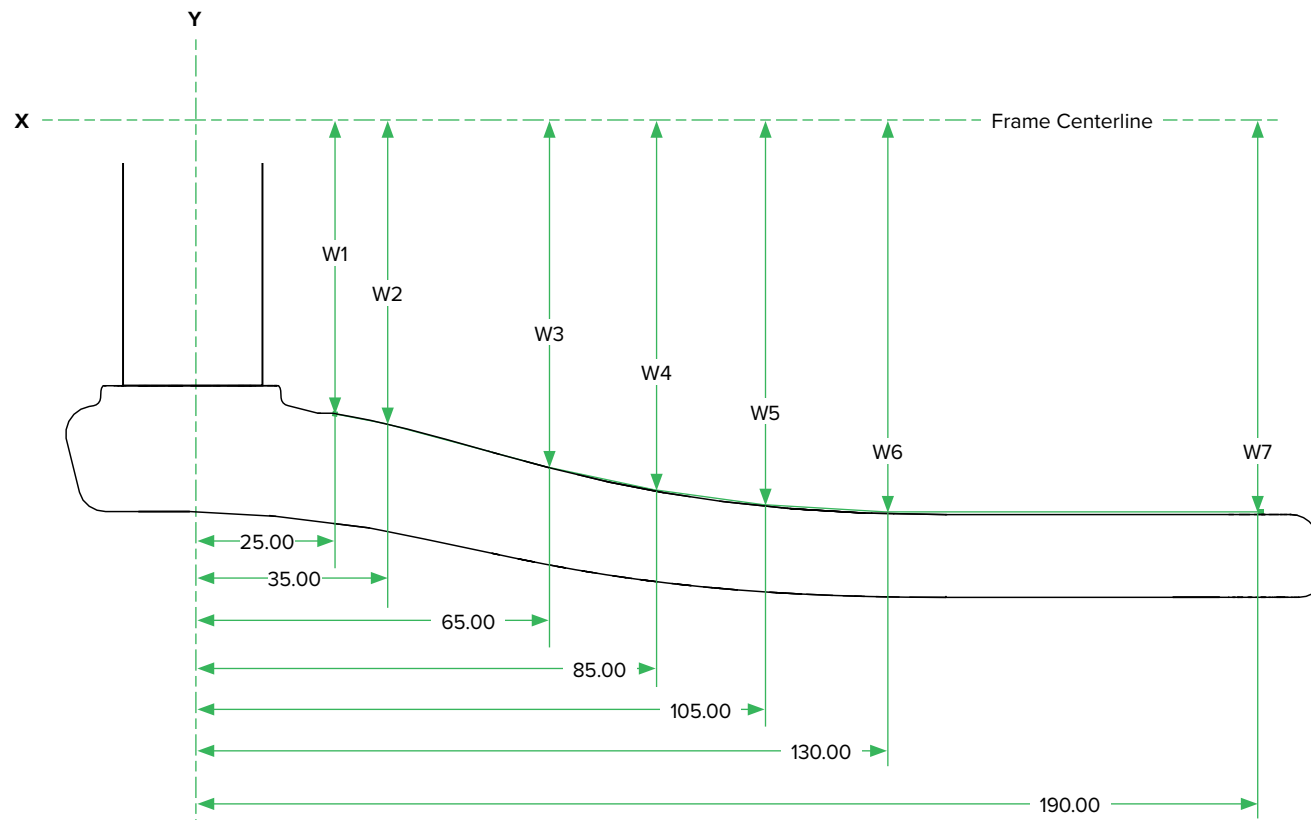

X01 DH

X01 EAGLE DH DUB73

Drive Side Frame Clearance - BOOST and non-BOOST

1x12	Chainring		L1	L2	L3	W1	W2	CL	W5**				
	30T	non-BOOST	27.2	29	64.3	47.2	47.2	49	70.6				
		BOOST	26.1	31.3									
	32T	non-BOOST	27.2	29	68.3								
		BOOST	26.1	31.3									
	34T	non-BOOST	27.2	29	72.4					50 (BOOST Variant)	50 (BOOST Variant)	52 (BOOST Variant)	70.6 (BOOST Variant)
		BOOST	26.1	31.3									
36T	non-BOOST	27.2	29	76.4									
	BOOST	26.1	31.3										
Q-factor : 168 (non-BOOST & BOOST)						Bottom Bracket Type(s): DUB BSA 73 : DUB BB30 : DUB PF30 : DUB PF 89.5/92							
*Dimensions will vary for cranks equipped with crank boots. Consult the section titled "Crank Boot."													

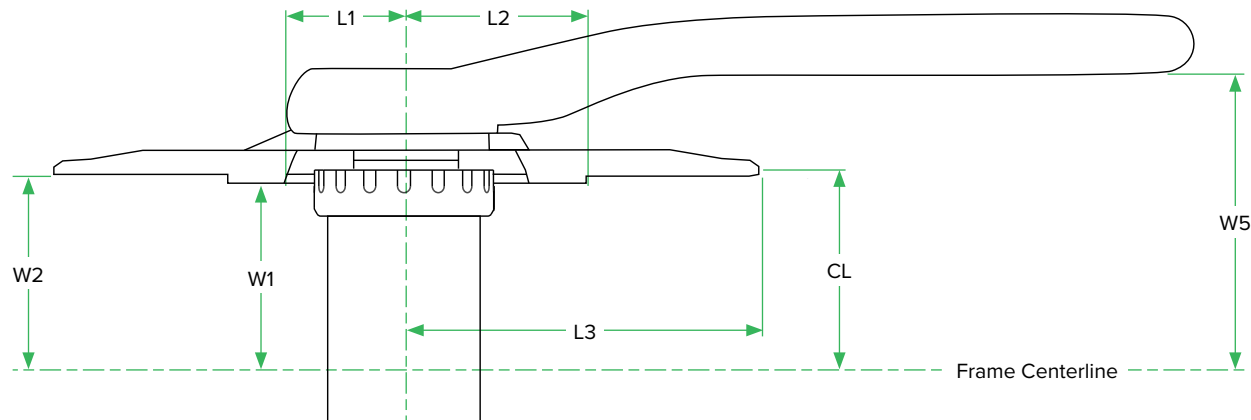

X01 EAGLE DH DUB73

Non-Drive Frame Clearance

		W1	W2	W3	W4	W5	W6	W7*
1x12	X	25	35	65	85	105	130	190
	Y (non-BOOST & BOOST)	56	58	67.5	70	70.5	70.5	70.5
	Q-factor : 168 (non-BOOST & BOOST)				Bottom Bracket Type(s): DUB BSA 73 : DUB BB30 : DUB PF30 : DUB PF 89.5/92			
*Dimensions will vary for cranks equipped with crank boots. Consult the Crank Boot Clearance Information page.								

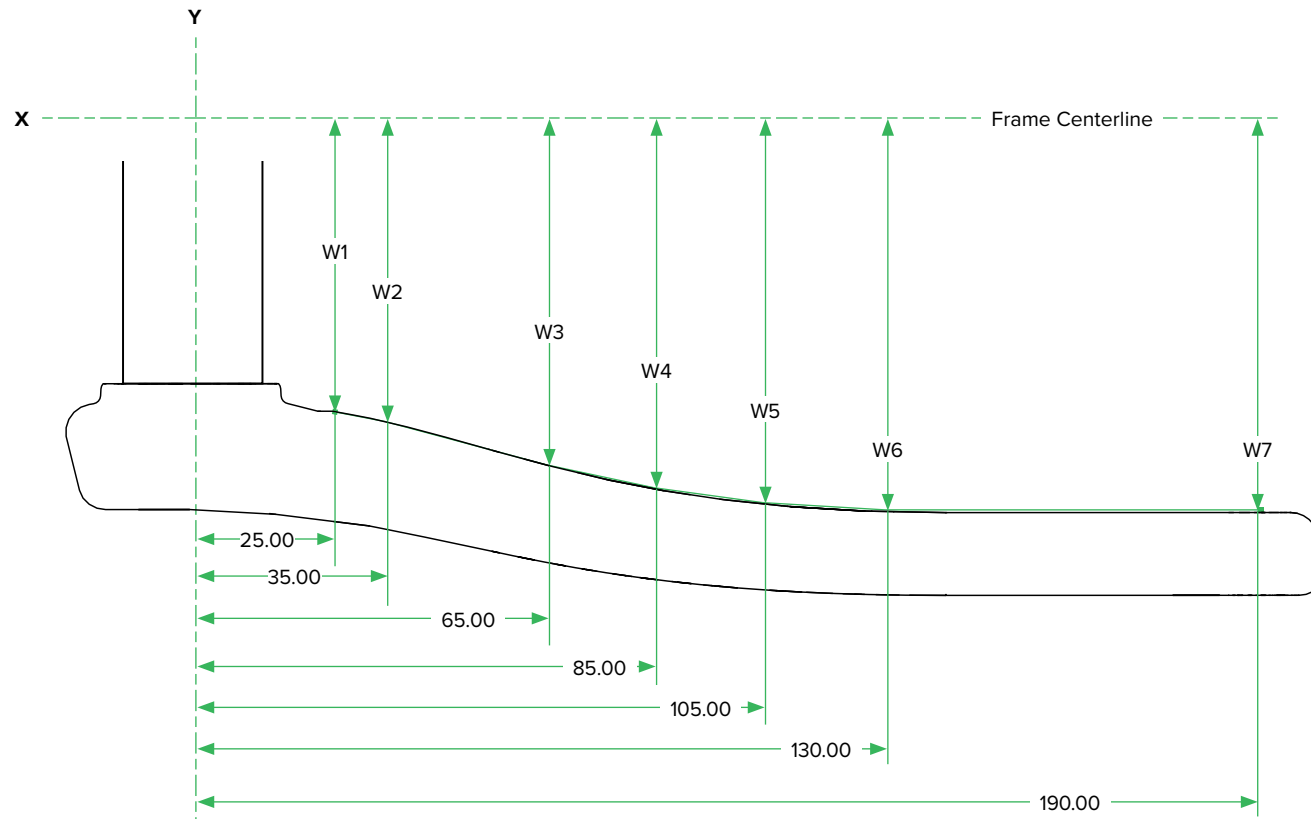

X01 DH DUB

Drive Side Frame Clearance

	Chainring	L1	L2	L3	W1	W2	CL	W5
1x7	34T	27.2	29	72.4	54.7	54.7	56.5	78.1
	36T			76.4				
Q-factor : 183			Bottom Bracket Type(s): DUB BSA 83 : DUB PF 104.5/107					

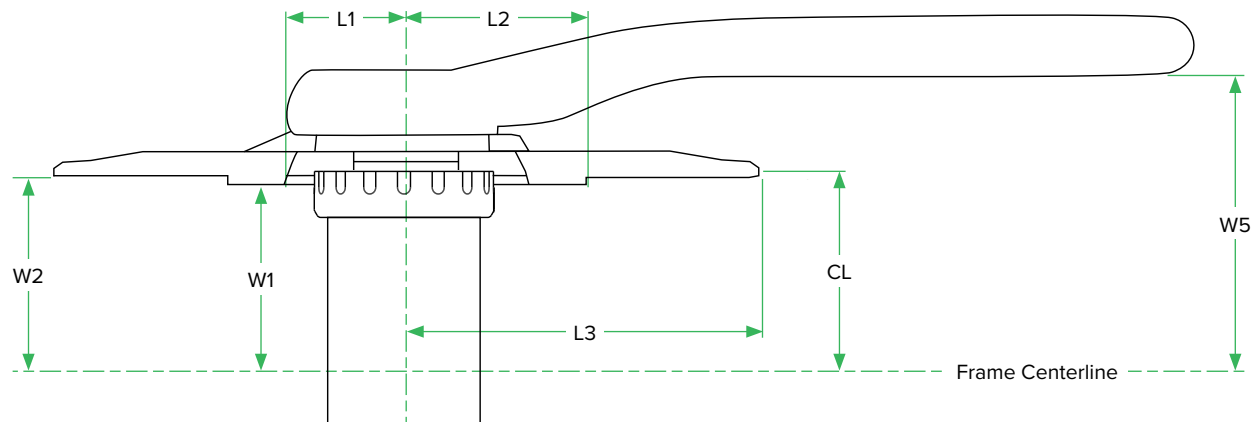

X01 DH DUB

Non-Drive Frame Clearance

		W1	W2	W3	W4	W5	W6	W7
1x7	X	25	35	65	85	105	130	190
	Y	64.7	67.3	74.3	76.8	77.8	78.3	78.3
Q-factor : 183		Bottom Bracket Type(s): DUB BSA 83 : DUB PF 104.5/107						

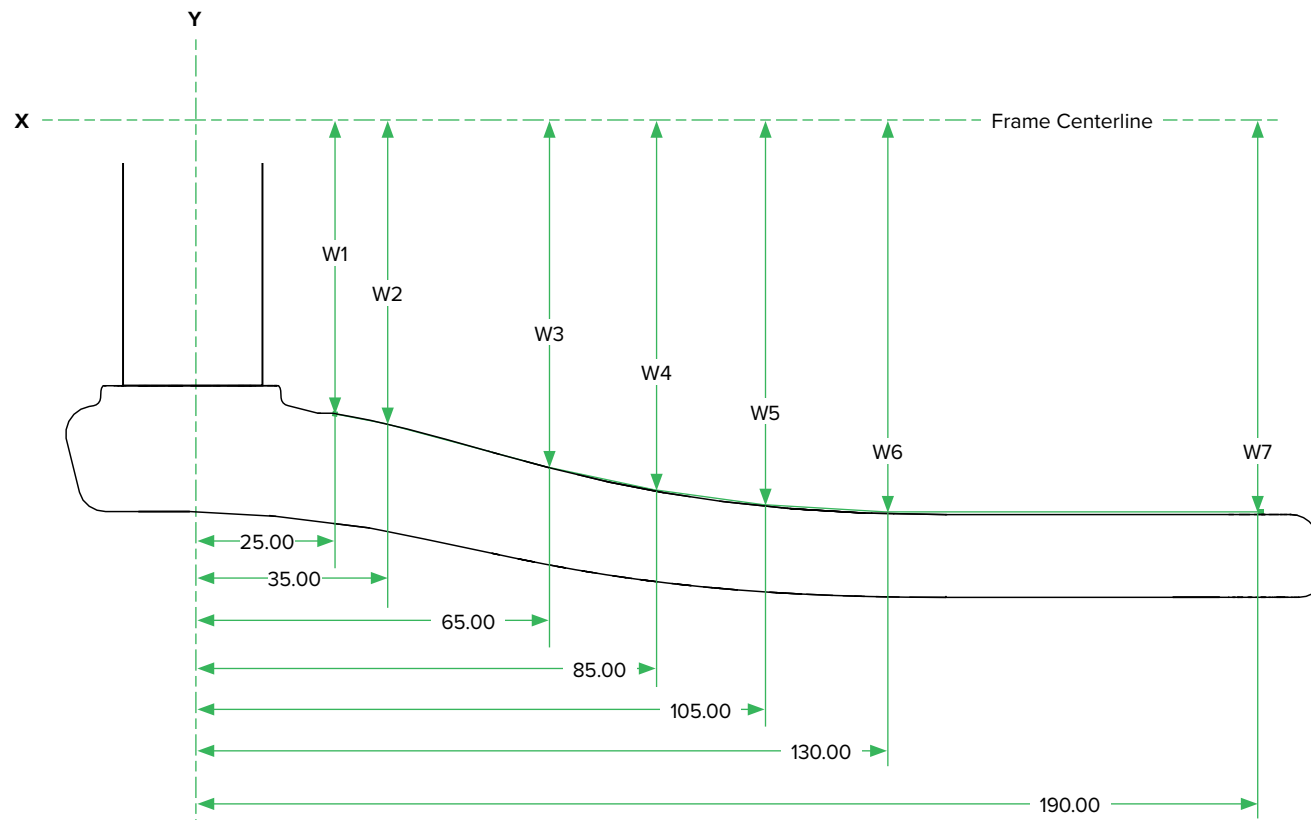

X01 DH DUB73

Drive Side Frame Clearance

	Chainring	L1	L2	L3	W1	W2	CL	W5
1x7	34T	27.2	29	72.4	54.7	54.7	56.5	78.1
	36T			76.4				
Q-factor : 183		Bottom Bracket Type(s): DUB BSA 73						

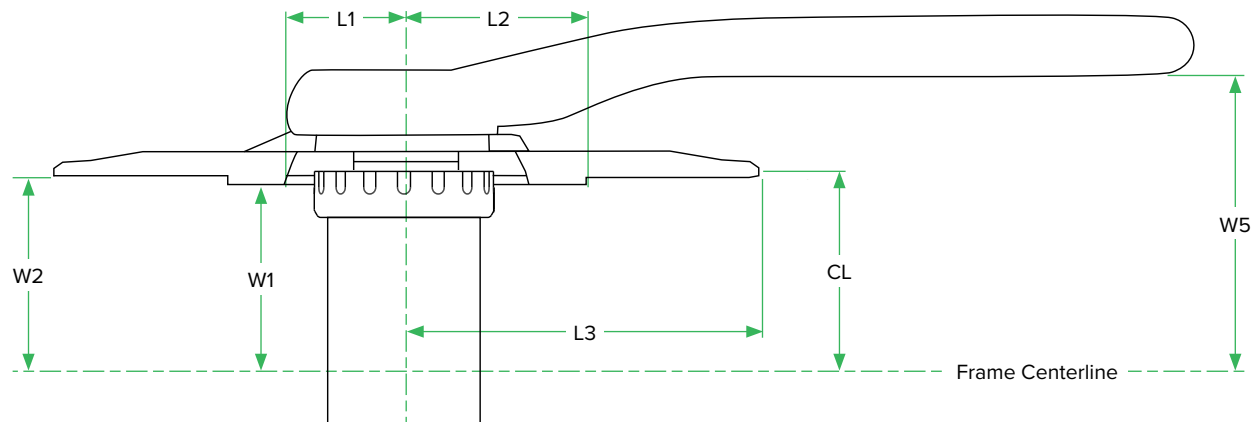

X01 DH DUB73

Non-Drive Frame Clearance

		W1	W2	W3	W4	W5	W6	W7
1x7	X	25	35	65	85	105	130	190
	Y	64.7	67.3	74.3	76.8	77.8	78.3	78.3
	Q-factor : 183		Bottom Bracket Type(s): DUB BSA 73					

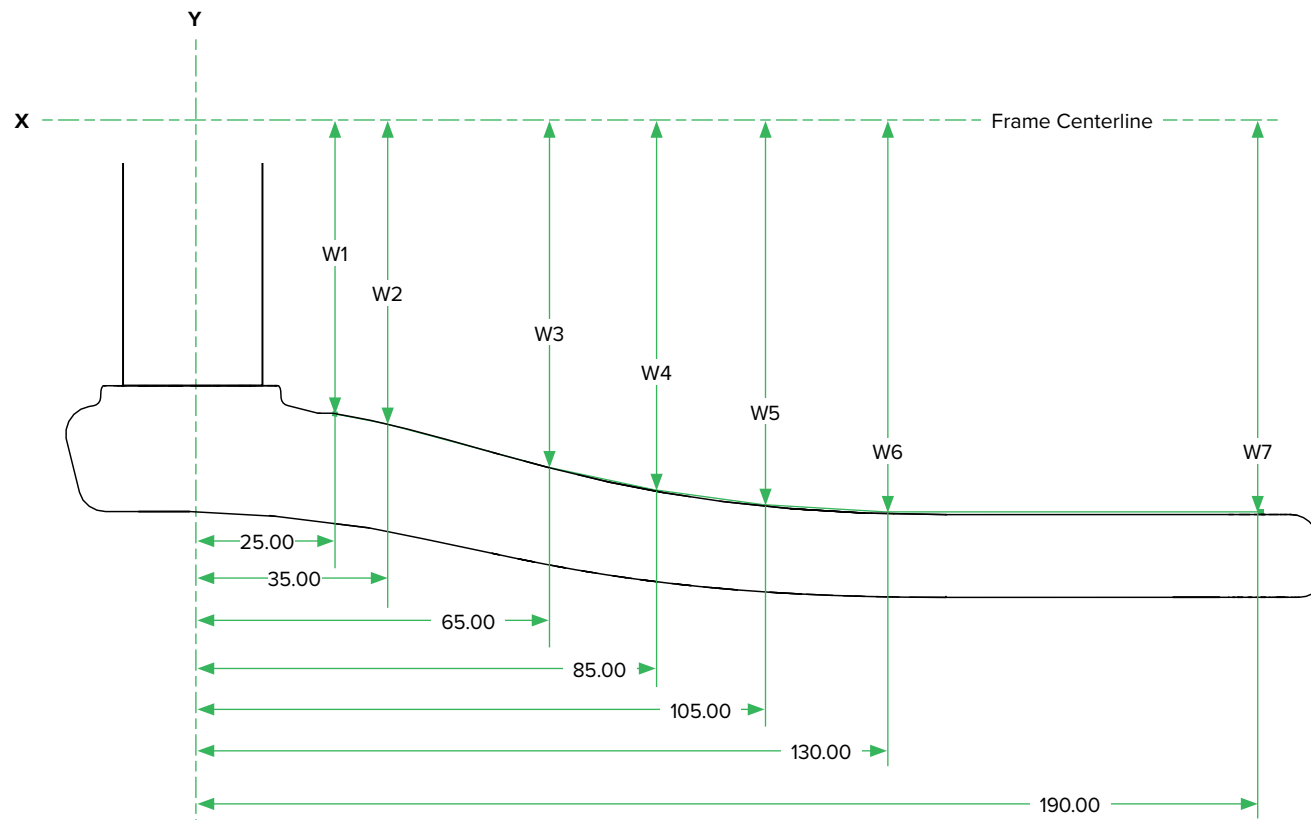

X1 Carbon Eagle DUB/
Descendant Carbon Eagle DUB/
Stylo Carbon Eagle DUB

X1 Carbon Eagle DUB/Descendant Carbon Eagle DUB/Stylo Carbon Eagle DUB

Drive Side Frame Clearance - BOOST and non-BOOST

1x12	Chainring		L1	L2	L3	W1	W2	CL	W5**
	30T	non-BOOST & Eagle DUB 55 CL	31.5	31.5	50.7	64.3	48	47.3	49
	BOOST	51.3							
32T	non-BOOST & Eagle DUB 55 CL	54.7			68.3	51 (BOOST Variant)	50.3 (BOOST Variant)	52 (BOOST Variant)	72 (BOOST Variant)
		BOOST							
34T	non-BOOST & Eagle DUB 55 CL	58.7			72.3	54 (Eagle DUB 55 CL)	53.3 (Eagle DUB 55 CL)	55 (Eagle DUB 55 CL)	75 (Eagle DUB 55 CL)
		BOOST							
Q-factor : 169 (non-BOOST & BOOST) / 175 (Eagle DUB 55 CL)						Bottom Bracket Type(s): DUB BSA 73 : DUB BB30 : DUB PF30 : DUB PF 89.5/92			
*Dimensions will vary for cranks equipped with crank boots. Consult the section titled "Crank Boot."									

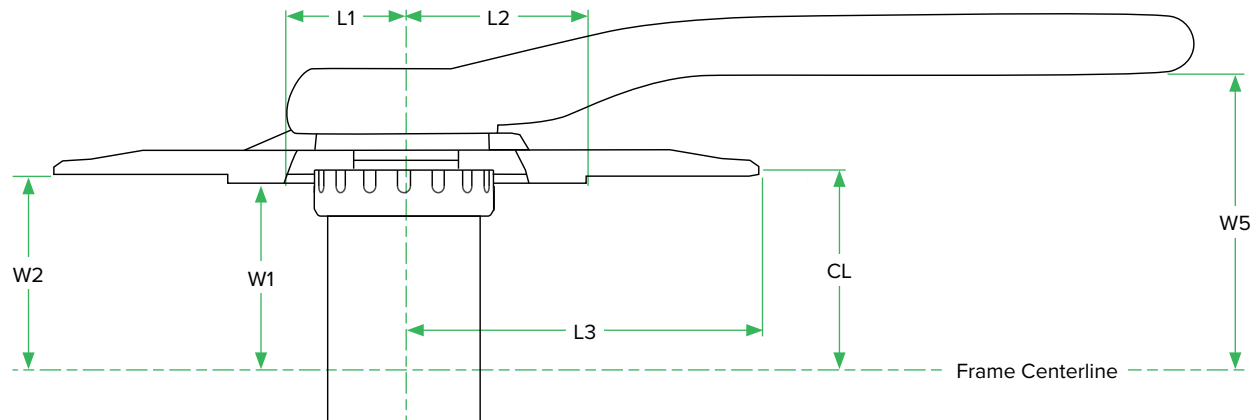

X1 Carbon Eagle DUB/Descendant Carbon Eagle DUB/Stylo Carbon Eagle DUB

Non-Drive Frame Clearance

		W1	W2	W3	W4	W5	W6	W7*
1x12	X	25	35	65	85	105	130	190
	Y (non-BOOST & BOOST)	59	61	67.5	70.5	71	71	71.5
	Y (Eagle DUB 55 CL)	62	64	70.5	73.5	74	74	74.5
Q-factor : 169 (non-BOOST & BOOST) / 175 (Eagle DUB 55 CL)					Bottom Bracket Type(s): DUB BSA 73 : DUB BB30 : DUB PF30 : DUB PF 89.5/92			
*Dimensions will vary for cranks equipped with crank boots. Consult the Crank Boot Clearance Information page.								

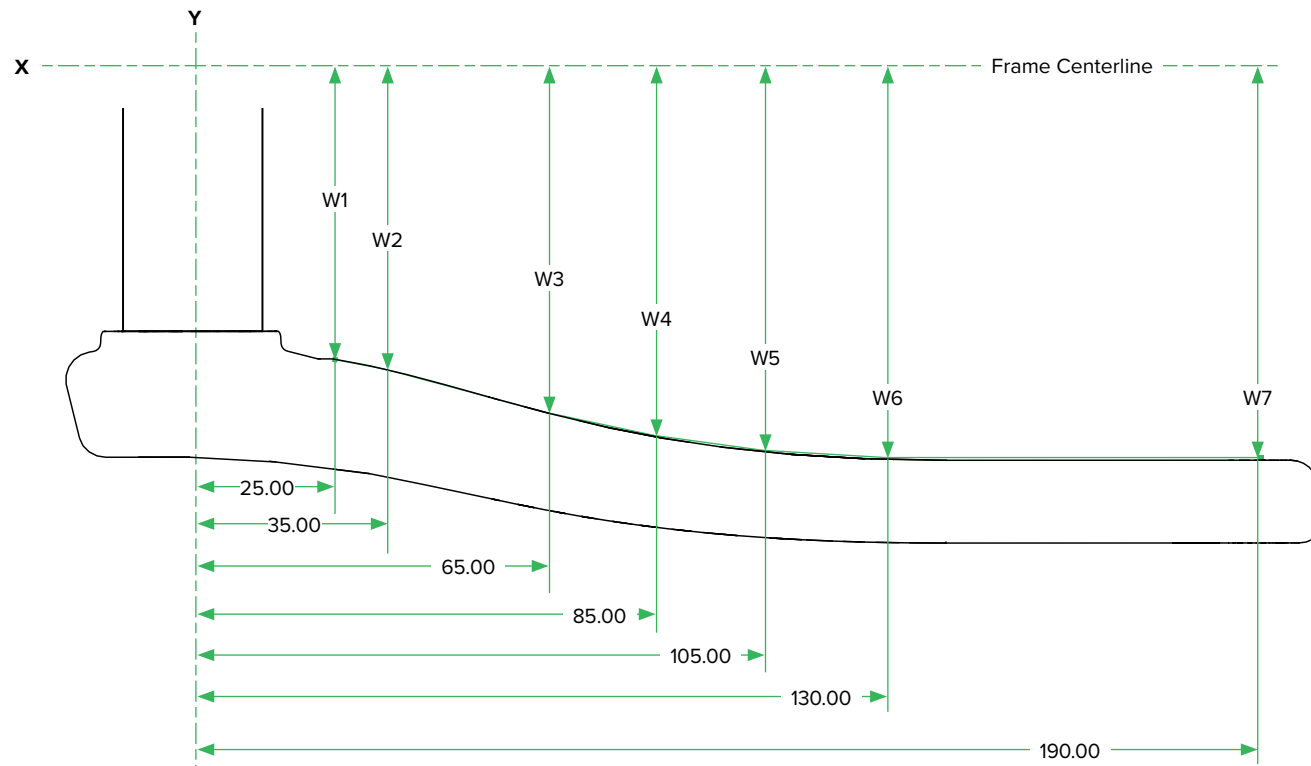

X1 Carbon Eagle DUB/Descendant Carbon Eagle DUB/Stylo Carbon Eagle DUB - Fatbike

Drive Side Frame Clearance - BOOST and non-BOOST

1x12	Chainring		L1	L2	L3	W1	W2	CL	W5
	30T	4" Fatbike (170 OLD)	31.5	50.7	64.3	65.5	64.8	66.5	89.5
		5" Fatbike (190 OLD)	22.8	29		70	74.7	76.5	
Q-factor : 204.5				Bottom Bracket Type(s): DUB BSA 100 : DUB PF 121					

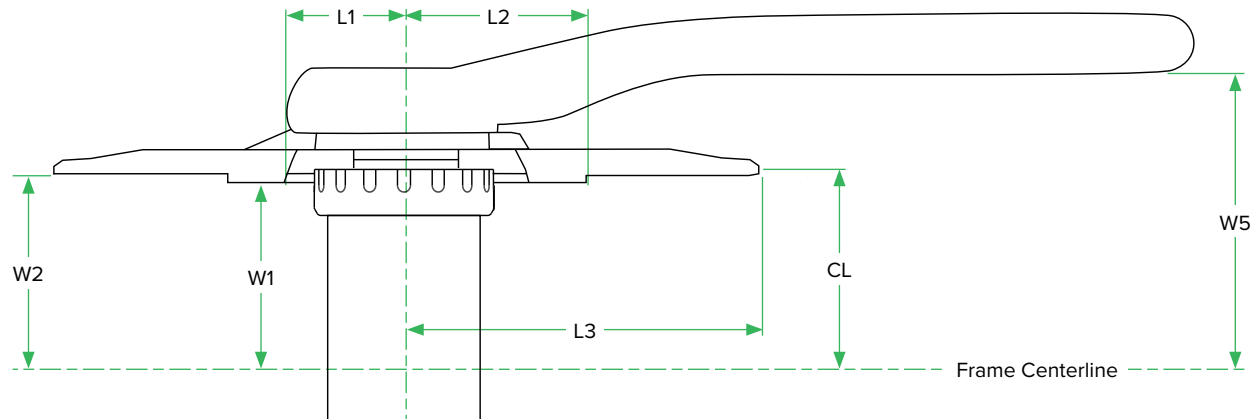

X1 Carbon Eagle DUB/Descendant Carbon Eagle DUB/Stylo Carbon Eagle DUB - Fatbike

Non-Drive Frame Clearance

		W1	W2	W3	W4	W5	W6	W7
1x12	X	25	35	65	85	105	130	190
	Y	77	79	85.5	88.5	89	89	89.5
	Q-factor : 204.5		Bottom Bracket Type(s): DUB BSA 100 : DUB PF 121					

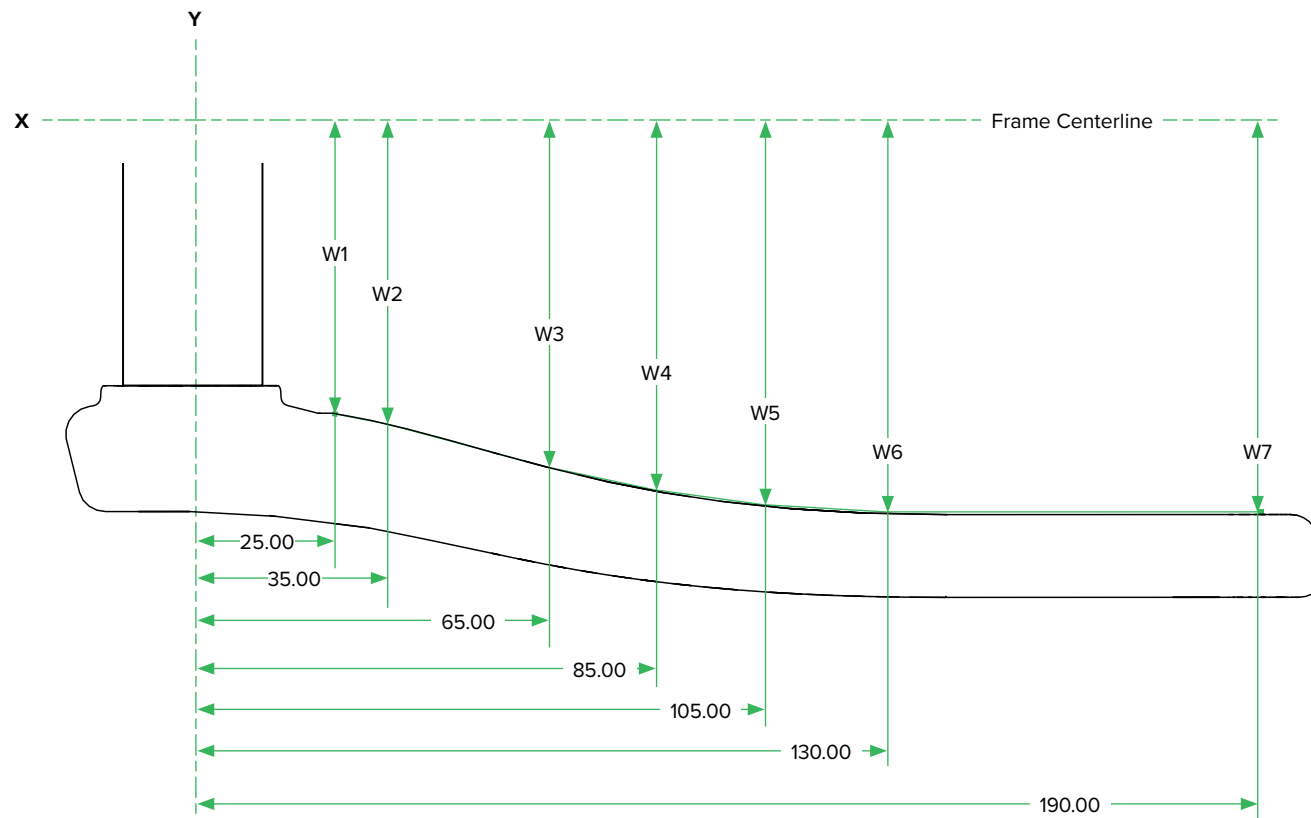

GX Eagle DUB

GX Eagle DUB

Drive Side Frame Clearance - BOOST and non-BOOST

1x12	Chainring		L1	L2	L3	W1	W2	CL	W5*	
	30T	non-BOOST & Eagle DUB 55 CL	35.2	50.7	64.3	48	47.2	49	71.7	
		BOOST	31.5	58.7						
	32T	non-BOOST & Eagle DUB 55 CL	27	54.7	68.3	51 (BOOST Variant)	50.2 (BOOST Variant)	52 (BOOST Variant)	71.7 (BOOST Variant)	
		BOOST	29.3	55.2						
	34T	non-BOOST & Eagle DUB 55 CL	31.5	58.7	72.3	54 (Eagle DUB 55 CL)	53.2 (Eagle DUB 55 CL)	55 (Eagle DUB 55 CL)	74.7 (Eagle DUB 55 CL)	
		BOOST	31.5	59.2						
	Q-factor : 169 (non-BOOST & BOOST) / 175 (Eagle DUB 55 CL)						Bottom Bracket Type(s): DUB BSA 73 : DUB BB30 : DUB PF30 : DUB PF 89.5/92			
	*Dimensions will vary for cranks equipped with crank boots. Consult the section titled "Crank Boot."									

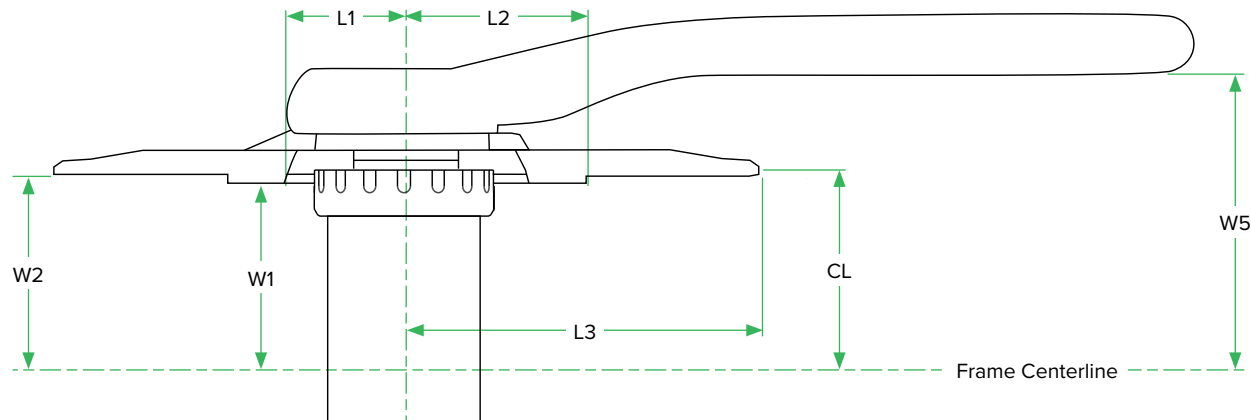

GX Eagle DUB

Non-Drive Frame Clearance

		W1	W2	W3	W4	W5	W6	W7*
1x12	X	25	35	65	85	105	130	190
	Y (non-BOOST & BOOST)	57	59.9	67.7	70.4	71.5	71.6	71.6
	Y (Eagle DUB 55 CL)	60	62.9	70.7	73.4	74.5	74.6	74.6
Q-factor : 169 (non-BOOST & BOOST) / 175 (Eagle DUB 55 CL)					Bottom Bracket Type(s): DUB BSA 73 : DUB BB30 : DUB PF30 : DUB PF 89.5/92			
*Dimensions will vary for cranks equipped with crank boots. Consult the Crank Boot Clearance Information page.								

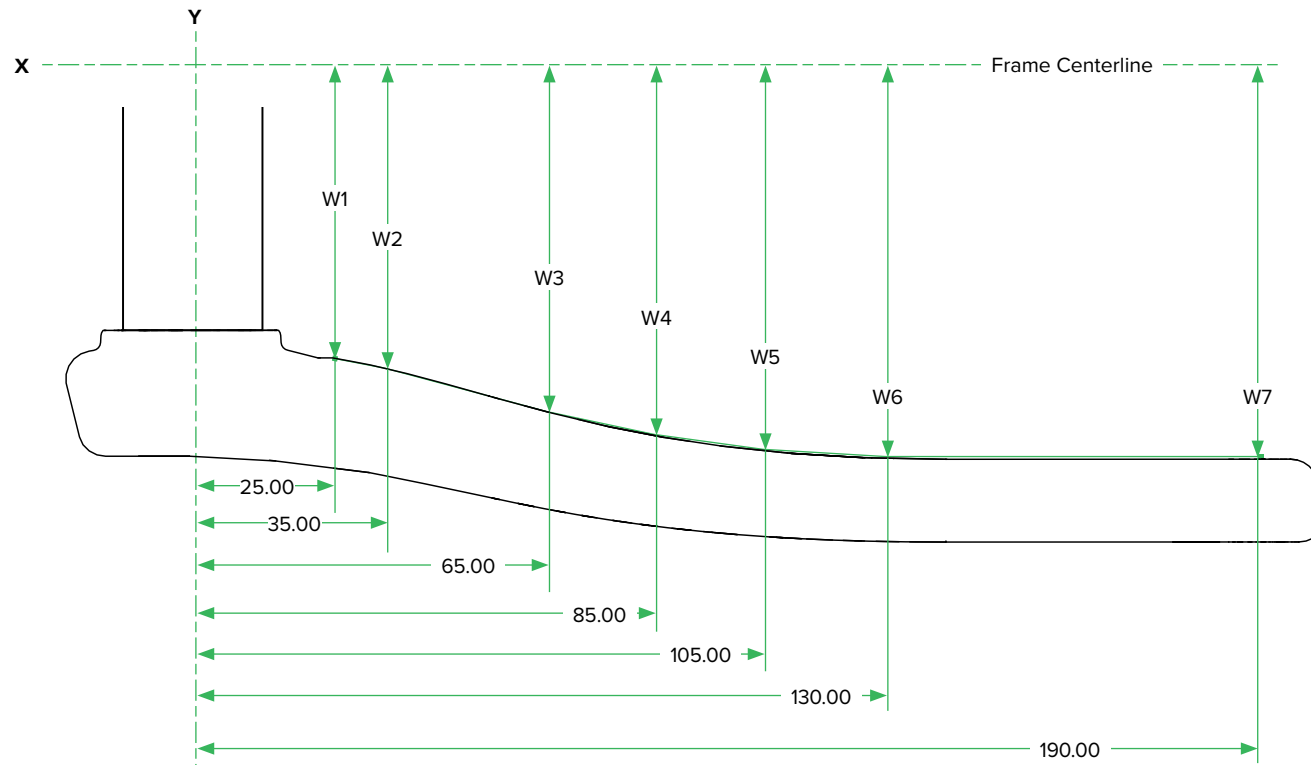

GX Eagle DUB SB+

Drive Side Frame Clearance

1x12	Chainring	L1	L2	L3	W1	W2	CL	W5*
	30T	28.9	31.4	64.3	57.9	54.7	56.5	76.2
	32T			68.3				
	34T			72.4				
Q-factor : 178		Bottom Bracket Type(s): DUB BSA 73 SB+ : DUB PF 92 SB+						
*Dimensions will vary for cranks equipped with crank boots. Consult the section titled "Crank Boot."								

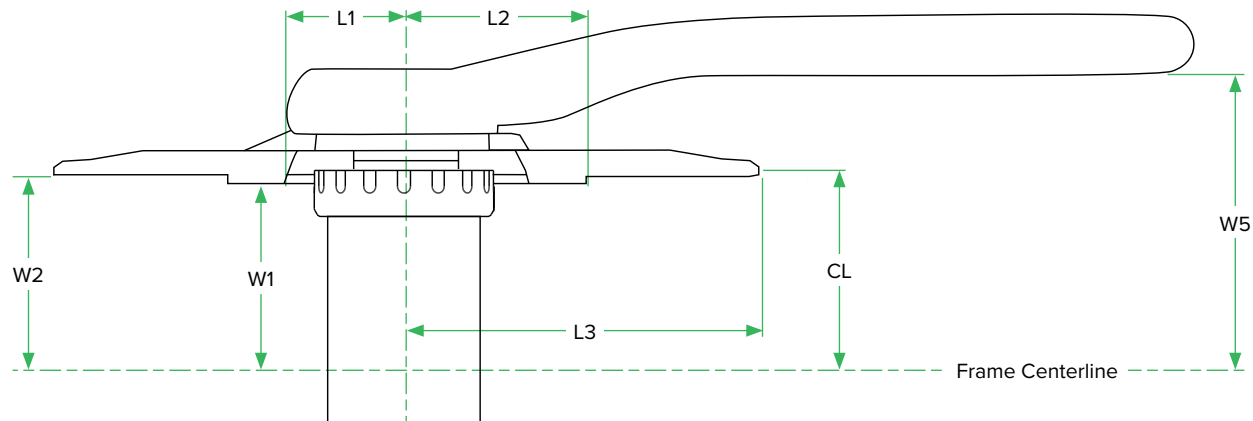

GX Eagle DUB SB+

Non-Drive Frame Clearance

		W1	W2	W3	W4	W5	W6	W7*
1x12	X	25	35	65	85	105	130	190
	Y	62.9	64.4	72.2	74.9	76	76.2	76.2
	Q-factor : 178		Bottom Bracket Type(s): DUB BSA 73 SB+ : DUB PF 92 SB+					
	*Dimensions will vary for cranks equipped with crank boots. Consult the Crank Boot Clearance Information page.							

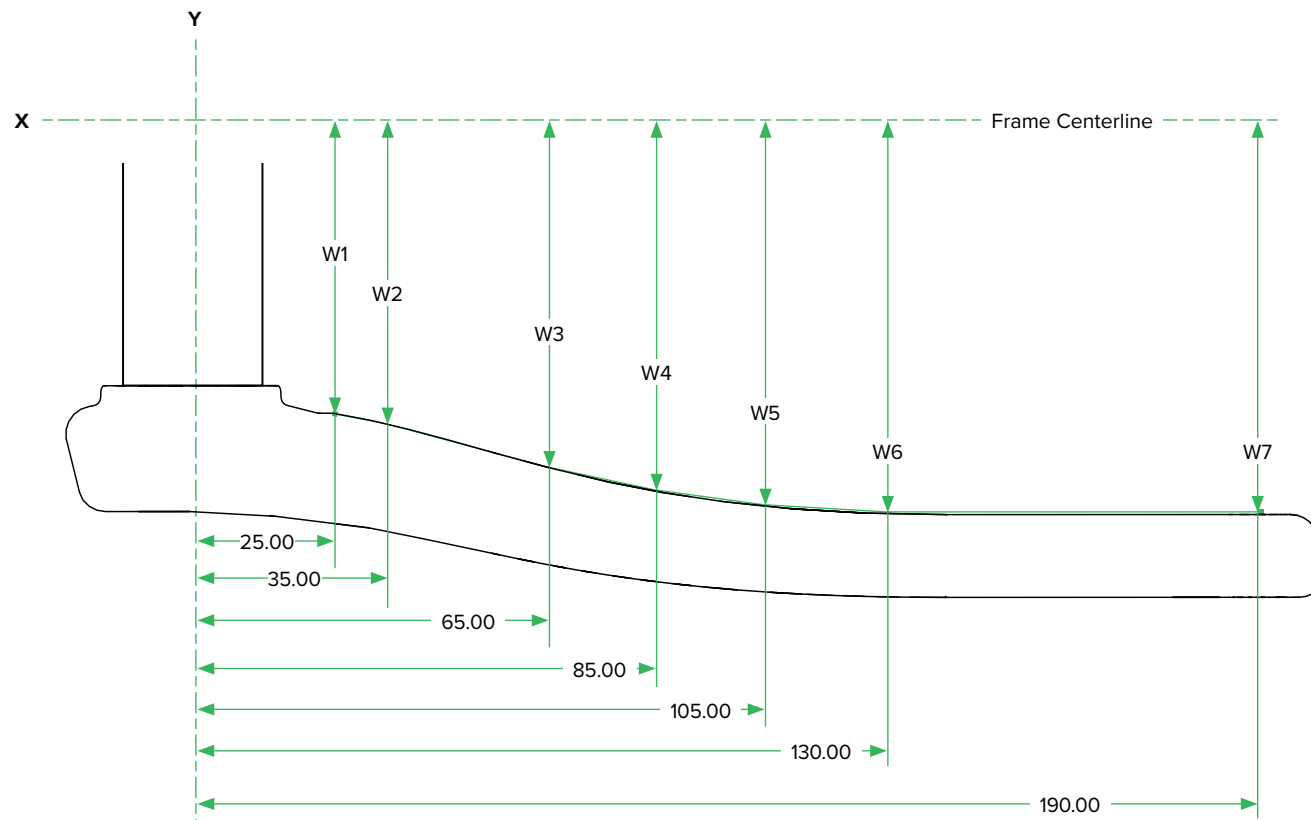

GX Eagle DUB - Fatbike

Drive Side Frame Clearance

1x12	Chainring		L1	L2	L3	W1	W2	CL	W5
	30T	4" Fatbike (170 OLD)	25.9	29.4	64.3	65.5	65	66.5	91.1
		5" Fatbike (190 OLD)	22.8	29		70	74.7	76.5	
Q-factor : 206				Bottom Bracket Type(s): DUB BSA 100 : DUB PF 121					

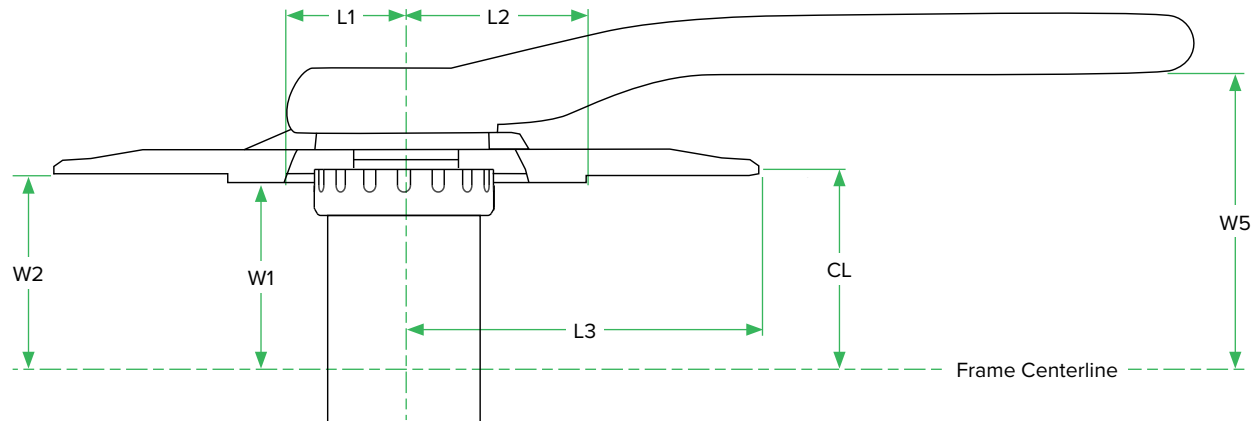

GX Eagle DUB - Fatbike

Non-Drive Frame Clearance

		W1	W2	W3	W4	W5	W6	W7
1x12	X	25	35	65	85	105	130	190
	Y	72.75	77.6	86.6	90.1	91.4	91.5	91.5
Q-factor : 206		Bottom Bracket Type(s): DUB BSA 100 : DUB PF 121						

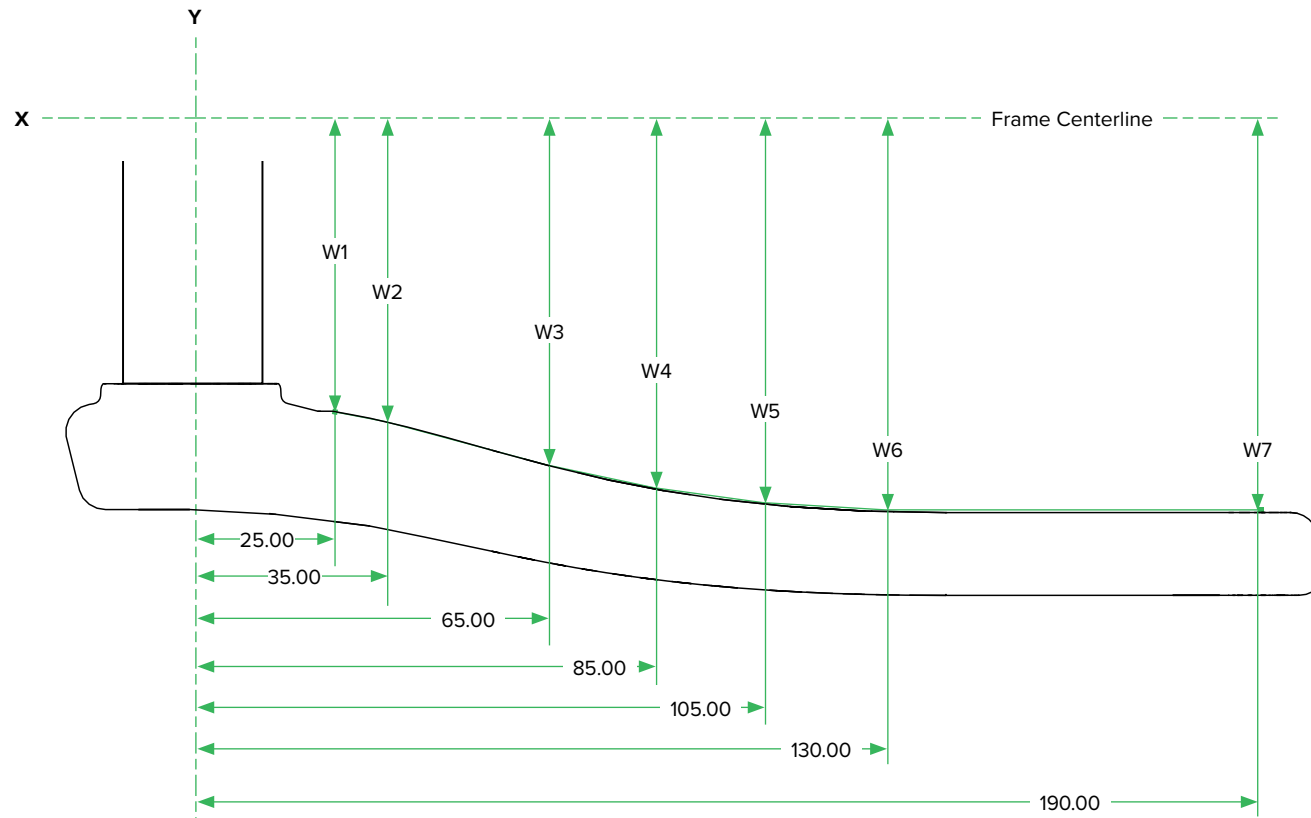

Descendant 7K Eagle DUB

Descendant 7K Eagle DUB

Drive Side Frame Clearance - BOOST and non-BOOST

Chainring		L1	L2	L3	W1	W2	CL	W5*
1x12	30T	non-BOOST	50.7	64.3	48 51 (BOOST Variant)	47.3 50.3 (BOOST Variant)	49 52 (BOOST Variant)	71.7
		BOOST	58.7					
	32T	non-BOOST	54.7	68.3				
		BOOST	55.2					
	34T	non-BOOST	58.7	72.3				
		BOOST	59.2					
Q-factor : 169			Bottom Bracket Type(s): DUB BSA 73 : DUB BB30 : DUB PF30 : DUB PF 89.5/92					
*Dimensions will vary for cranks equipped with crank boots. Consult the section titled "Crank Boot."								

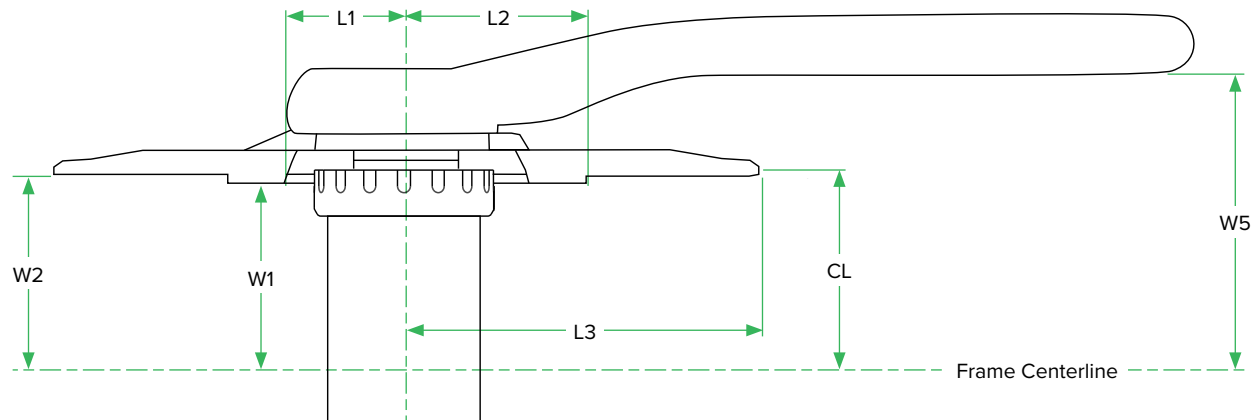

Descendant 7K Eagle DUB

Non-Drive Frame Clearance

		W1	W2	W3	W4	W5	W6	W7*
1x12	X	25	35	65	85	105	130	190
	Y	57	59.9	67.7	70.4	71.5	71.6	71.6
	Q-factor : 169		Bottom Bracket Type(s): DUB BSA 73 : DUB BB30 : DUB PF30 : DUB PF 89.5/92					
	*Dimensions will vary for cranks equipped with crank boots. Consult the section titled "Crank Boot."							

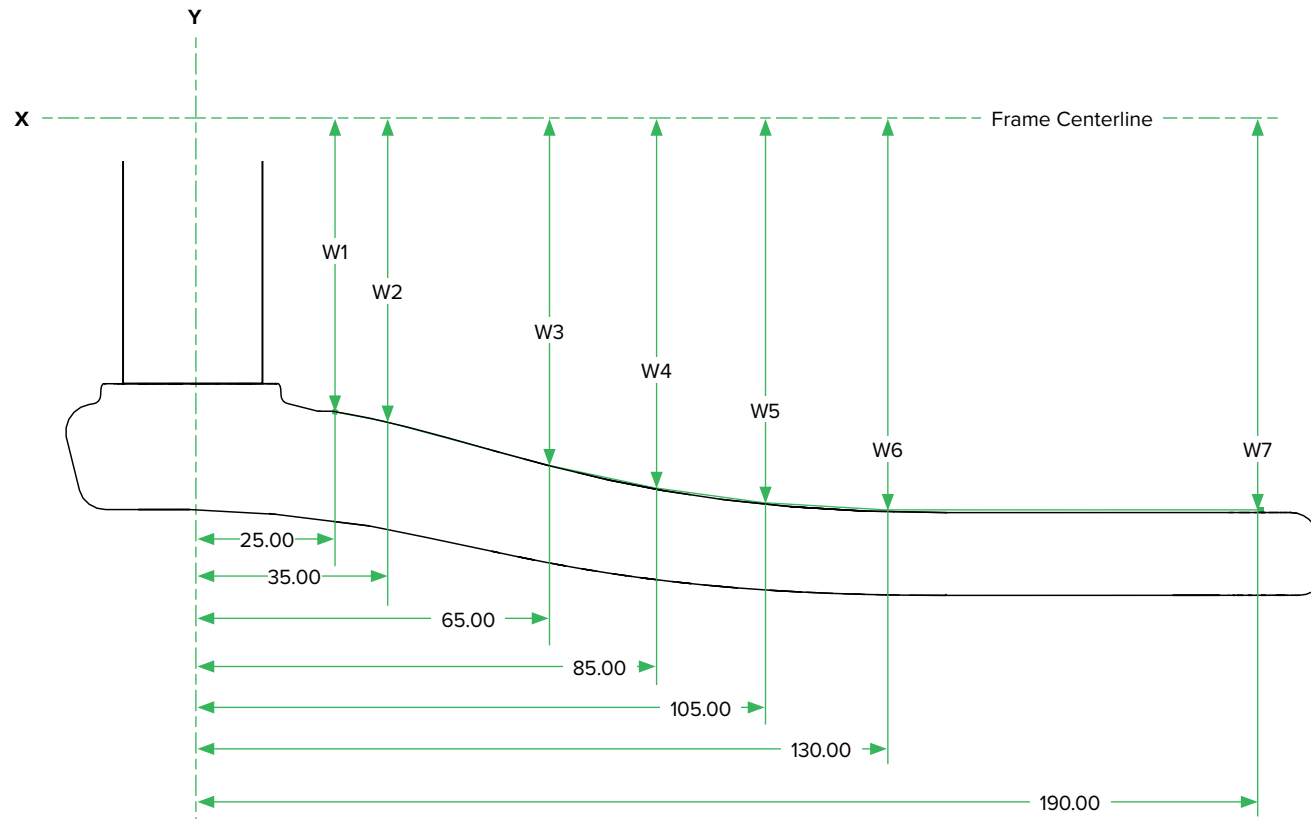

Descendant Eagle DUB SB+

Drive Side Frame Clearance

1x12	Chainring	L1	L2	L3	W1	W2	CL	W5
	30T	28.9	31.4	64.3	57.9	54.7	56.5	76.2
	32T			68.3				
	34T			72.4				
	30T Steel			63.8				
	32T Steel			67.8				
	34T Steel			71.9				
	Q-factor : 178			Bottom Bracket Type(s): DUB BSA 73 SB+ : DUB PF 92 SB+				

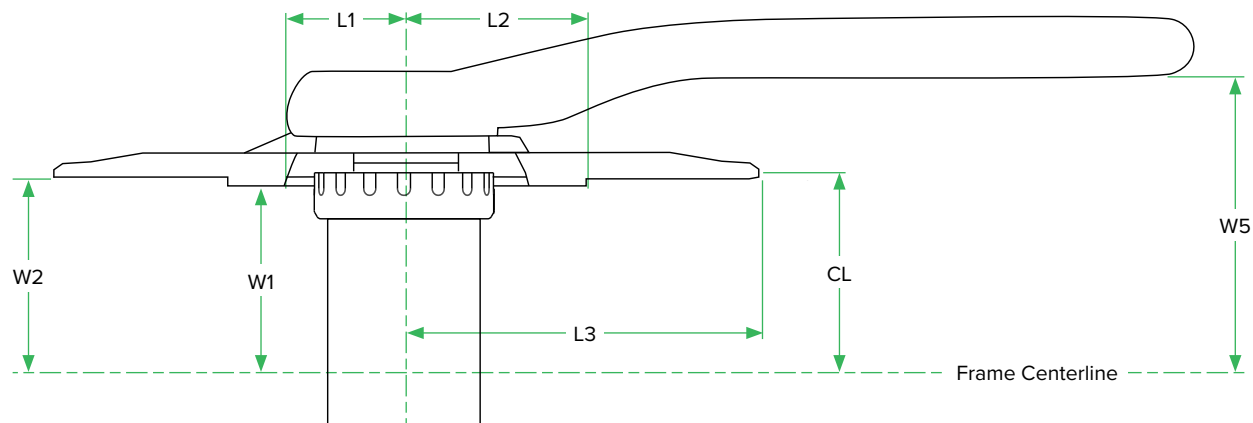

Descendant Eagle DUB SB+

Non-Drive Frame Clearance

		W1	W2	W3	W4	W5	W6	W7
1x12	X	25	35	65	85	105	130	190
	Y	62.9	64.4	72.2	74.9	76	76.2	76.2
Q-factor : 178		Bottom Bracket Type(s): DUB BSA 73 SB+ : DUB PF 92 SB+						

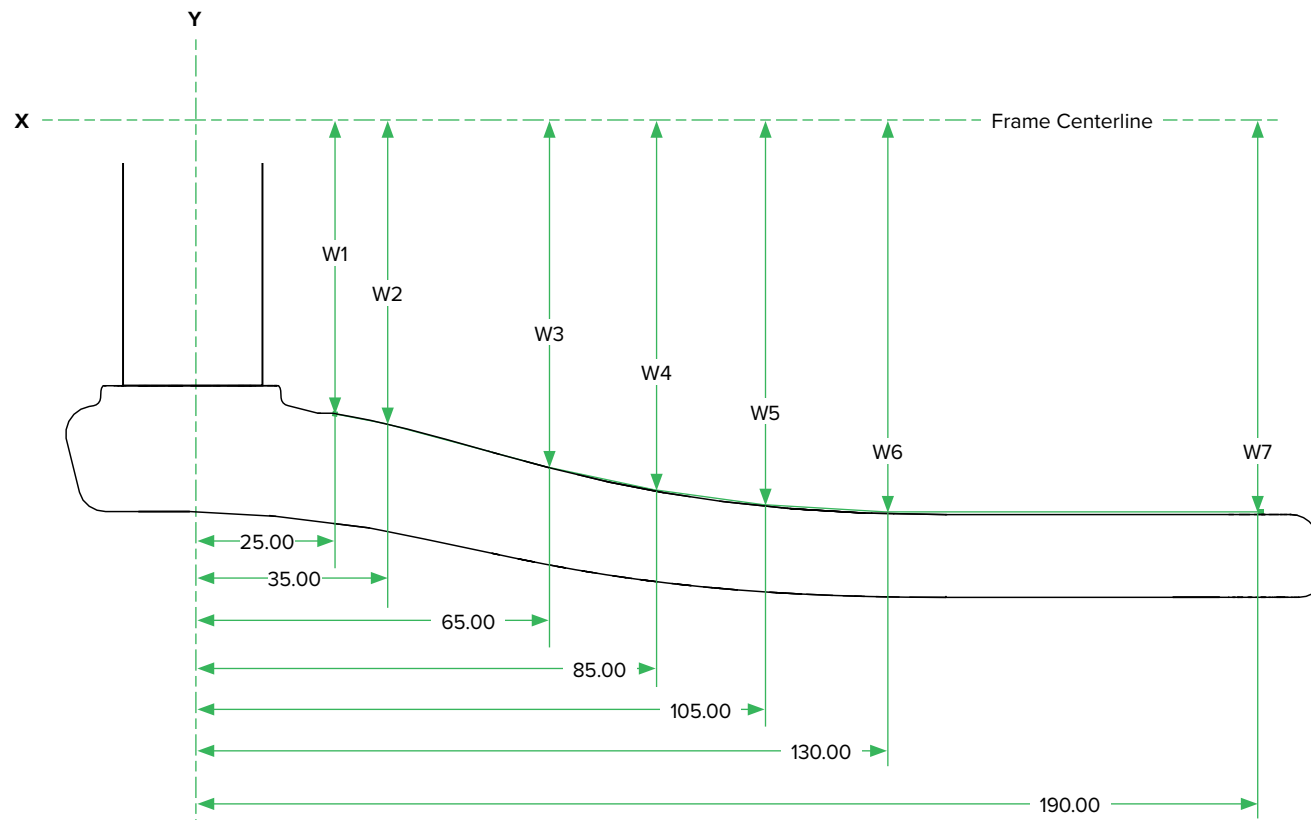

Descendant 6K Eagle DUB

Descendant 6K Eagle DUB

Drive Side Frame Clearance - BOOST and non-BOOST

1x12	Chainring		L1	L2	L3	W1	W2	CL	W5*
	30T	non-BOOST & Eagle DUB 55 CL	29.6	48.2	63.7	52.4	47.2	49	71.7
		BOOST		47.1					
	32T	non-BOOST & Eagle DUB 55 CL		50.9	67.8	52.8 (BOOST Variant)	50 (BOOST Variant)	52 (BOOST Variant)	71.7 (BOOST Variant)
		BOOST		51.2					
	34T	non-BOOST & Eagle DUB 55 CL		53.9	71.8	55.8 (Eagle DUB 55 CL)	53 (Eagle DUB 55 CL)	55 (Eagle DUB 55 CL)	74.7 (Eagle DUB 55 CL)
BOOST		54.2							
Q-factor : 169 (non-BOOST & BOOST) / 175 (Eagle DUB 55 CL)						Bottom Bracket Type(s): DUB BSA 73 : DUB BB30 : DUB PF30 : DUB PF 89.5/92			
*Dimensions will vary for cranks equipped with crank boots. Consult the section titled "Crank Boot."									

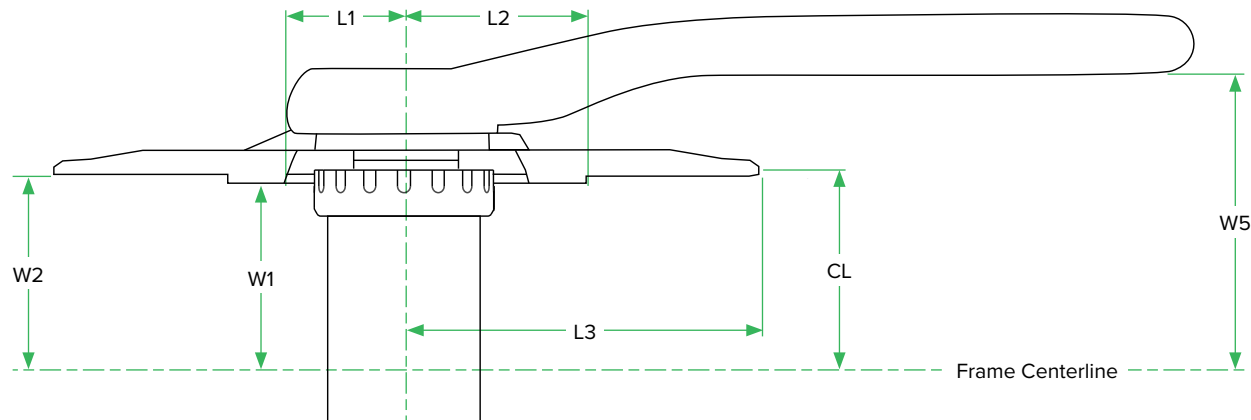

Descendant 6K Eagle DUB

Non-Drive Frame Clearance

		W1	W2	W3	W4	W5	W6	W7*
1x12	X	25	35	65	85	105	130	190
	Y (non-BOOST & BOOST)	57	59.9	67.7	70.4	71.5	71.6	71.6
	Y (Eagle DUB 55 CL)	60	62.9	70.7	73.4	74.5	74.6	74.6
Q-factor : 169 (non-BOOST & BOOST) / 175 (Eagle DUB 55 CL)					Bottom Bracket Type(s): DUB BSA 73 : DUB BB30 : DUB PF30 : DUB PF 89.5/92			
*Dimensions will vary for cranks equipped with crank boots. Consult the Crank Boot Clearance Information page.								

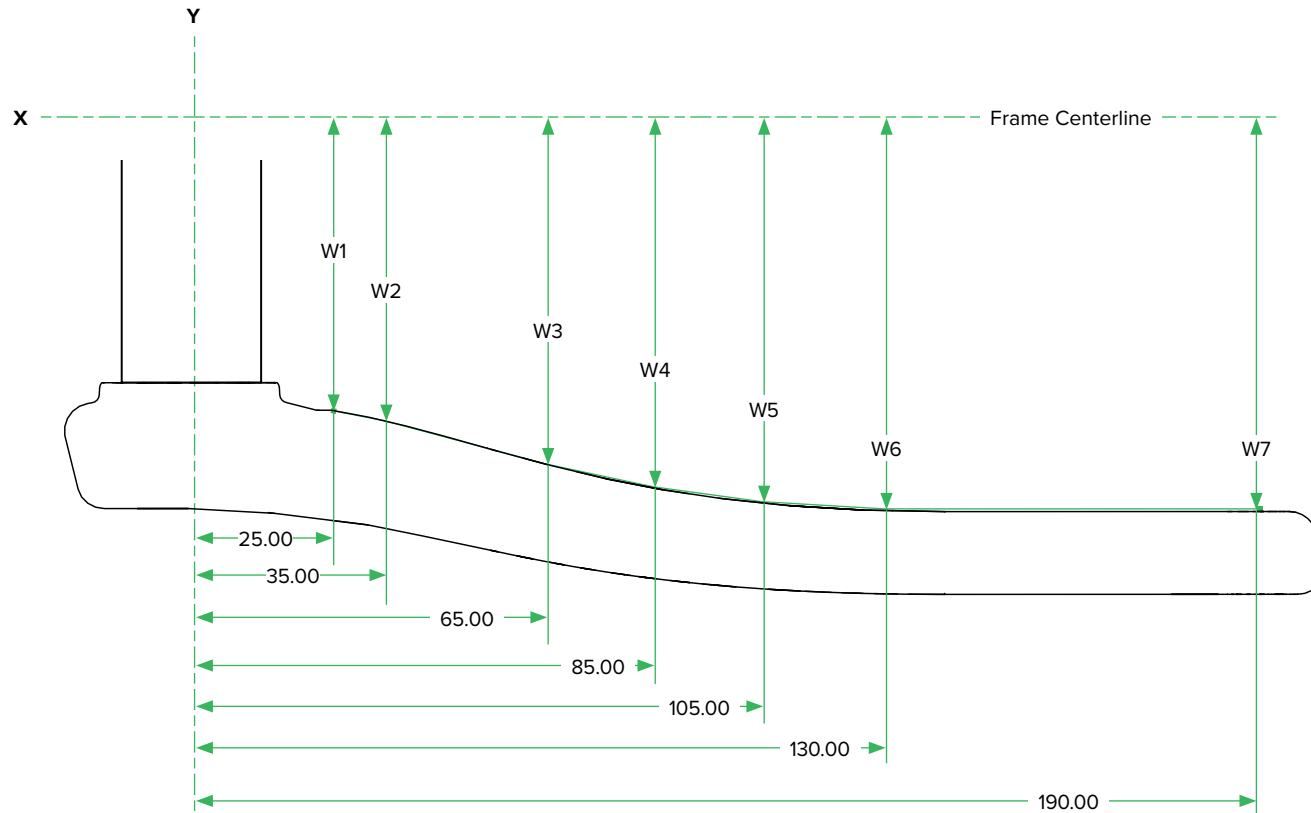

Descendant DH DUB

Descendant DH DUB

Drive Side Frame Clearance

1x7	Chainring	L1	L2	L3	W1	W2	CL	W5
	34 Steel	29.6	54	71.8	60	54.7	56.5	81
	34	31.5	58.7	72.3	55.5			
	36	27.2	29	76.4	54.7			
Q-factor : 187		Bottom Bracket Type(s): DUB BSA 83 : DUB PF 104.5/107						

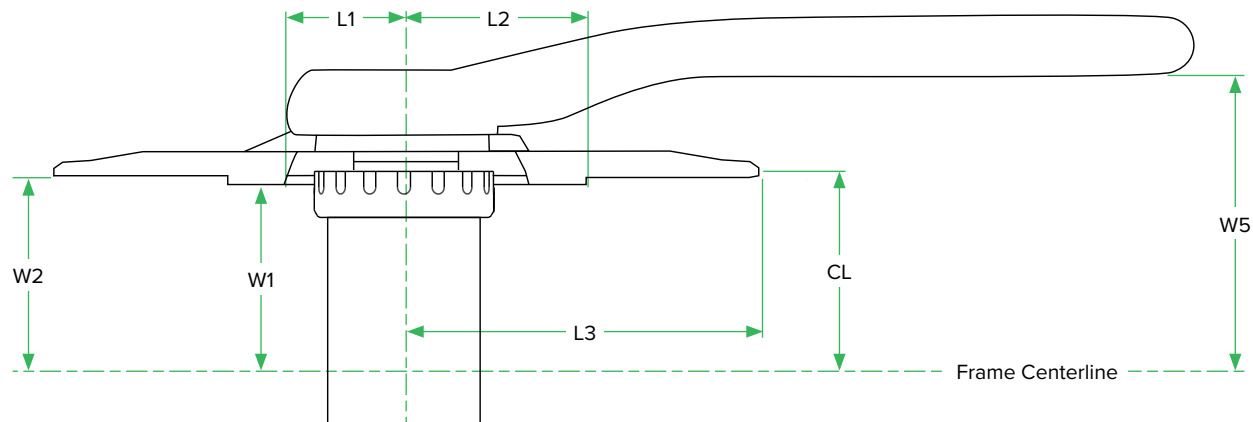

Descendant DH DUB

Non-Drive Frame Clearance

		W1	W2	W3	W4	W5	W6	W7
1x7	X	25	35	65	85	105	130	190
	Y	65.8	67.2	76.1	79.7	80.9	81	81
	Q-factor : 187		Bottom Bracket Type(s): DUB BSA 83 : DUB PF 104.5/107					

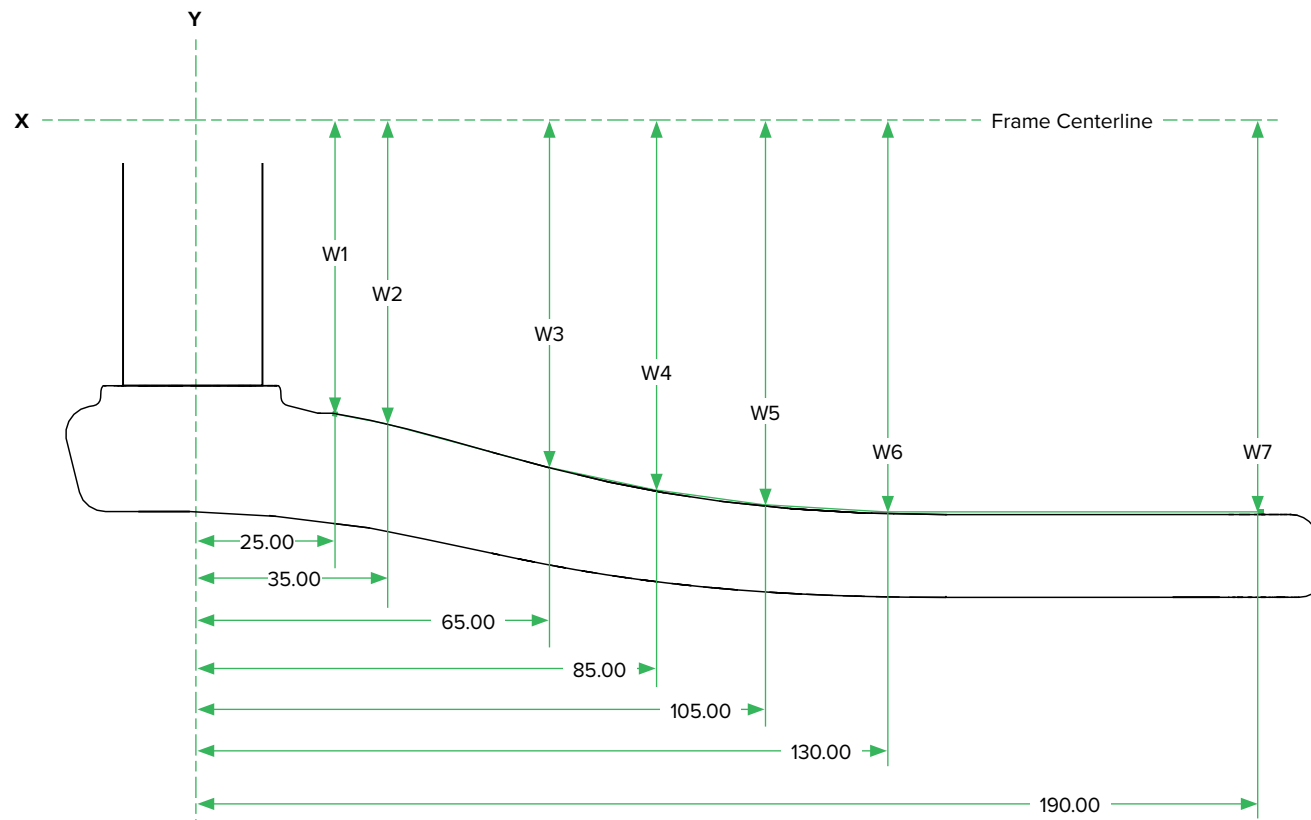

NX Eagle DUB/Stylo 7K Eagle DUB

NX Eagle DUB/Stylo 7K Eagle DUB

Drive Side Frame Clearance - BOOST and non-BOOST

	Chainring		L1	L2	L3	W1	W2	CL	W5*	
1x12	30T	non-BOOST	31.5	50.7	64.3	48 51 (BOOST Variant)	47.3 50 (BOOST Variant)	49 52 (BOOST Variant)	73.5	
		BOOST		58.7					73.5 (BOOST Variant)	
	32T	non-BOOST		54.7	68.3				76.5 (Eagle DUB 55 CL)	
		BOOST		55.2						
	34T	non-BOOST		58.7	72.3					
		BOOST		59.2						
Q-factor : 172 (non-BOOST & BOOST) / 178 (Eagle DUB 55 CL)				Bottom Bracket Type(s): DUB BSA 73 : DUB BB30 : DUB PF30 : DUB PF 89.5/92						
*Dimensions will vary for cranks equipped with crank boots. Consult the section titled "Crank Boot."										

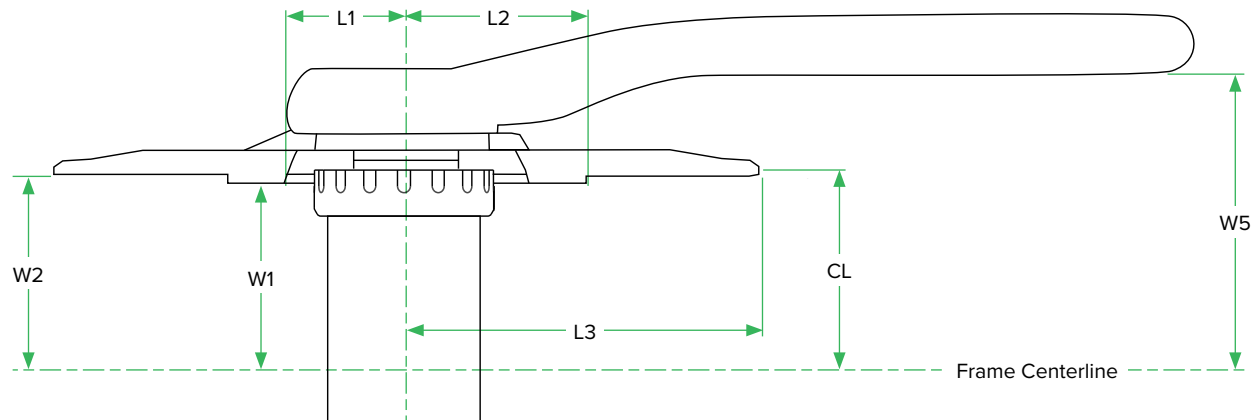

NX Eagle DUB/Stylo 7K Eagle DUB

Non-Drive Frame Clearance

		W1	W2	W3	W4	W5	W6	W7*
1x12	X	25	35	65	85	105	130	190
	Y (non-BOOST & BOOST)	58.2	59.7	67.5	71.3	73.1	73.4	73.4
	Y (Eagle DUB 55 CL)	61.2	62.7	70.5	71.3	76.1	76.4	76.4
Q-factor : 169 (non-BOOST & BOOST) / 175 (Eagle DUB 55 CL)					Bottom Bracket Type(s): DUB BSA 73 : DUB BB30 : DUB PF30 : DUB PF 89.5/92			
*Dimensions will vary for cranks equipped with crank boots. Consult the Crank Boot Clearance Information page.								

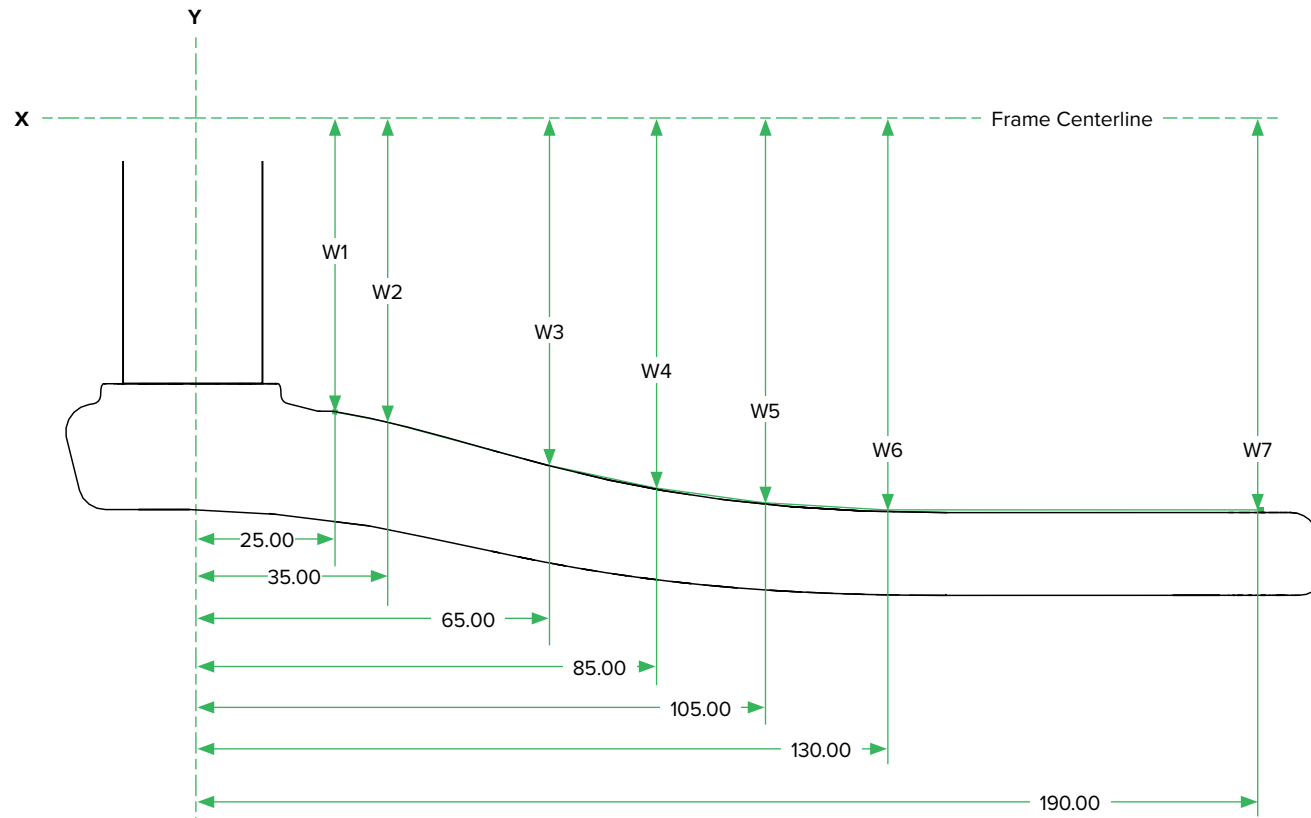

NX Eagle DUB/Stylo 7K Eagle DUB - Fat 4

Drive Side Frame Clearance

1x12	Chainring		L1	L2	L3	W1	W2	CL	W5
	30T	4" Fatbike (170 OLD)	25.9	29.4	64.3	69.7	64.7	66.5	91
Q-factor : 207.5				Bottom Bracket Type(s): DUB BSA 100 : DUB PF 121					

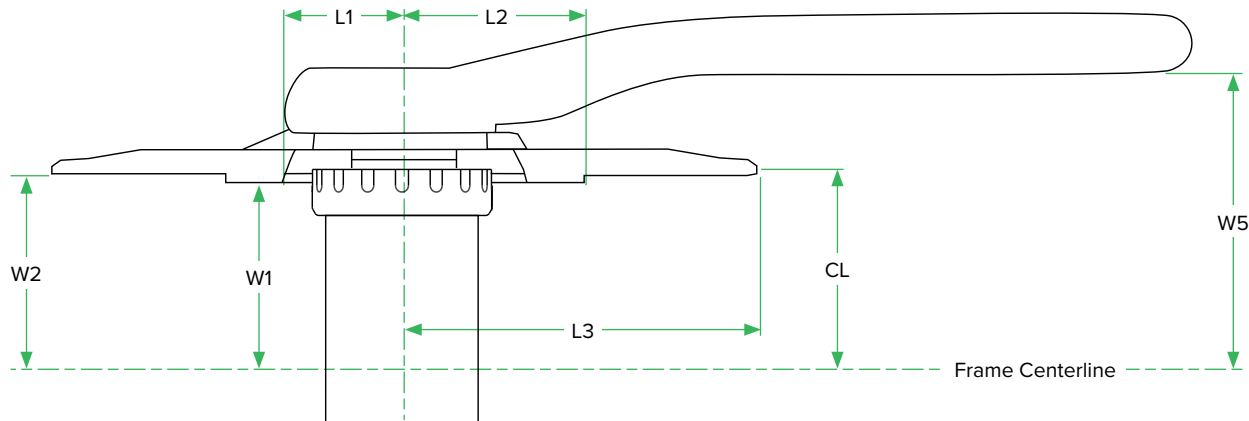

NX Eagle DUB/Stylo 7K Eagle DUB - Fat 4

Non-Drive Frame Clearance

		W1	W2	W3	W4	W5	W6	W7
1x12	X	25	35	65	85	105	130	190
	Y	76.2	77.7	85.5	89.3	91.1	91.4	91.4
	Q-factor : 206		Bottom Bracket Type(s): DUB BSA 100 : DUB PF 121					

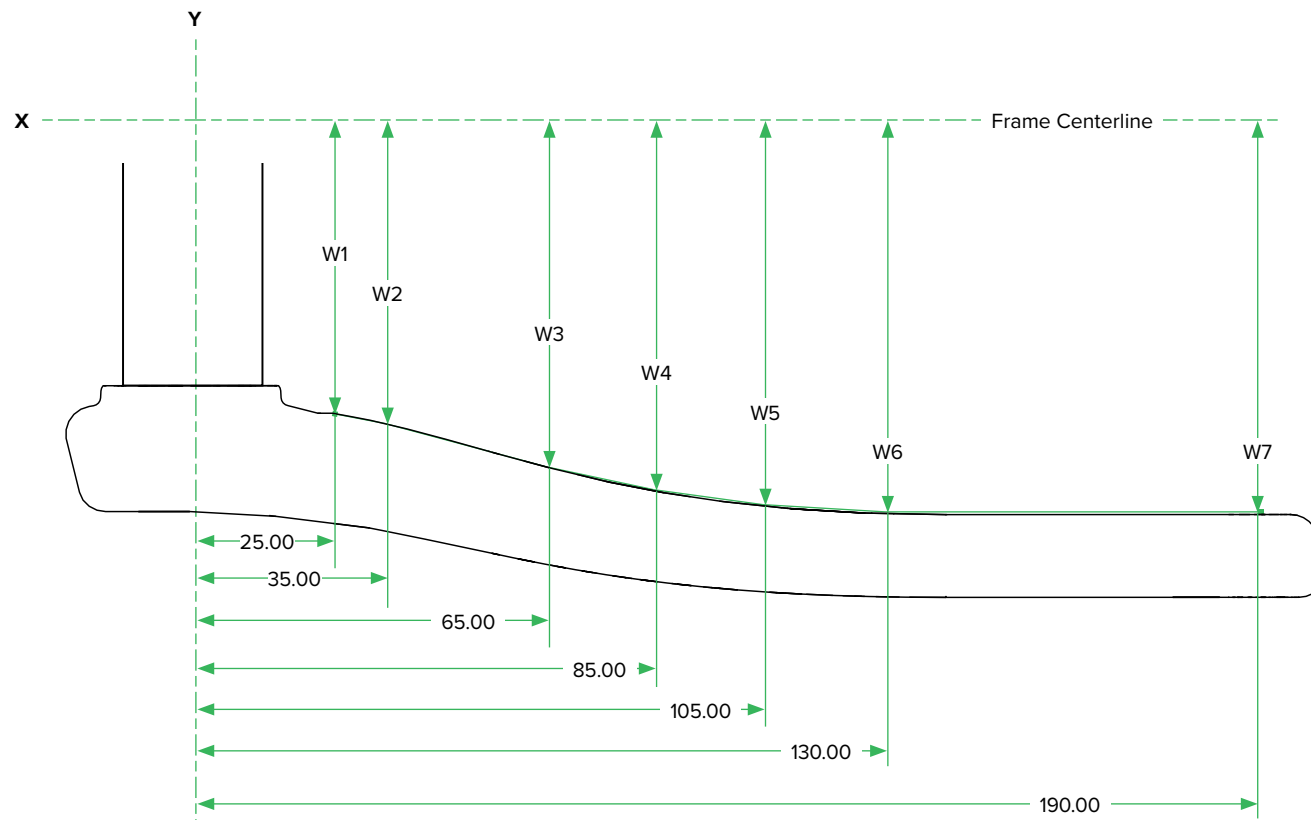

NX Eagle DUB/Stylo 6K Eagle DUB

NX Eagle DUB/Stylo 6K Eagle DUB

Drive Side Frame Clearance

	Chainring		L1	L2	L3	W1	W2	CL	W5*		
1x12	30T	non-BOOST	29.6	46.7	63.7	52.4 52.8 (BOOST Variant)	47.2 50 (BOOST Variant)	49 52 (BOOST Variant)	73.5		
		BOOST		47.1					73.5 (BOOST Variant)		
	32T	non-BOOST		50.9	67.8				71.8	76.5 (Eagle DUB 55 CL)	
		BOOST		51.2							
	34T	non-BOOST		53.9							
		BOOST		54.2							
Q-factor : 172 (non-BOOST & BOOST) / 178 (Eagle DUB 55 CL)			Bottom Bracket Type(s): DUB BSA 73 : DUB BB30 : DUB PF30 : DUB PF 89.5/92								
*Dimensions will vary for cranks equipped with crank boots. Consult the section titled "Crank Boot."											

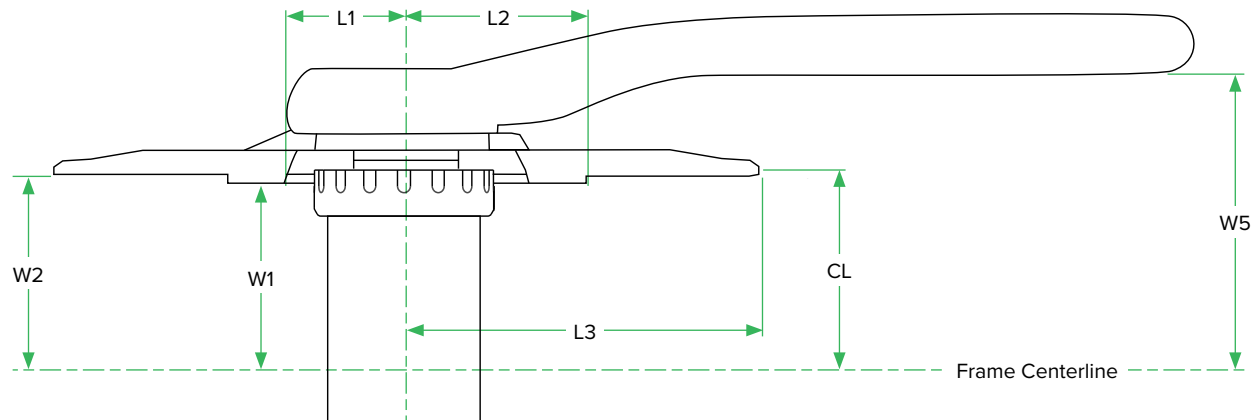

NX Eagle DUB/Stylo 6K Eagle DUB

Non-Drive Frame Clearance

		W1	W2	W3	W4	W5	W6	W7*
1x12	X	25	35	65	85	105	130	190
	Y (non-BOOST & BOOST)	58.2	59.7	67.5	71.3	73.1	73.4	73.4
	Y (Eagle DUB 55 CL)	61.2	62.7	70.5	71.3	76.1	76.4	76.4
Q-factor : 172 (non-BOOST & BOOST) / 178 (Eagle DUB 55 CL)					Bottom Bracket Type(s): DUB BSA 73 : DUB BB30 : DUB PF30 : DUB PF 89.5/92			
*Dimensions will vary for cranks equipped with crank boots. Consult the Crank Boot Clearance Information page.								

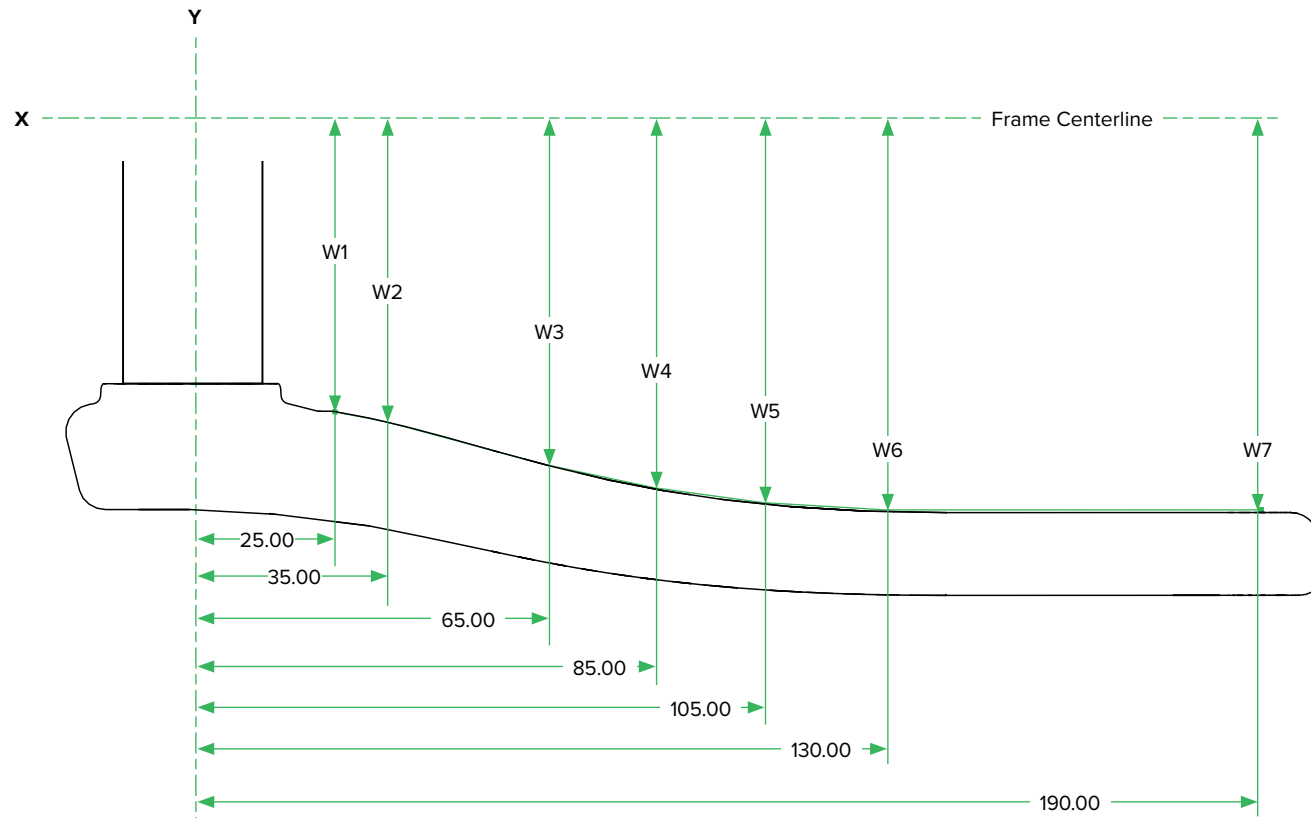

NX Eagle DUB/Stylo 6K Eagle DUB - Fat 4

Drive Side Frame Clearance

1x12	Chainring		L1	L2	L3	W1	W2	CL	W5
	30T	4" Fatbike (170 OLD)	29.6	46.7	63.7	69.8	64.7	66.5	91
Q-factor : 207.5				Bottom Bracket Type(s): DUB BSA 100 : DUB PF 121					

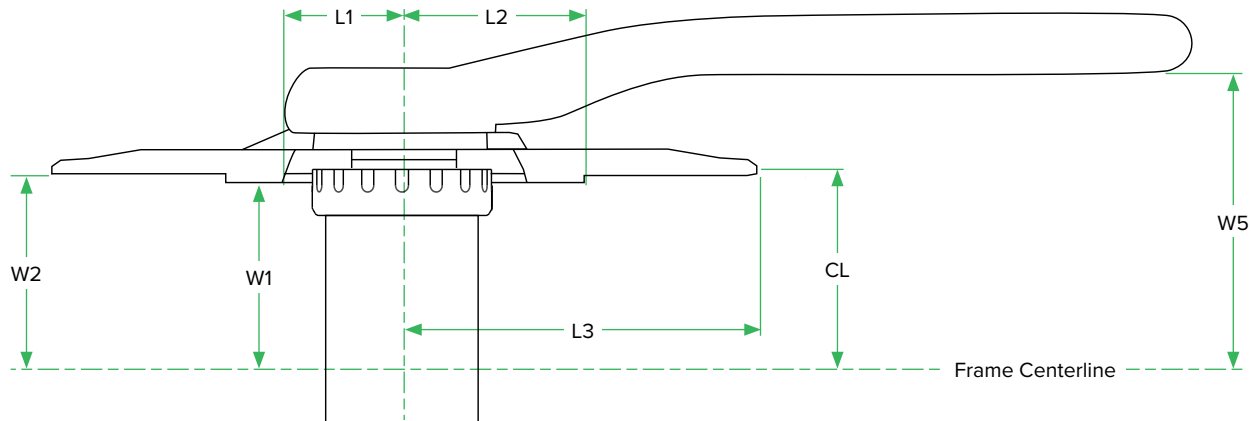

NX Eagle DUB/Stylo 6K Eagle DUB - Fat 4

Non-Drive Frame Clearance

		W1	W2	W3	W4	W5	W6	W7
1x12	X	25	35	65	85	105	130	190
	Y	76.2	77.7	85.5	89.3	91.1	91.4	91.4
	Q-factor : 207.5		Bottom Bracket Type(s): DUB BSA 100 : DUB PF 121					

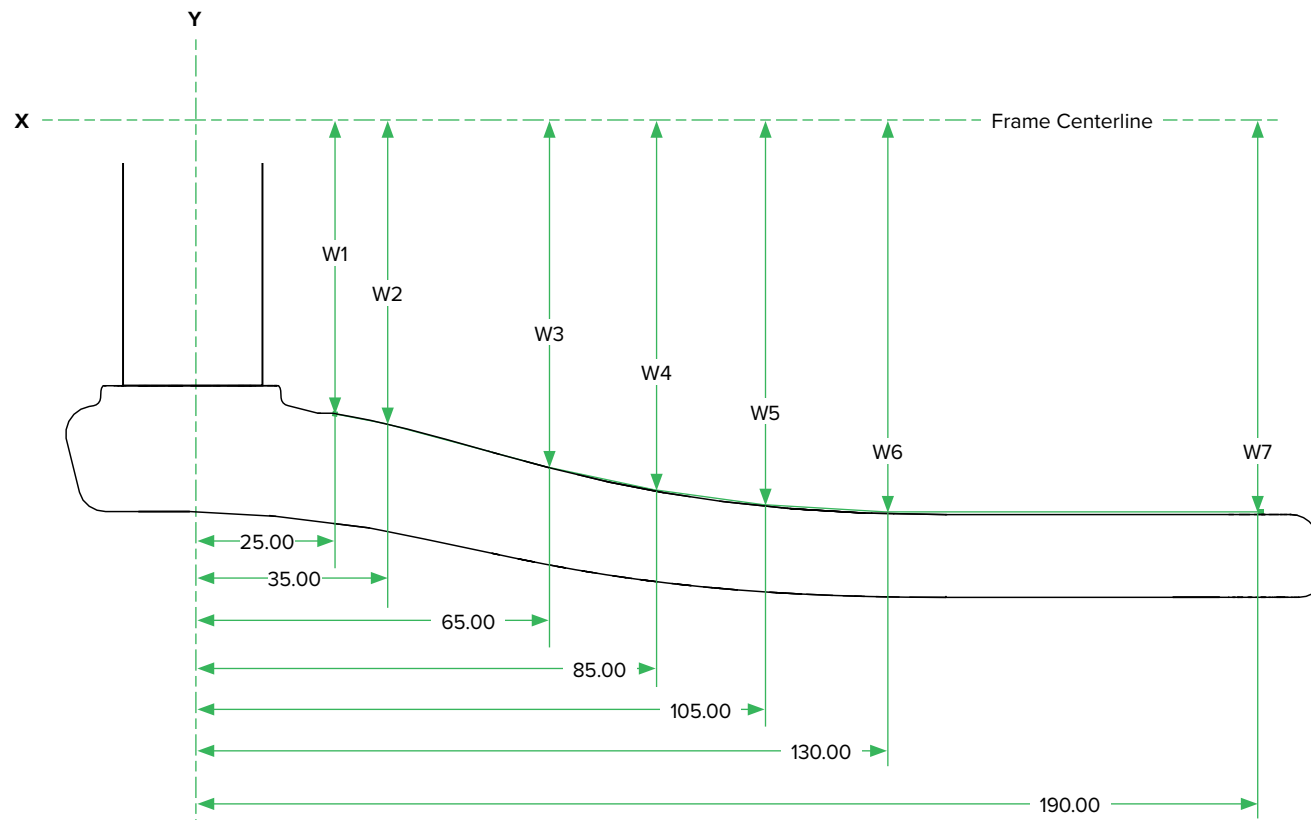

NX Eagle DUB - Fat 5

Drive Side Frame Clearance

1x12	Chainring		L1	L2	L3	W1	W2	CL	W5
	30T	5" Fatbike (190 OLD)	22.8	29	64.3	70	74.7	76.5	91
Q-factor : 207.5				Bottom Bracket Type(s): DUB BSA 100 : DUB PF 121					

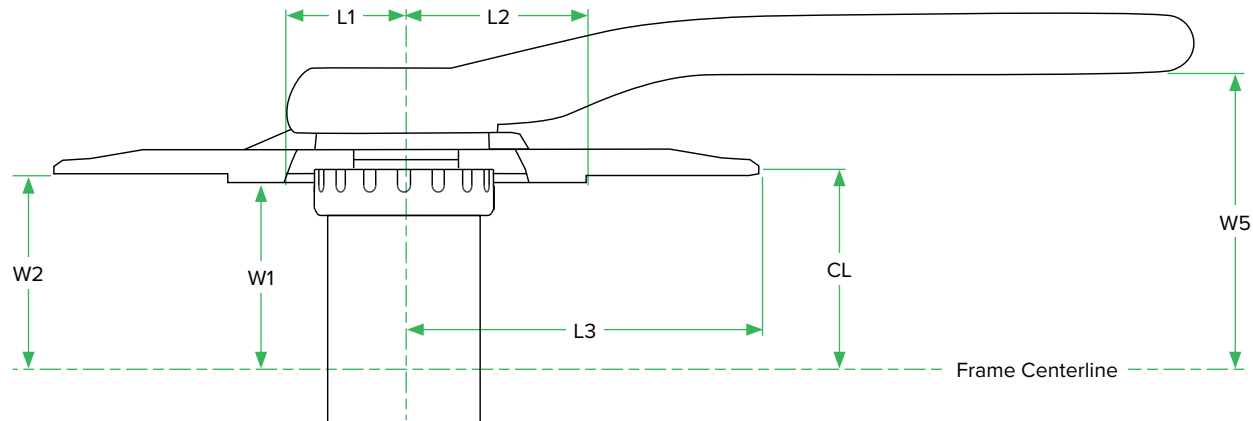

NX Eagle DUB - Fat 5

Non-Drive Frame Clearance

		W1	W2	W3	W4	W5	W6	W7
1x12	X	25	35	65	85	105	130	190
	Y	76.2	77.7	85.5	89.3	91.1	91.4	91.4
	Q-factor : 207.5		Bottom Bracket Type(s): DUB BSA 100 : DUB PF 121					

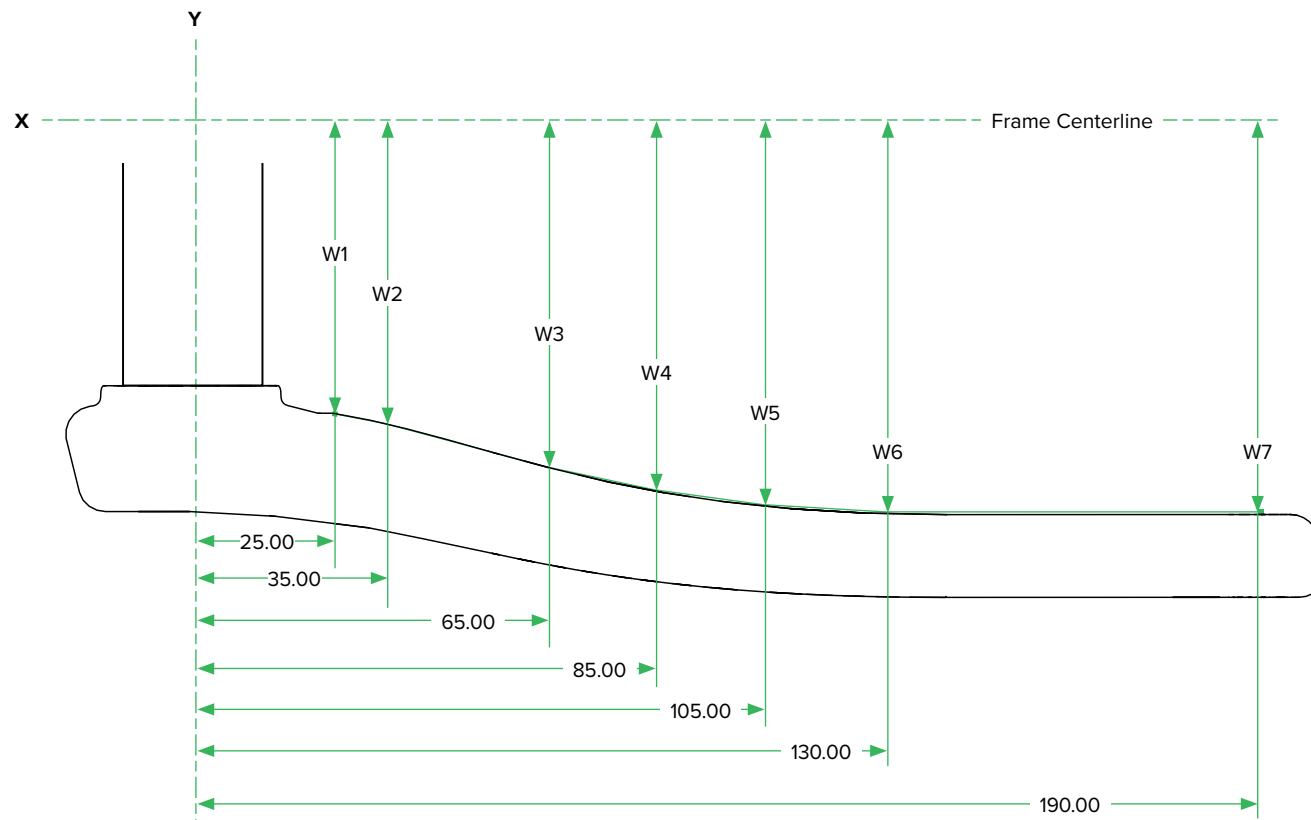

SX Eagle DUB/X1-1000 DUB

SX Eagle DUB/X1-1000 DUB

Drive Side Frame Clearance - BOOST and non-BOOST

1x12	Chainring		L1	L2	L3	L5	W1	W2	CL	W5*
	30T	non-BOOST & Eagle DUB 55 CL	29.6	46.7	63.7	192	52.4	47.2	49	73.5
		BOOST		47.1						
	32T	non-BOOST & Eagle DUB 55 CL		50.9	67.8		52.8 (BOOST Variant)	50 (BOOST Variant)	52 (BOOST Variant)	73.5 (BOOST Variant)
		BOOST		51.2						
34T	non-BOOST & Eagle DUB 55 CL	53.9		71.8	55.8 (Eagle DUB 55 CL)		53 (Eagle DUB 55 CL)	55 (Eagle DUB 55 CL)	76.5 (Eagle DUB 55 CL)	
	BOOST	54.2								
Q-factor : 173 (non-BOOST & BOOST) / 179 (Eagle DUB 55 CL)						Bottom Bracket Type(s): DUB BSA 73 : DUB BB30 : DUB PF30 : DUB PF 89.5/92				
*Dimensions will vary for cranks equipped with crank boots. Consult the section titled "Crank Boot."										

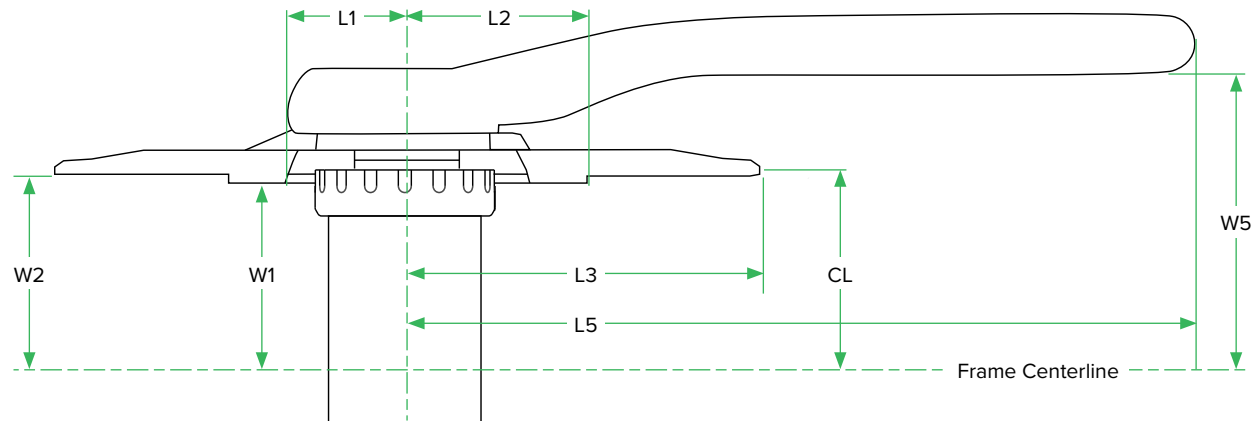

SX Eagle DUB/X1-1000 DUB

Non-Drive Frame Clearance

		W1	W2	W3	W4	W5	W6	W7*
1x12	X	25	35	65	85	105	130	190
	Y (non-BOOST & BOOST)	61	61.5	67	70.6	71.96	72.5	72.5
	Y (Eagle DUB 55 CL)	64	64.5	70	73.6	74.96	75.5	75.5
Q-factor : 173 (non-BOOST & BOOST) / 179 (Eagle DUB 55 CL)					Bottom Bracket Type(s): DUB BSA 73 : DUB BB30 : DUB PF30 : DUB PF 89.5/92			
*Dimensions will vary for cranks equipped with crank boots. Consult the section titled "Crank Boot."								

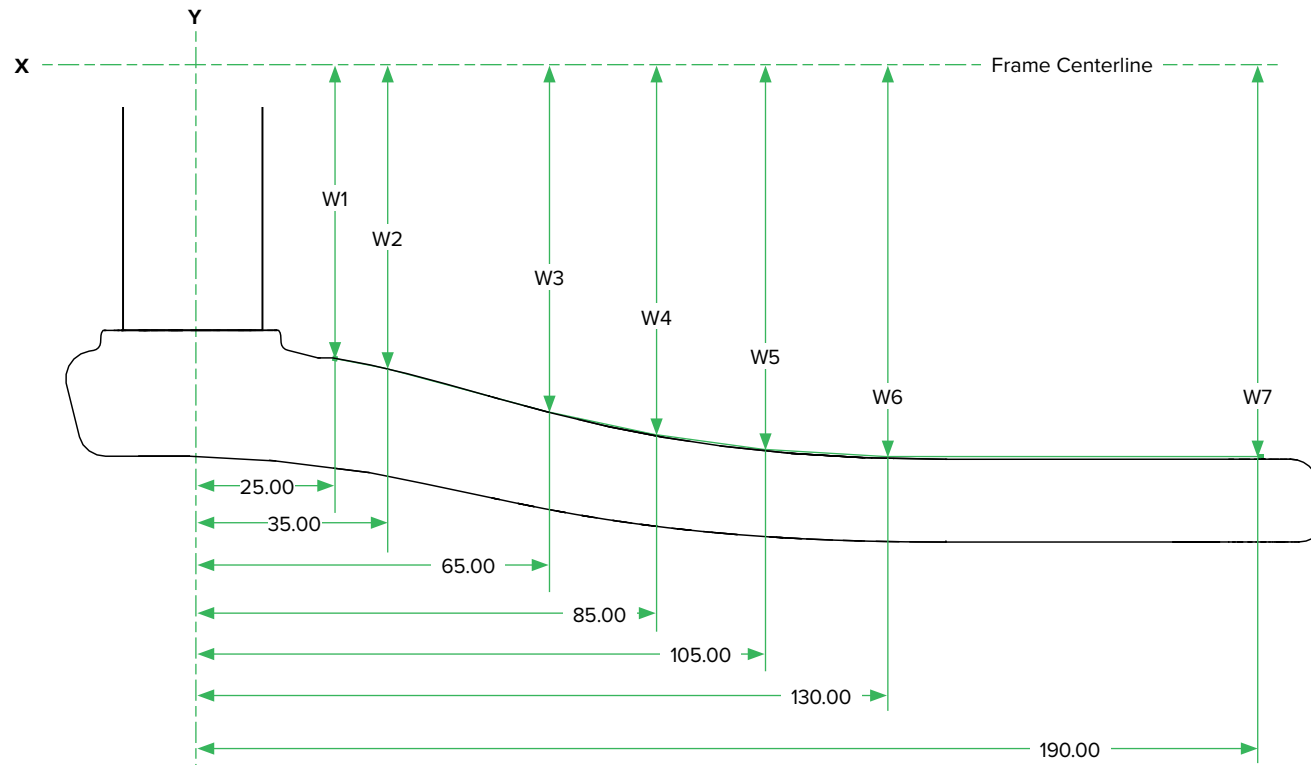

X1 1000 Eagle DUB Fat 5

X1 1000 Eagle DUB Fat 5

Drive Side Frame Clearance

	Chainring	L1	L2	L3	L5	W1	W2	CL	W5*
1x12	30T	27.2	29.8	64.2	192	70	75.5	76.5	91
	Q-factor : 208.5		Bottom Bracket Type(s): DUB BSA 100 : DUB PF 121						
	*Dimensions will vary for cranks equipped with crank boots. Consult the section titled "Crank Boot."								

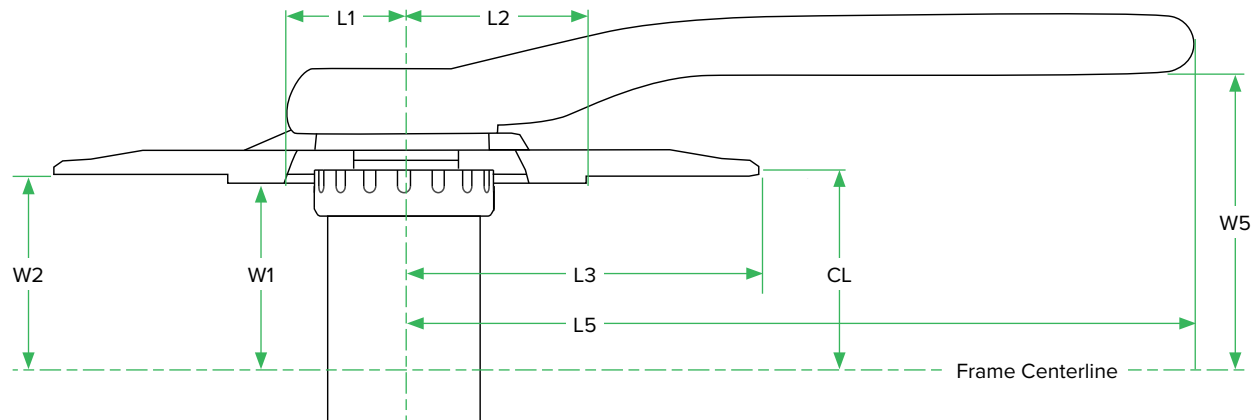

X1 1000 Eagle DUB Fat 5

Non-Drive Frame Clearance

		W1	W2	W3	W4	W5	W6	W7*
1x12	X	25	35	65	85	105	130	190
	Y	76.2	77.7	85.5	89.3	91.1	91.4	91.4
	Q-factor : 208.5		Bottom Bracket Type(s): DUB BSA 100 : DUB PF 121					
*Dimensions will vary for cranks equipped with crank boots. Consult the section titled "Crank Boot."								

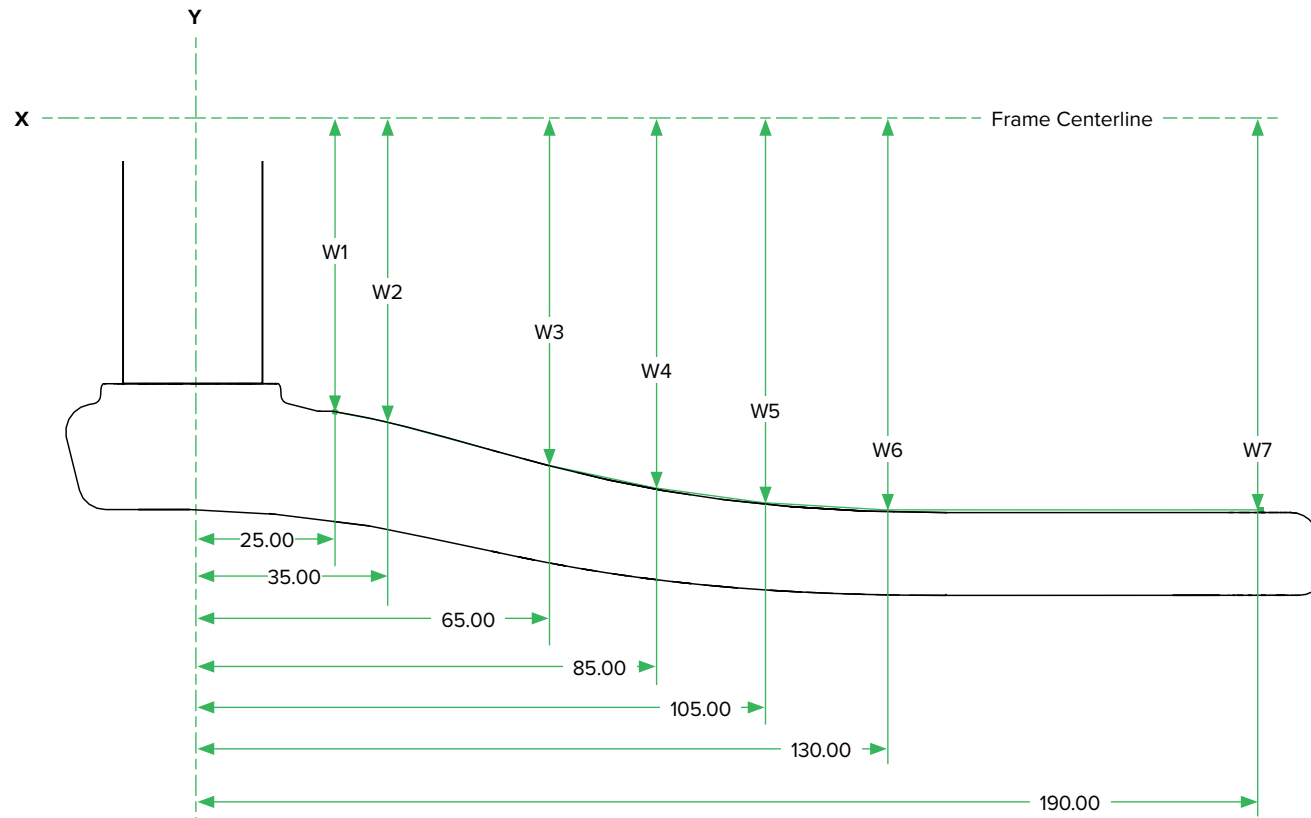

1x11 & 1x7 Cranksets

NX

Crankset Frame Clearance

	Chainring	L1	L2	L3	L4	L5	W1	W2	W3	W5	W6	CL
1x11	28	-	31.5	59.7	-	192	45.5	46.5	55.5	72	72	49
	30			64.5	69.5							
	32			68.5	73.5							
	34	23	40	72.5	77.5							
	36			76.5	81.5							
	38			80.5	85.5							
Q-factor : 169							Bottom Bracket Type(s): GXP : BB30 : PF30 : PFGXP					

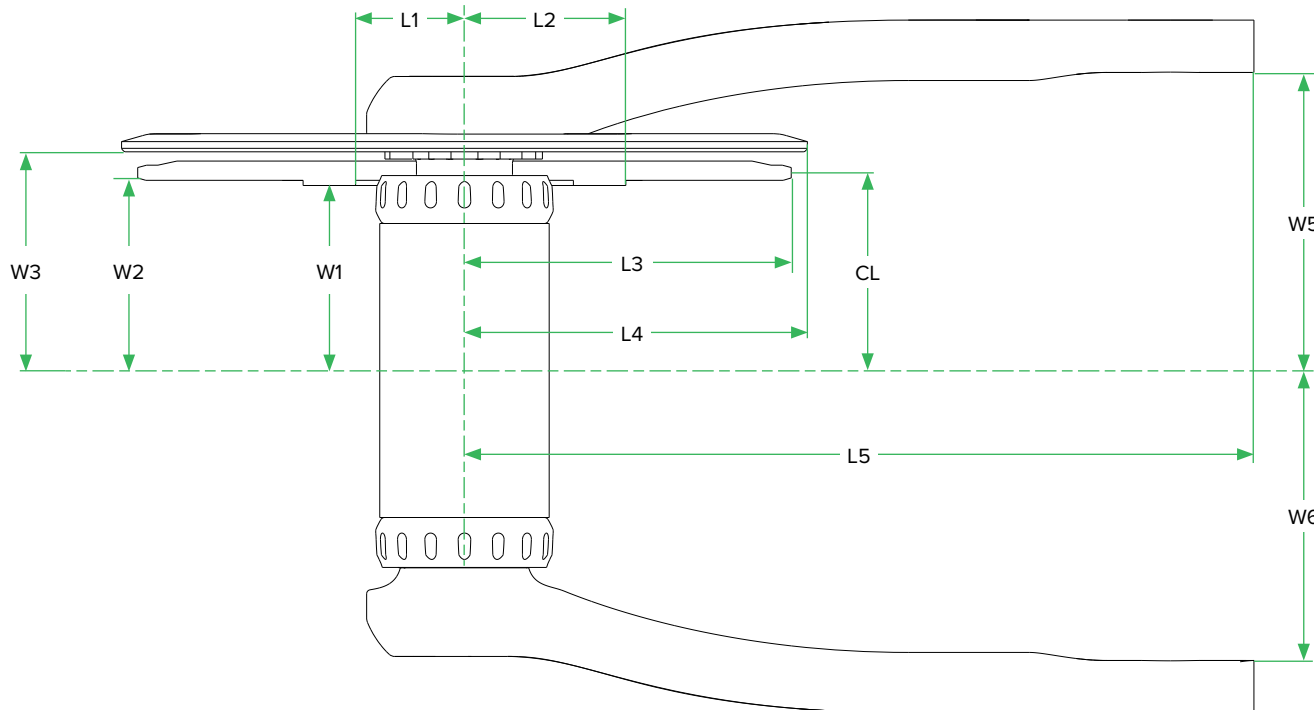

NX - BOOST 148 Compatible

Crankset Frame Clearance

	Chainring	L1	L2	L3	L4	L5	W1	W2	W3	W5	W6	CL
1x11	30	23	40	64.5	69.5	192	49	50	57.3	72	72	52
	32			68.5	73.5							
	34			72.5	77.5							
	36			76.5	81.5							
	38			80.5	85.5							
Q-factor : 169							Bottom Bracket Type(s): GXP : BB30 : PF30 : PFGXP					

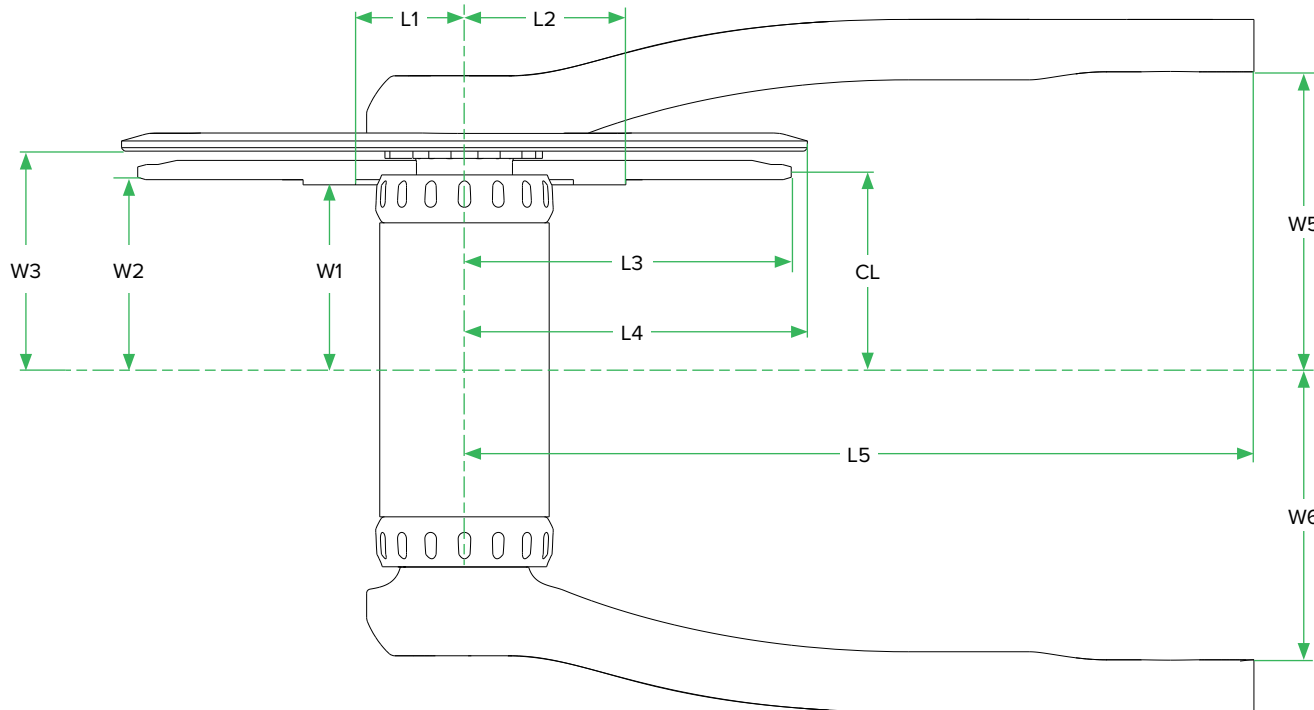

NX Power Spline

Crankset Frame Clearance

	Chainring	L1	L2	L3	L5	W1	W2	W5	W6	CL
1x11	28	-	31.5	59.7	192	46	47.2	73.5	73.5	49
	30	34.5	39	64	192	46	47.5	73.5	73.5	49
	32			68						
Q-factor : 172						Bottom Bracket Type(s): Power Spline 118/73				

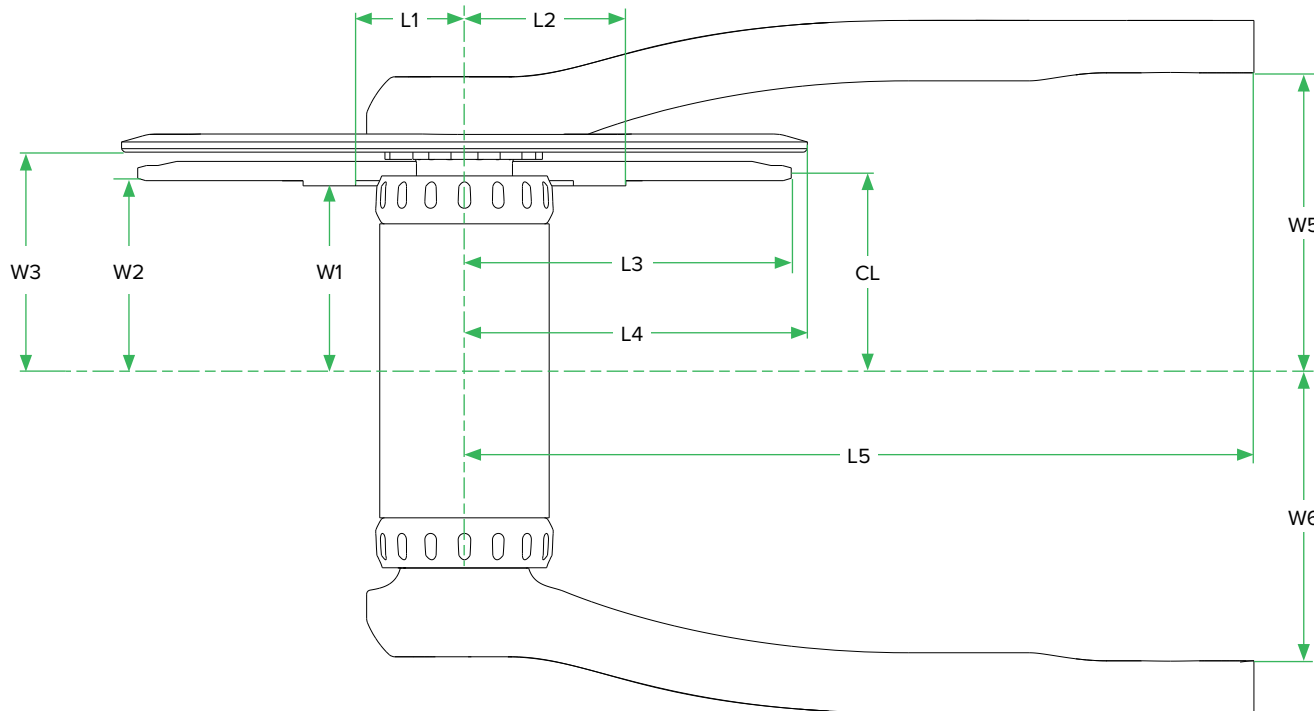

NX Power Spline - BOOST 148 Compatible

Crankset Frame Clearance

	Chainring	L1	L2	L3	L5	W1	W2	W5	W6	CL
1x11	28	-	31.5	60	192	51.8	50	73.5	73.5	52
	30			64						
	32			68						
Q-factor : 172						Bottom Bracket Type(s): Power Spline 118/73				

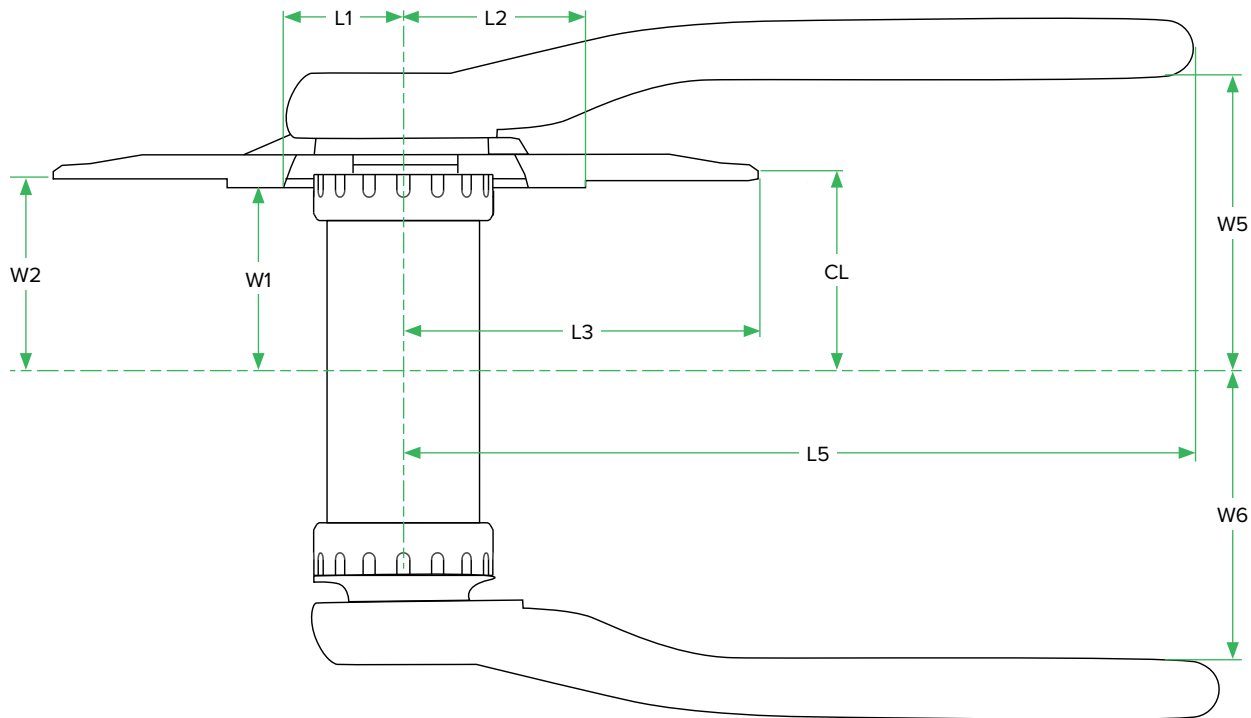

NX - Fatbike

Crankset Frame Clearance

	Chainring	L1	L2	L3	L5	W1	W2	W5	W6	CL
1x11	30	27	41	64.5	192	67	64.5	89.5	88	66.5
	32			68.5						
Q-factor : 203						Bottom Bracket Type(s): GXP : BB30 : PF30 : PFGXP				

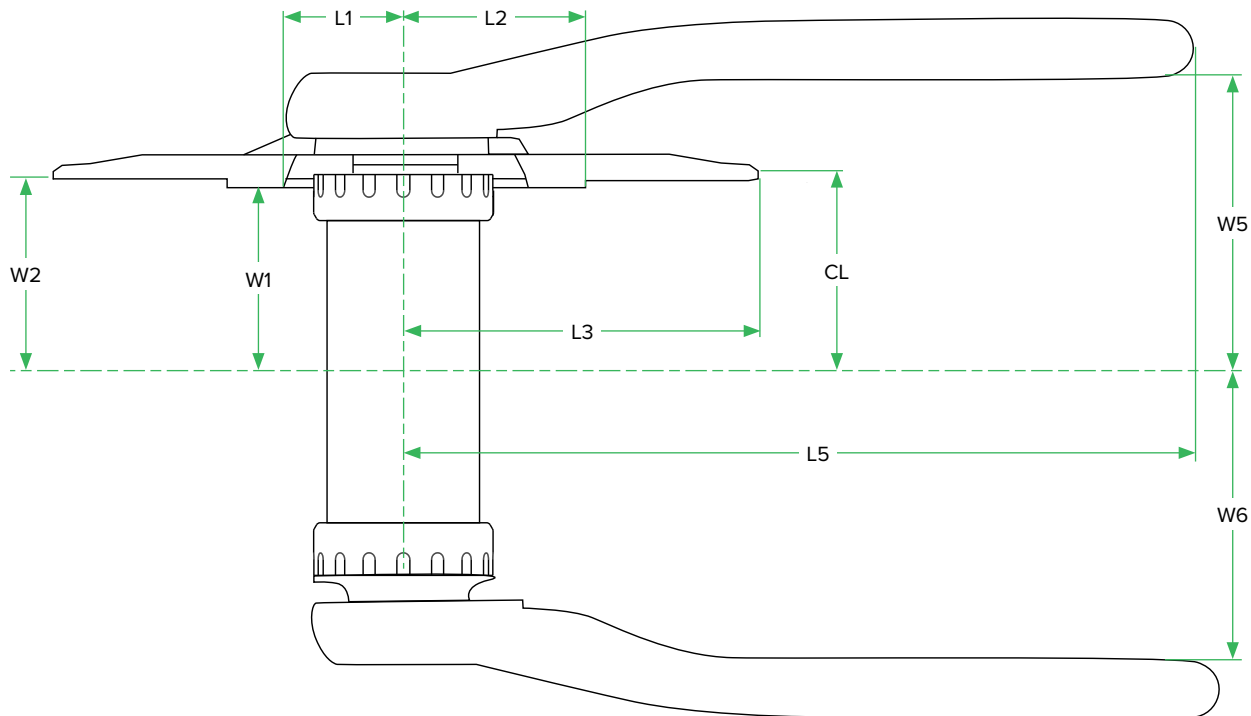

2x10 Cranksets

GX-1200

Crankset Frame Clearance

	Chainring	L1	L2	L3	L4	L5	W1	W2	W3	W4	W5	W6	CL
2x10	34/22	25	47.8	70.6	73	192	43	44	52	57.8	72	70.5	49
	36/22	25	46.7	74.4	78								
	38/24	24.5	50.7	78	82.5								
	39/26	31	55	81	-	192	43.5	44.5	52.5	-	72	70.5	49.5
	42/28	31	60	87	-								
Q-factor : 167.5							Bottom Bracket Type(s): GXP : BB30 : PF30 : PFGXP						

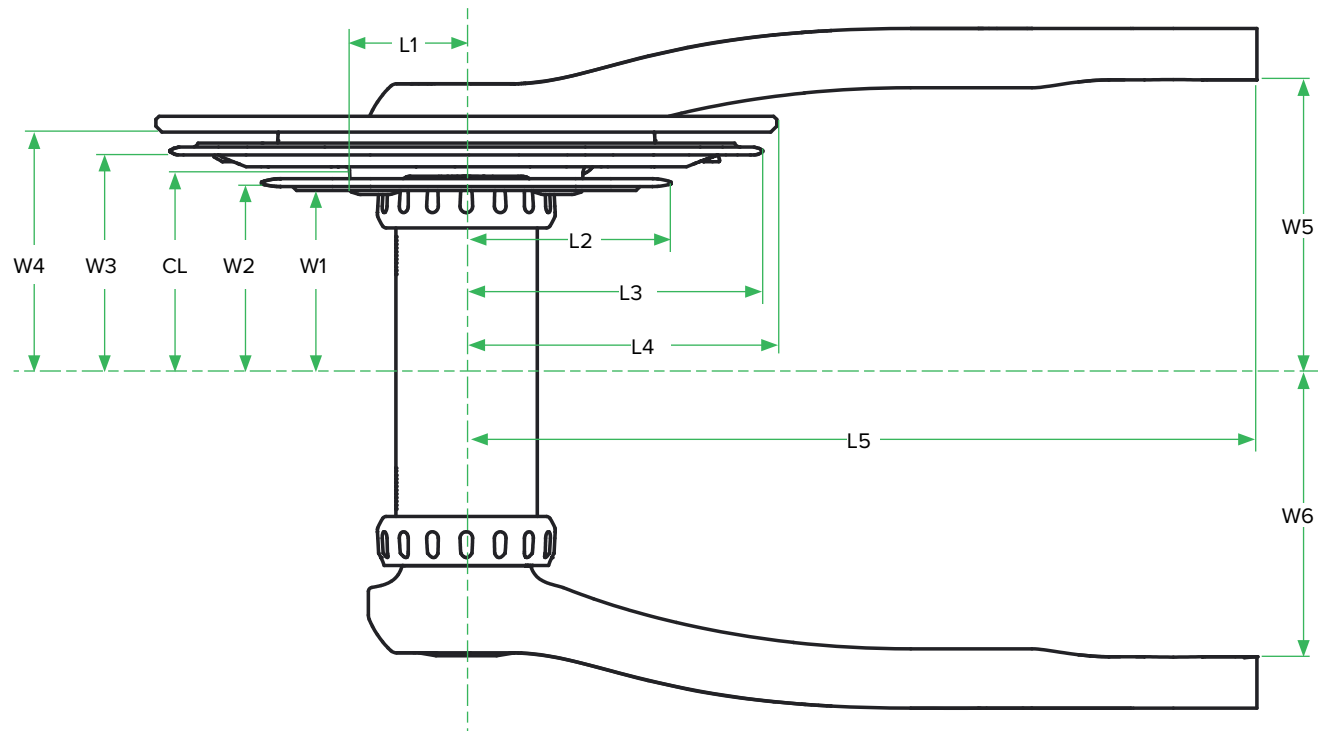

GX-1000/X5

Crankset Frame Clearance

	Chainring	L1	L2	L3	L4	L5	W1	W2	W3	W4	W5	W6	CL
2x10	34/22	25	47.8	70.6	73	192	43	44	52	57.8	72	72	49
	36/22	25	46.7	74.4	78								
	38/24	24.5	50.7	78	82.5								
	39/26	31	55	81	-	192	43.5	44.5	52.5	-	72	72	49.5
	42/28	31	60	87	-								
Q-factor : 169							Bottom Bracket Type(s): GXP : BB30 : PF30 : PFGXP						

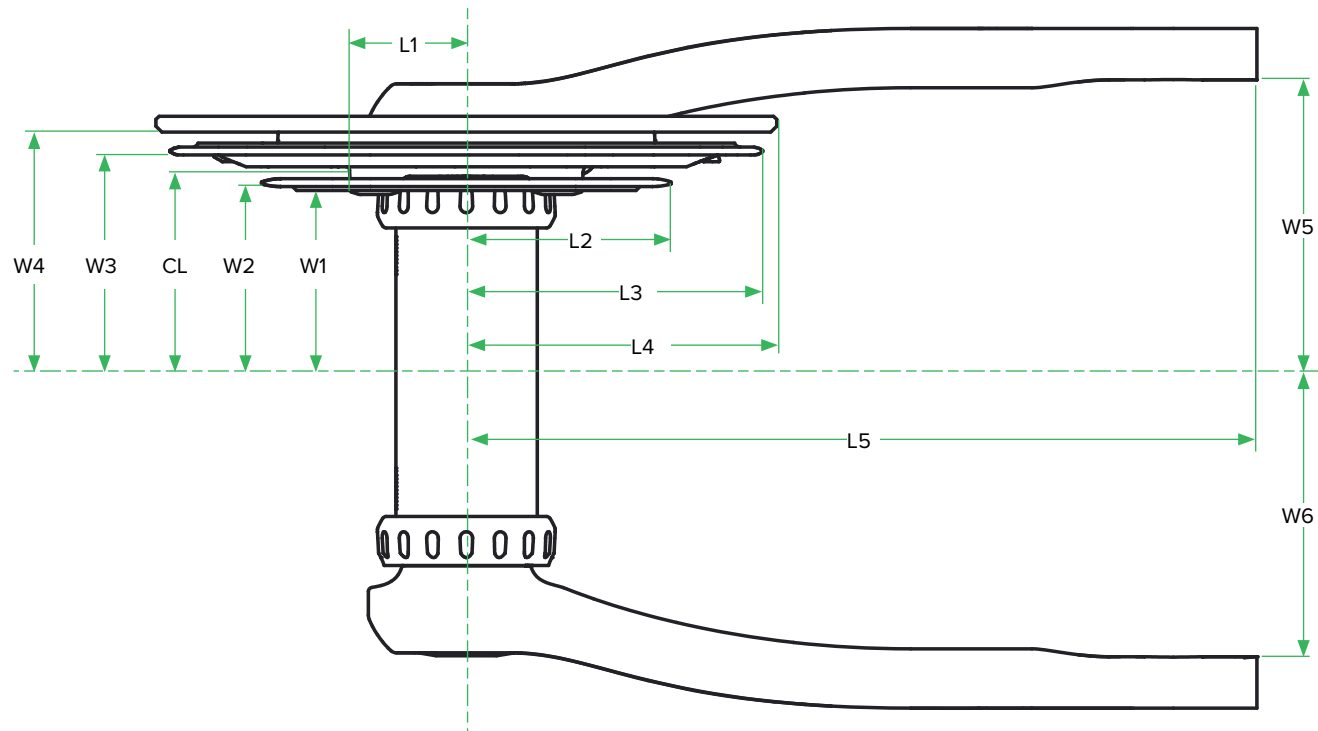

GX-1000 - BOOST 148 Compatible

Crankset Frame Clearance

	Chainring	L1	L2	L3	L5	W1	W2	W3	W5	W6	CL
2x10	34/22	25	47.8	70.6	192	46	47	55	72	72	52
	36/22	25	46.7	74.4							
	38/24	24.5	50.7	78							
Q-factor : 169						Bottom Bracket Type(s): GXP : BB30 : PF30 : PFGXP					

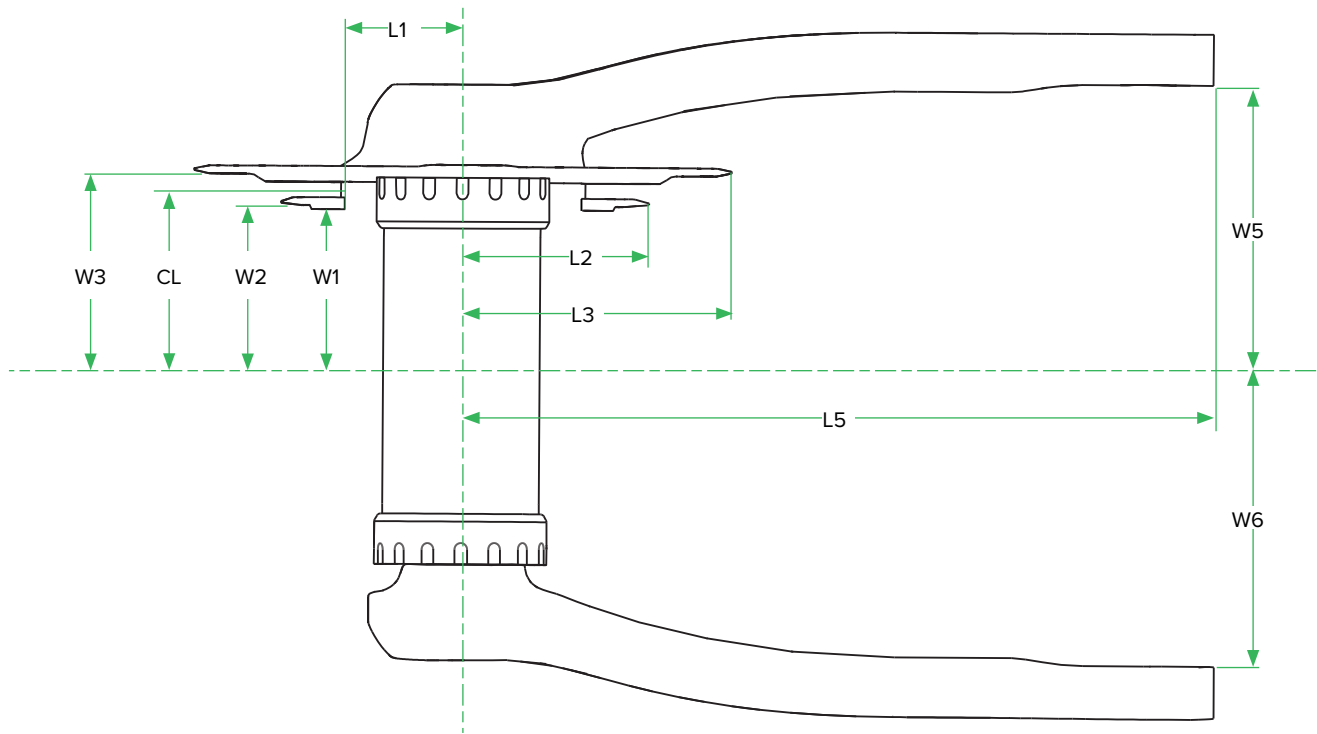

GX-1000/X5 - Fatbike

Crankset Frame Clearance

	Chainring	L1	L2	L3	L5	W1	W2	W3	W5	W6	CL
2x10	34/22	25	47.8	70.6	192	60.5	61.5	69.5	89.5	88	66.5
	36/22	25	46.7	74.4							
Q-factor : 202.5						Bottom Bracket Type(s): GXP 100 : PressFit 121					

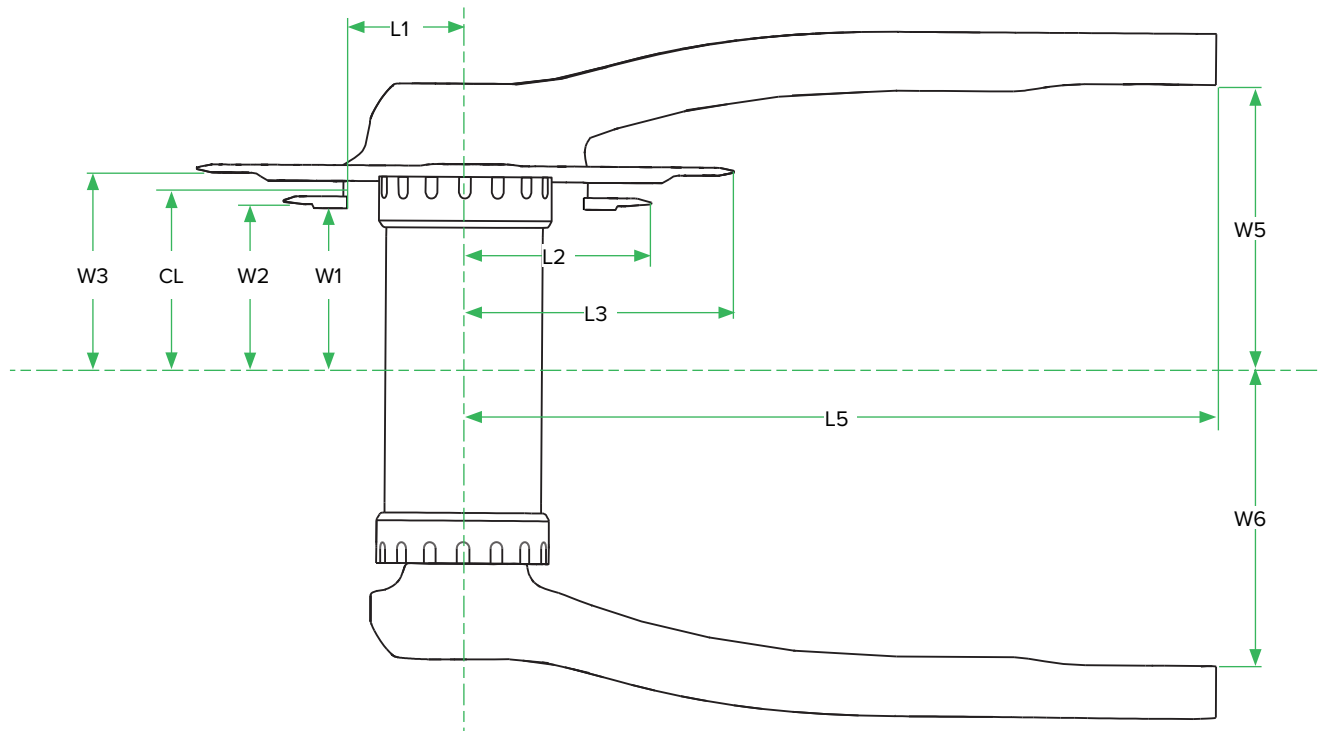

3x10 Cranksets

X5

Crankset Frame Clearance

	Chainring	L1	L2	L3	L4	L5	W1	W2	W3	W4	W5	W6	CL
2x10	44/34/22	25	47	69	91	191 (175 mm crank arm)	41	42	50	57	72	72	51
	Q-factor : 169						Bottom Bracket Type(s): GXP : BB30 : PF30 : PFGXP						

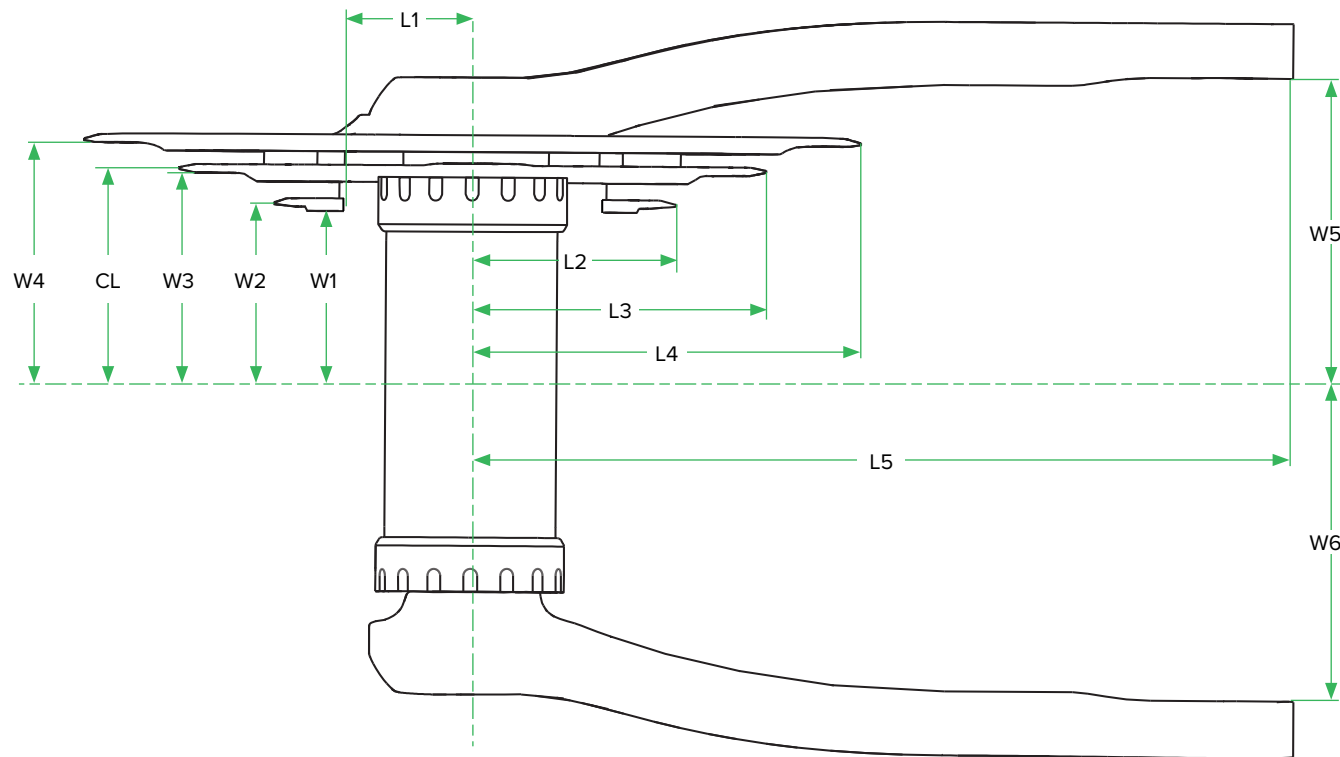

E-MTB Cranksets

S800E/X1-1000E/EX1 - BOSCH - Compatible

Crankset Frame Clearance

	Chainring	L2	L3	L4	L5	W1	W2	W3	W5	W6	CL
BOSCH GEN4	34	-	72	-	191.36	-	50.25	-	78.9	78.9	52
	36	-	76	-		-					
	36T guard	58		86		47		57.5			
	38	-	80	-		-	48.25	-			
	38T guard	58		86		47		57.5			
	38	-		-		-	-				
	38T guard	58		86		45	55.5	49+			
Based on crankarm length 175 mm				Q-factor: 183 (including pedal washers)				Bottom Bracket Type: ISIS integrated in BOSCH mid-ship motor			

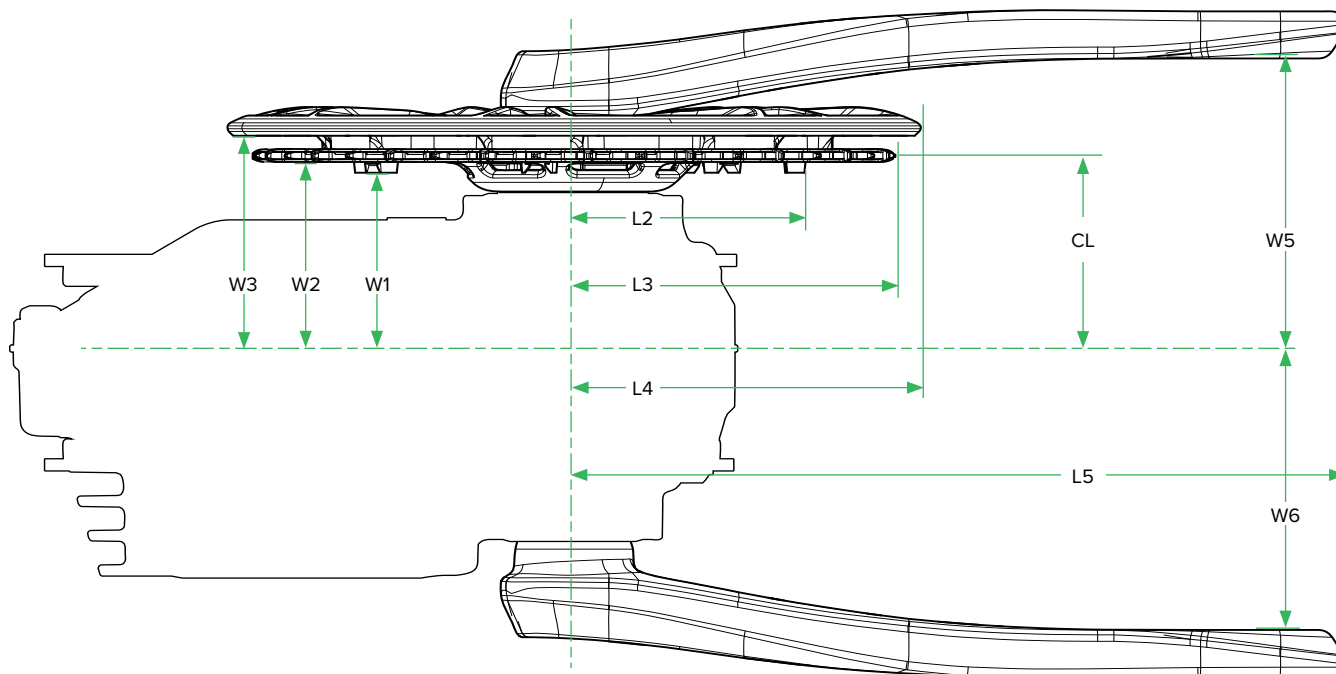

104 BCD Steel Chaining Spider Requirements

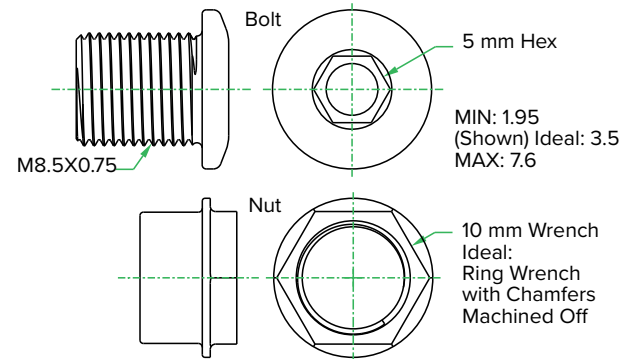
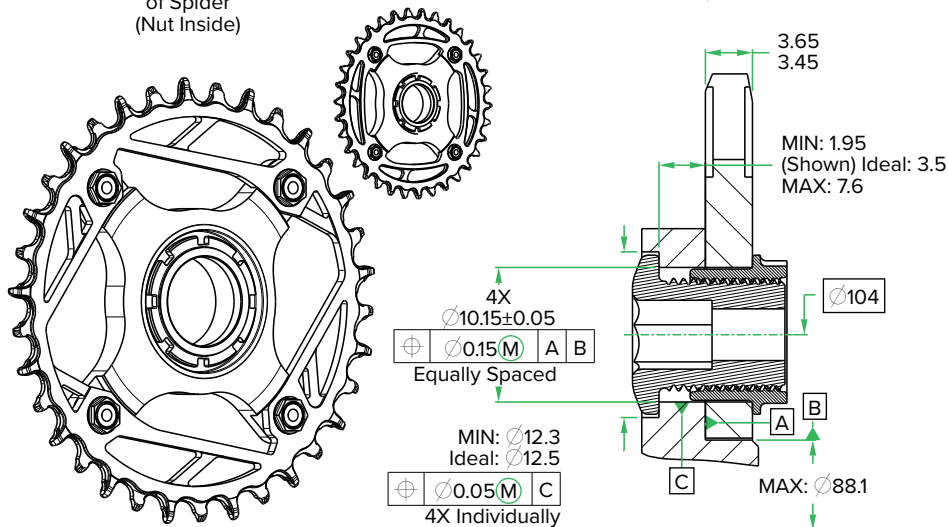
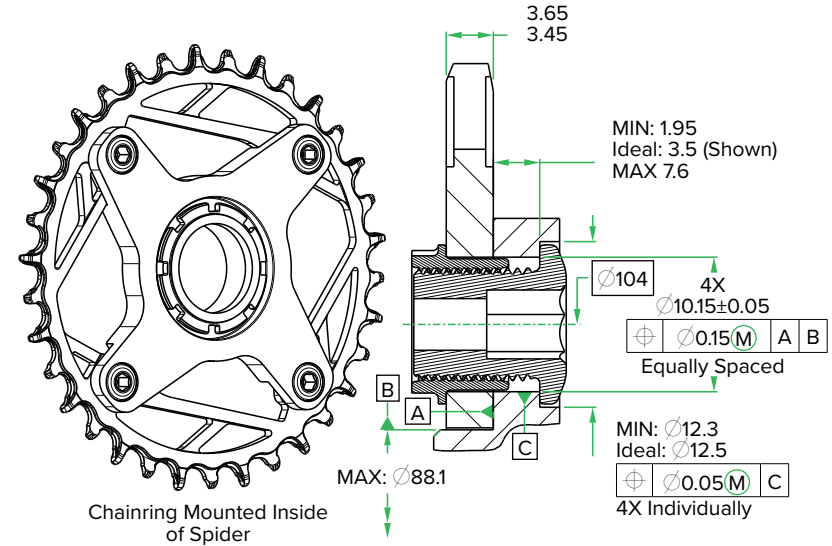
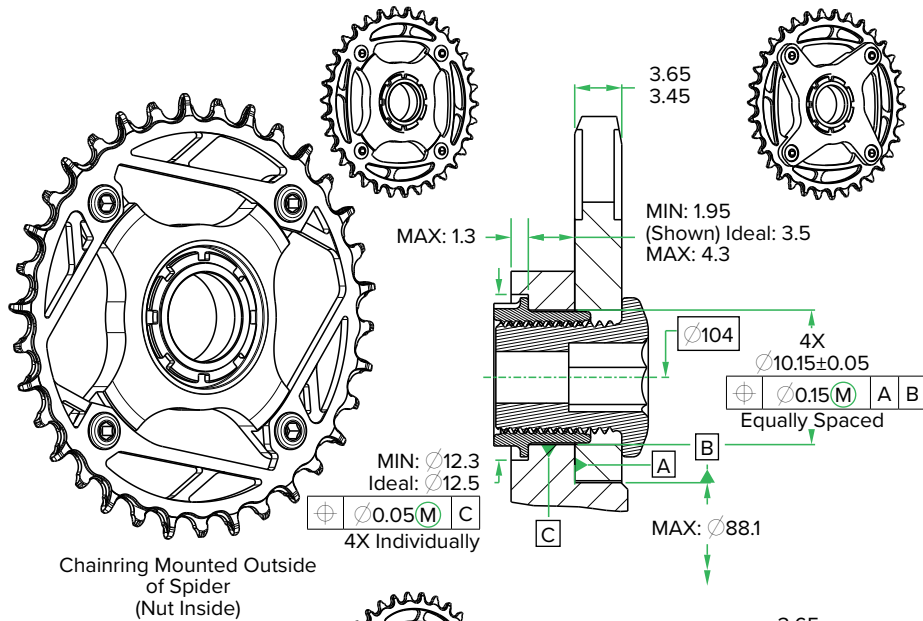

Notes:

- 1 Always double-check spider geometry for interference with CAD chaining files provided in SRAM Connect downloads

Bottom Bracket Shell Specifications

BSA 68/73/83/100

Bottom Bracket Shell Specifications

	W**	A*	B*
BSA 68	68	BC 1.37" x 24 TPI R.H.	BC 1.37" x 24 TPI L.H.
BSA 73	73		
BSA 83	83		
BSA 100	100		

*Reference JIS B 0225

**2.5 mm spacers may be used between the frame-shell and the adapter cups to adjust BB spacing.

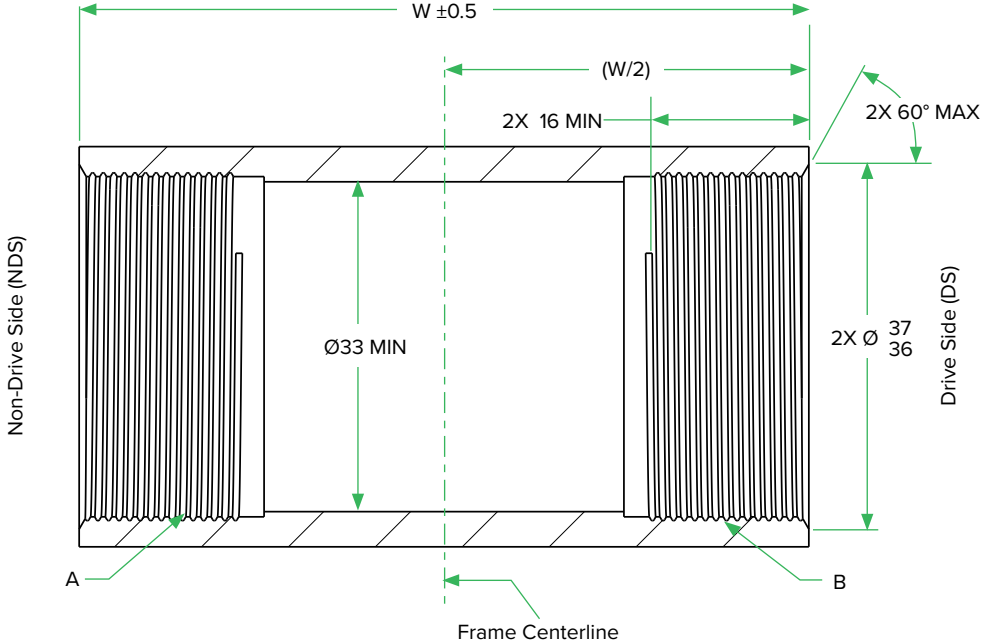
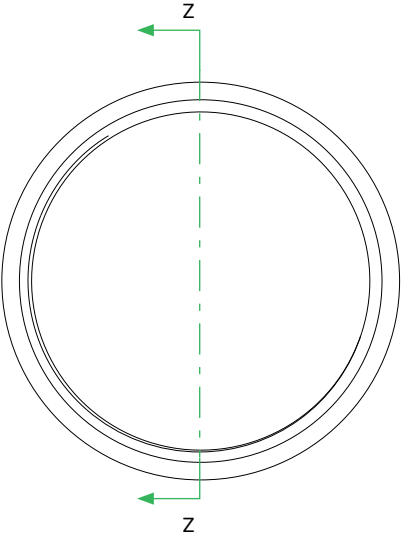

Section Z-Z

PressFit 30 73/83

MTB Bottom Bracket Frame Shell Specification

SRAM PressFit 30 (PF30) bottom brackets have been designed and tested to work within the bounds of the dimensions and tolerances in the shell specifications. Materials, manufacturing methods, and frame shell designs can potentially influence the performance of the bottom bracket, even when the shell is manufactured to these specifications. In these instances, it is recommended that bicycle manufacturers confirm the bottom bracket system performance when implemented in their design.

Things that should be considered when evaluating the frame and bottom bracket interaction include, but are not limited to:

- Loosening of the adapter cups from the bottom bracket shell (frame material choice can greatly affect friction coefficient).
- Binding of bearings within the bottom bracket.

For more information regarding PF30 bottom bracket technical information, contact your SRAM representative.

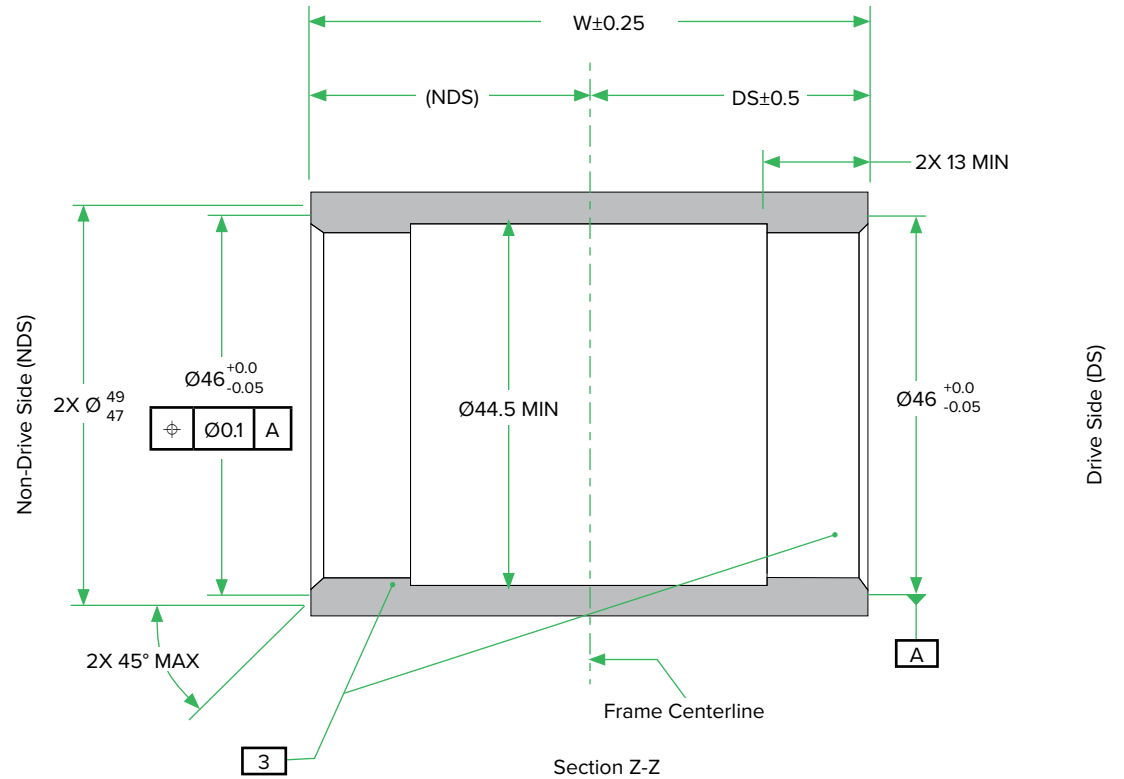
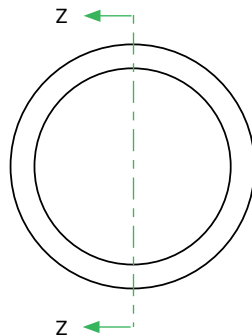

	Dim W	Dim DS	Dim NDS
PF30 73	73	36.5	36.5
PF30 83	83	41.5	41.5

- 1 Dimensions apply after finishing.
- 2 Only dimensions essential to bottom bracket PressFit and function are shown. All other details are left to the discretion of the frame or component designer. Dimensions shown do not take the place of proper frame, bottom bracket shell, or crankset design.
- 3 PressFit surfaces should be unpainted.

PressFit

Bottom Bracket Shell Specification

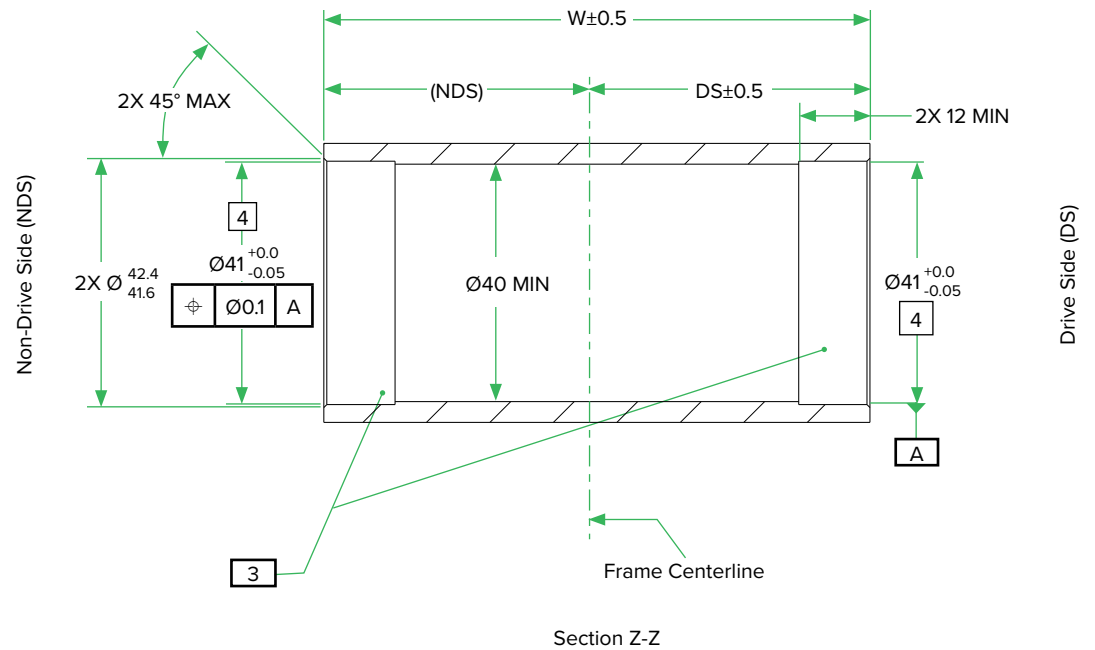
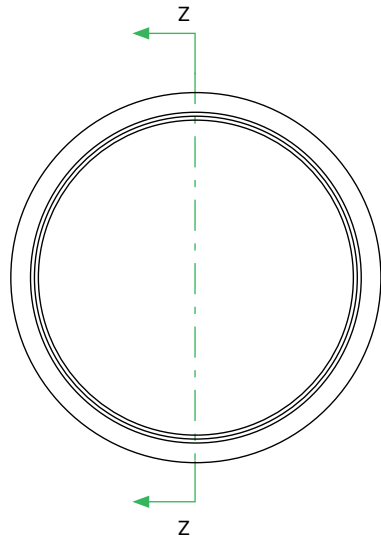

	Dim W	Dim NDS	Dim DS
PressFit 89.5	89.5	44.75	44.75
PressFit 92 ASYM	92	44.75	47.25
PressFit 104.5 DH	104.5	52.25	52.25
PressFit 107 DH ASYM	107	52.25	54.75
PressFit 121 Fatbike	121	60.5	60.5

- 1 Dimensions apply after finishing.
- 2 Only dimensions essential to bottom bracket PressFit and function are shown. All other details are left to the discretion of the frame or component designer. Dimensions shown do not take the place of proper frame, bottom bracket shell, or crankset design.
- 3 PressFit surfaces should be unpainted.
- 4 Tolerance applies to depth of 12 mm inboard from the outer face of each side.

BB30

Information

Information for the BB30 drawing and legal agreement can be found on www.BB30standard.com. Use of the information contained in the drawing is forbidden without reviewing and agreeing to the legal terms and conditions found on www.BB30standard.com. By using the information contained in the drawing you are certifying that you have agreed to the terms and conditions found within that legal agreement.

DUB Bottom Brackets

DUB BSA 68/73/83

Bottom Bracket Specification

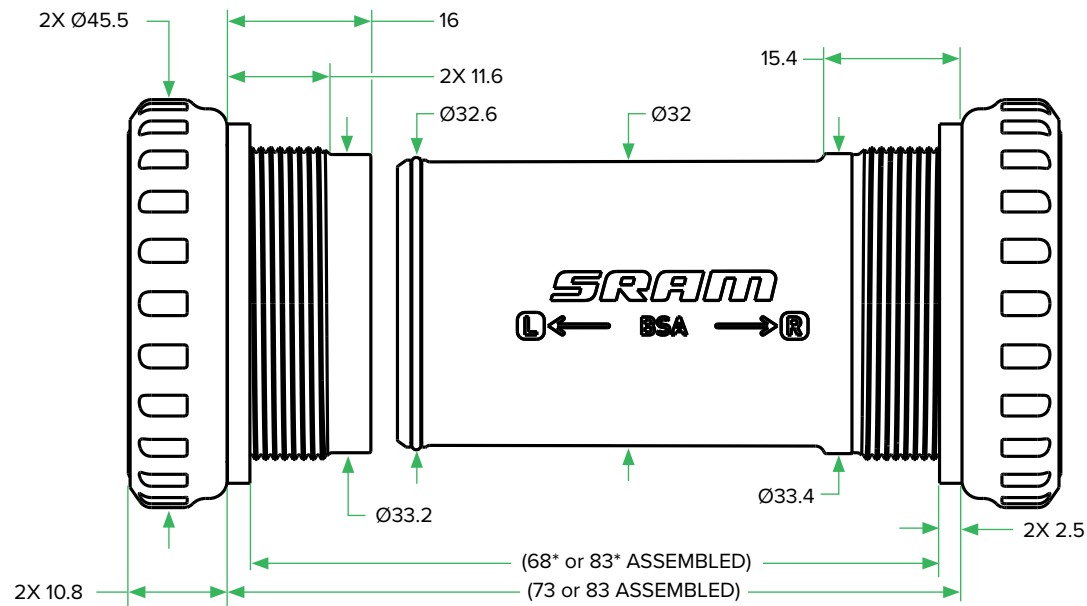

1 Dimensions apply after finishing.

2 Only dimensions essential to bottom bracket fit and function are shown. All other details are left to the discretion of the frame or component designer. Dimensions shown do not take the place of proper frame, bottom bracket shell, or crankset design.

* If a 68 mm configuration is used, 2 x 2.5 mm spacers must be installed.

DUB BSA 100

Bottom Bracket Specification

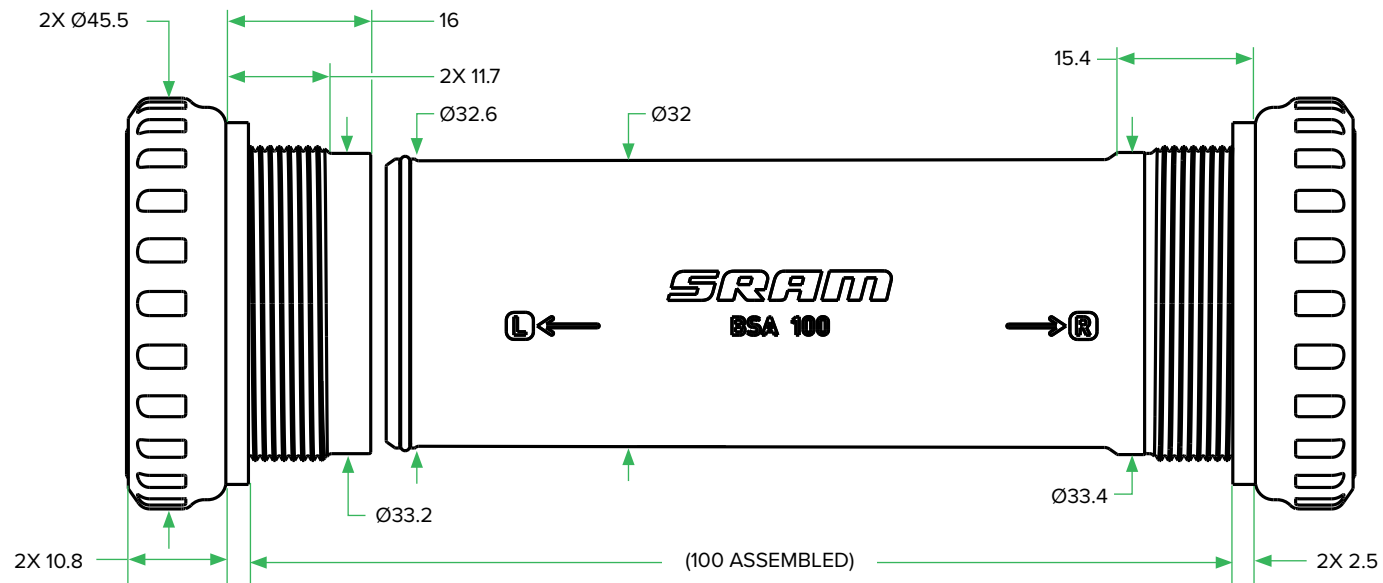

- 1 Dimensions apply after finishing.
- 2 Only dimensions essential to bottom bracket fit and function are shown. All other details are left to the discretion of the frame or component designer. Dimensions shown do not take the place of proper frame, bottom bracket shell, or crankset design.

DUB PressFit MTB

Bottom Bracket Specification

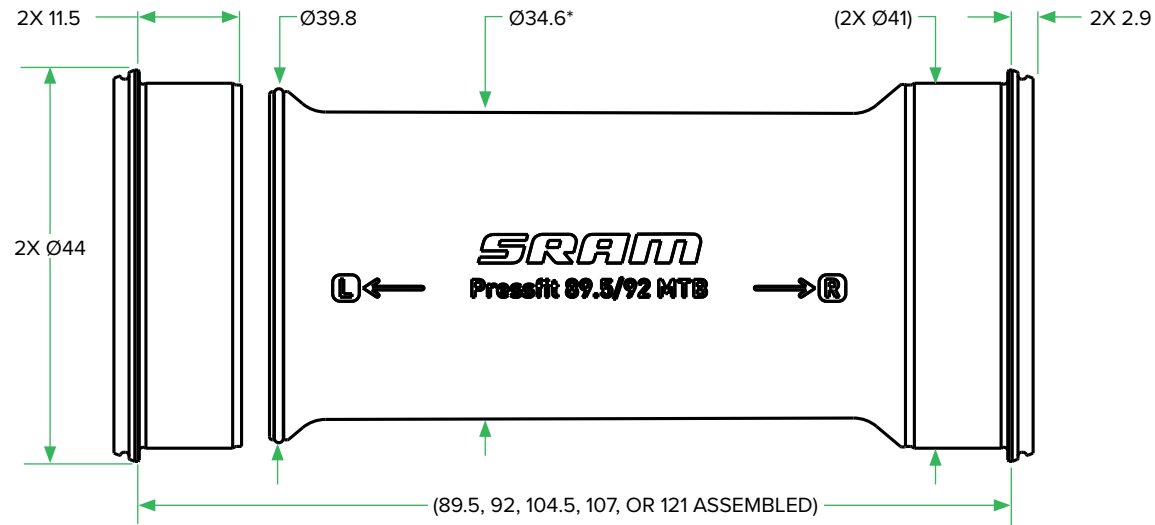

1 Dimensions apply after finishing.

2* Only dimensions essential to bottom bracket fit and function are shown. All other details are left to the discretion of the frame or component designer. Dimensions shown do not take the place of proper frame, bottom bracket shell, or crankset design.

Consider cable and hose clearances through the bottom bracket area of the frame.

3 Ensure that the bottom bracket cups are completely pressed into the frame shell. There should be no gap between the flange and the bottom bracket shell.

DUB PressFit 30

Bottom Bracket Specification

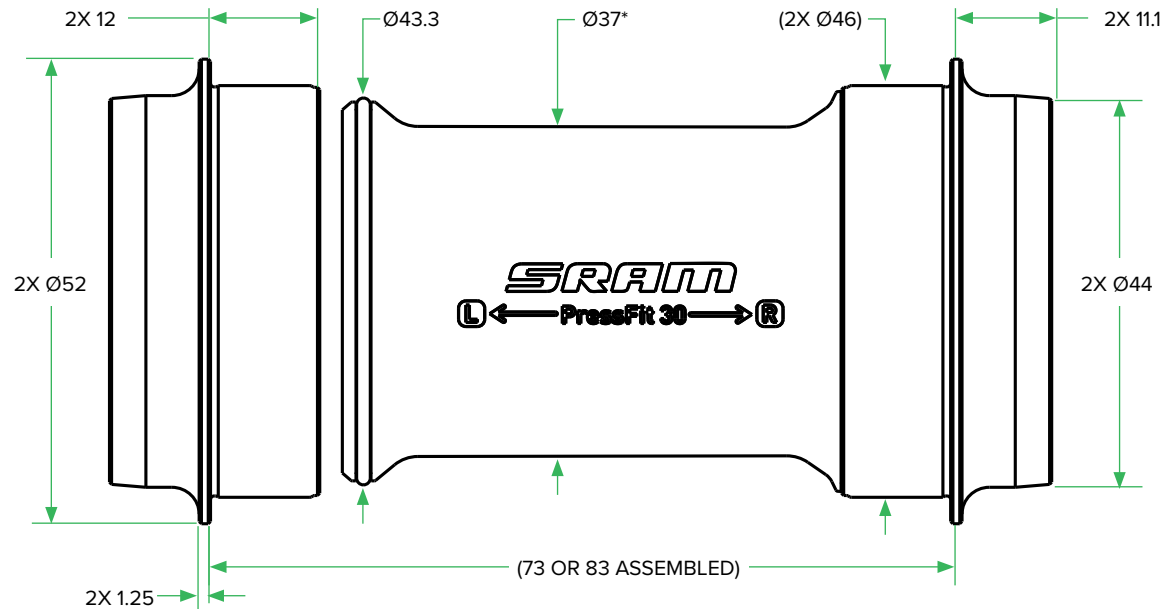

- 1 Dimensions apply after finishing.
- 2* Only dimensions essential to bottom bracket fit and function are shown. All other details are left to the discretion of the frame or component designer. Dimensions shown do not take the place of proper frame, bottom bracket shell, or crankset design.
Consider cable and hose clearances through the bottom bracket area of the frame.
- 3 Ensure that the bottom bracket cups are completely pressed into the frame shell. There should be no gap between the flange and the bottom bracket shell.

DUB BB30

Bottom Bracket Specification

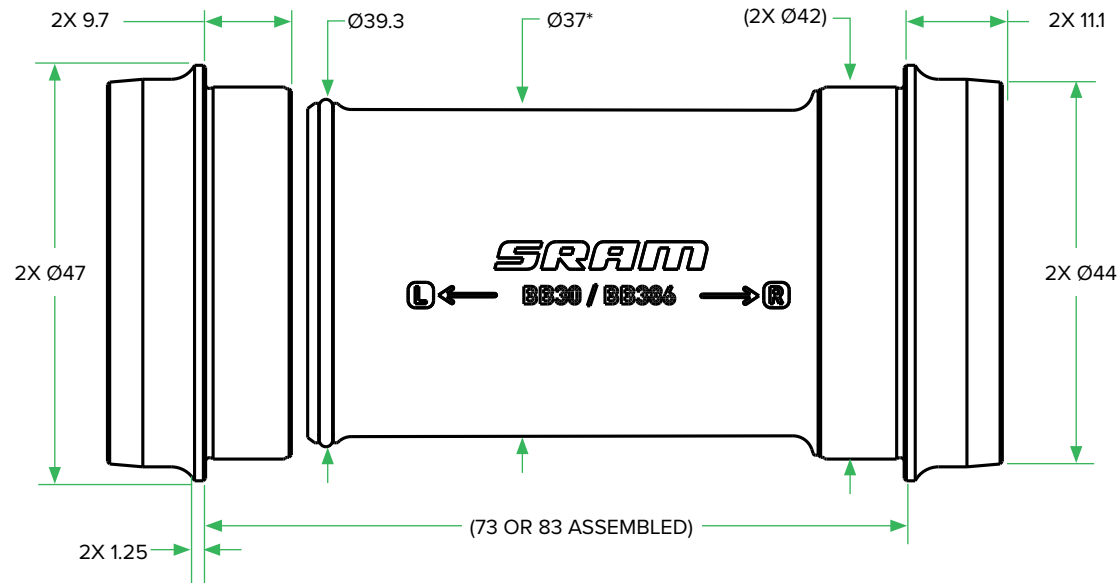

- 1 Dimensions apply after finishing.
- 2* Only dimensions essential to bottom bracket fit and function are shown. All other details are left to the discretion of the frame or component designer. Dimensions shown do not take the place of proper frame, bottom bracket shell, or crankset design.
Consider cable and hose clearances through the bottom bracket area of the frame.
- 3 Ensure that the bottom bracket cups are completely pressed into the frame shell. There should be no gap between the flange and the bottom bracket shell.

PressFit GXP 89.5/92

Bottom Bracket Specification

MTB Symmetric 89.5 Bottom Bracket

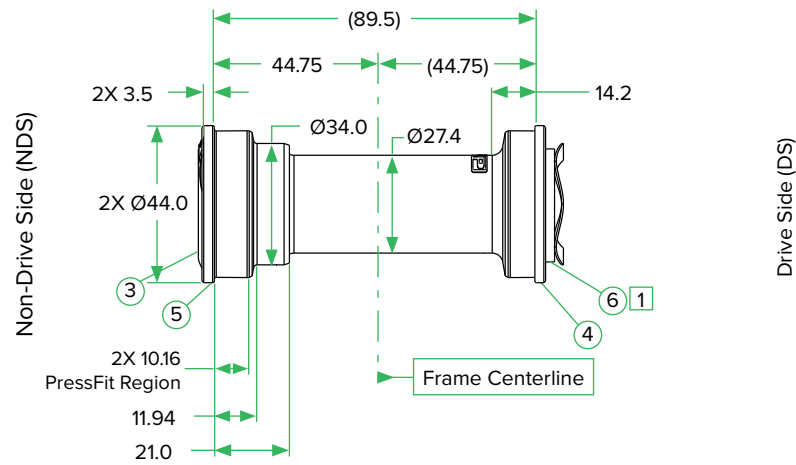

PressFit GXP MTB BB-Key Dimensions

ITEM NO.	DESCRIPTION
1	WAVE WASHER
2	DS SHIELD
3	NDS SHIELD
4	DS CUP
5	NDS CUP
6	DS SHIM WASHER 2.5 MM

1 DS shim washer to be used only on MTB symmetric shell.

MTB Asymmetric 92 Bottom Bracket

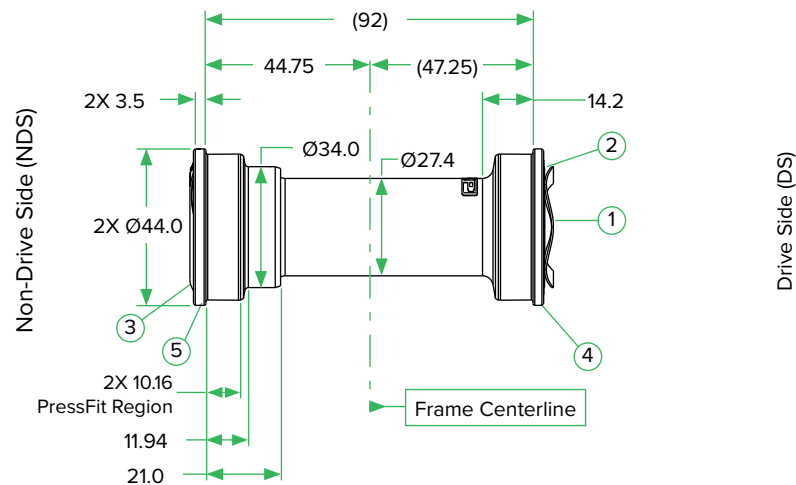

PressFit GXP 104.5 DH/107 DH

Bottom Bracket Specification

MTB Symmetric 104.5 DH Bottom Bracket

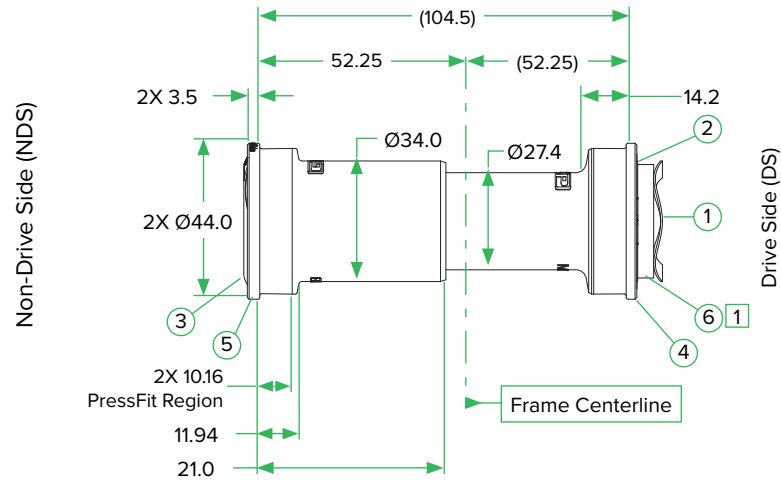

MTB Asymmetric 107 DH Bottom Bracket

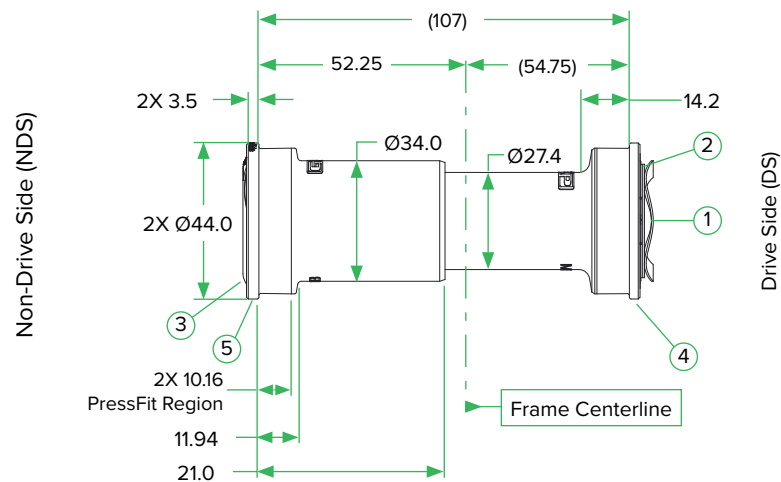

PressFit GXP MTB BB-Key Dimensions

ITEM NO.	DESCRIPTION
1	WAVE WASHER
2	DS SHIELD
3	NDS SHIELD
4	DS CUP
5	NDS CUP
6	DS SHIM WASHER 2.5 MM

1 DS shim washer to be used only on MTB symmetric shell.

PressFit GXP 121 Fatbike

Bottom Bracket Specification

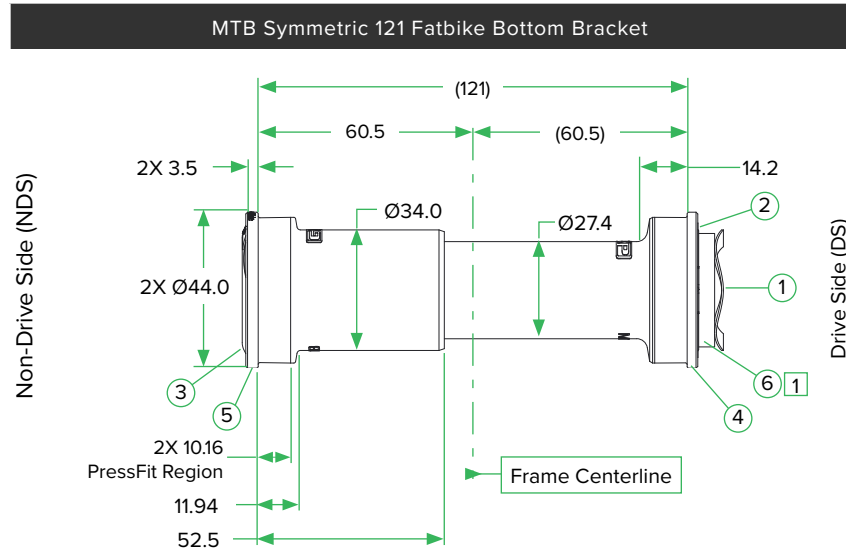

PressFit GXP MTB BB-Key Dimensions

ITEM NO.	DESCRIPTION
1	WAVE WASHER
2	DS SHIELD
3	NDS SHIELD
4	DS CUP
5	NDS CUP
6	DS SHIM WASHER 4.5 MM

1 DS shim washer to be used only on MTB symmetric shell.

PressFit 30

Bottom Bracket Specification

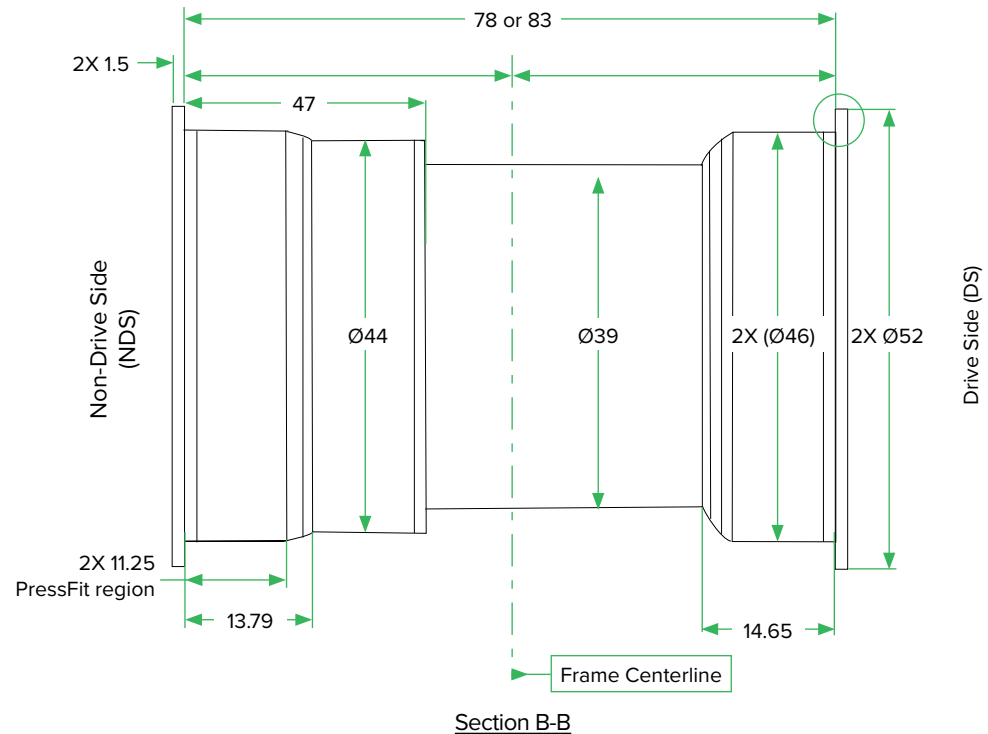
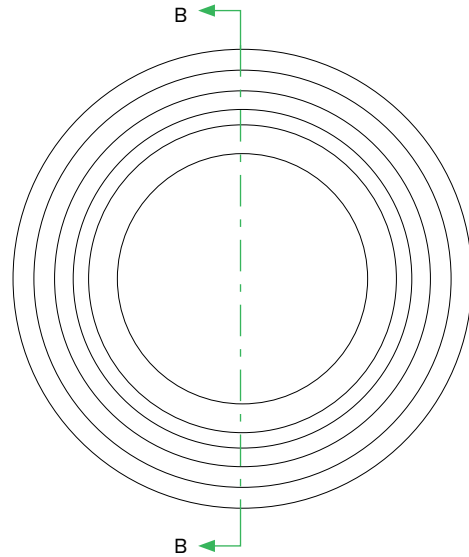

1 Dimensions apply after finishing.

2* Only dimensions essential to bottom bracket fit and function are shown. All other details are left to the discretion of the frame or component designer. Dimensions shown do not take the place of proper frame, bottom bracket shell, or crankset design.

Consider cable and hose clearances through the bottom bracket area of the frame.

3 Ensure that the bottom bracket cups are completely pressed into the frame shell. There should be no gap between the flange and the bottom bracket shell.

Wheels & Hubs

Splined MTB Driver Body Specifications

(for Compatibility with SRAM non-XD Cassettes)

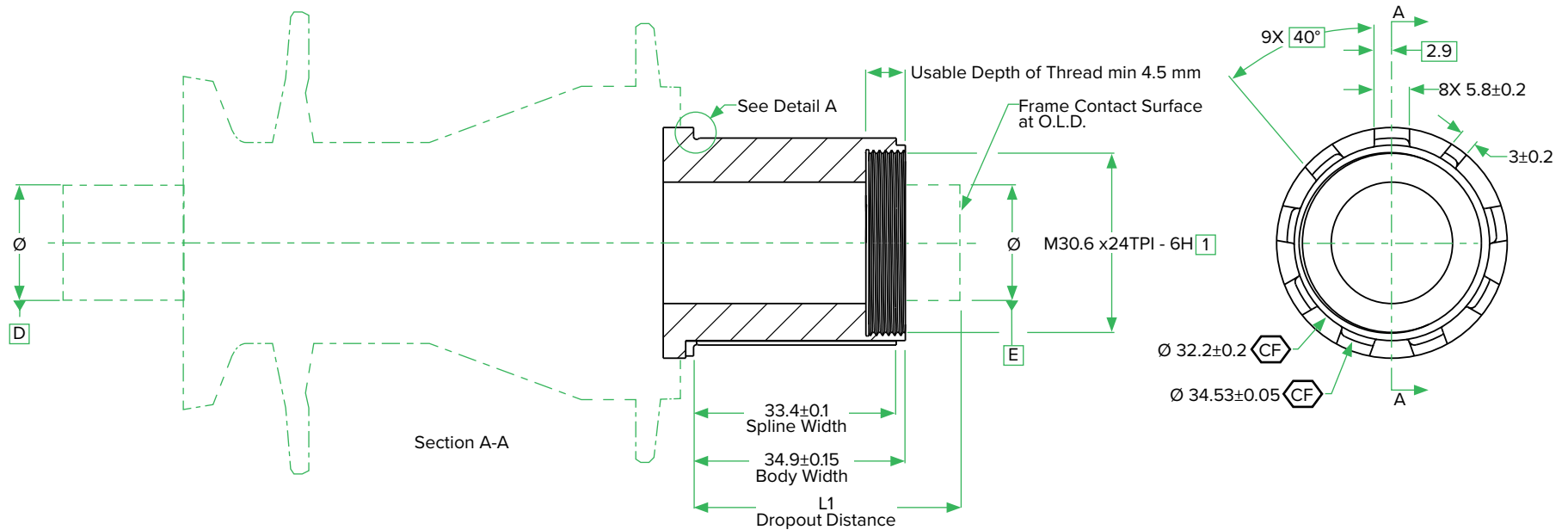

Hub O.L.D.	L1 +0.6 / -0.3
130	40.6
135	40.6
142	44.1
148	44.1
150	40.6
157	44.1

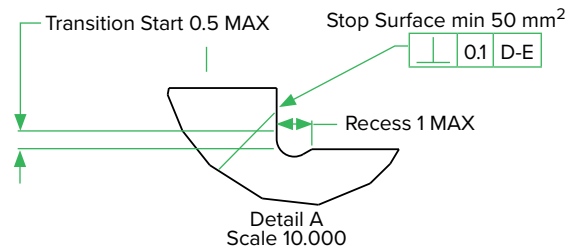
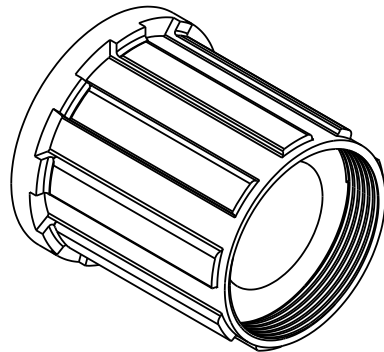

Notes:

- 1 Thread Per ISO-965
2. All Dimensions Valid for Complete Width of Driver Body.

Splined MTB Driver Body Specifications

(for Compatibility with SRAM non-XD Cassettes)

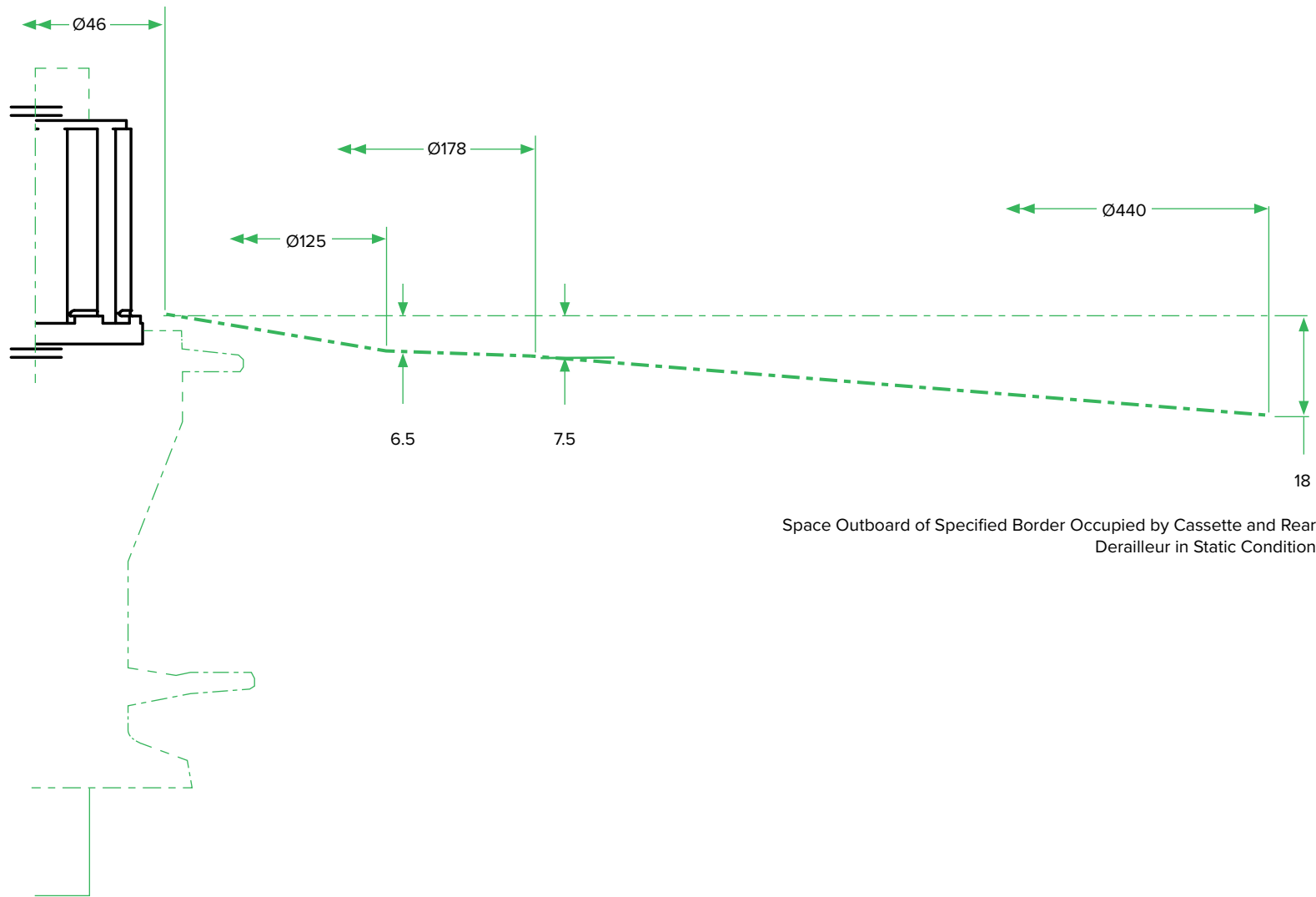

Maxle Description Decoder

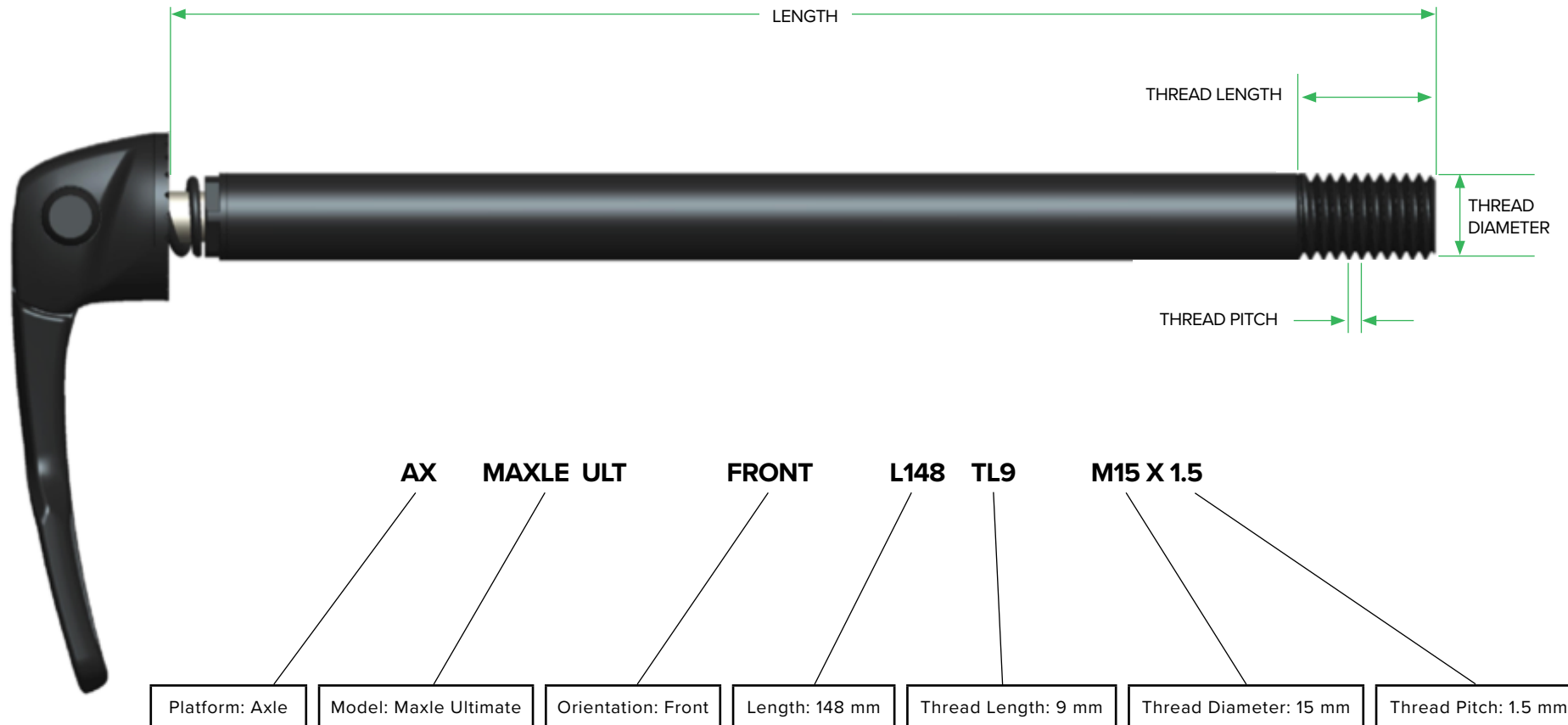

Maxle Ultimate

Frame/Fork Clearance

Lever in Closed Position

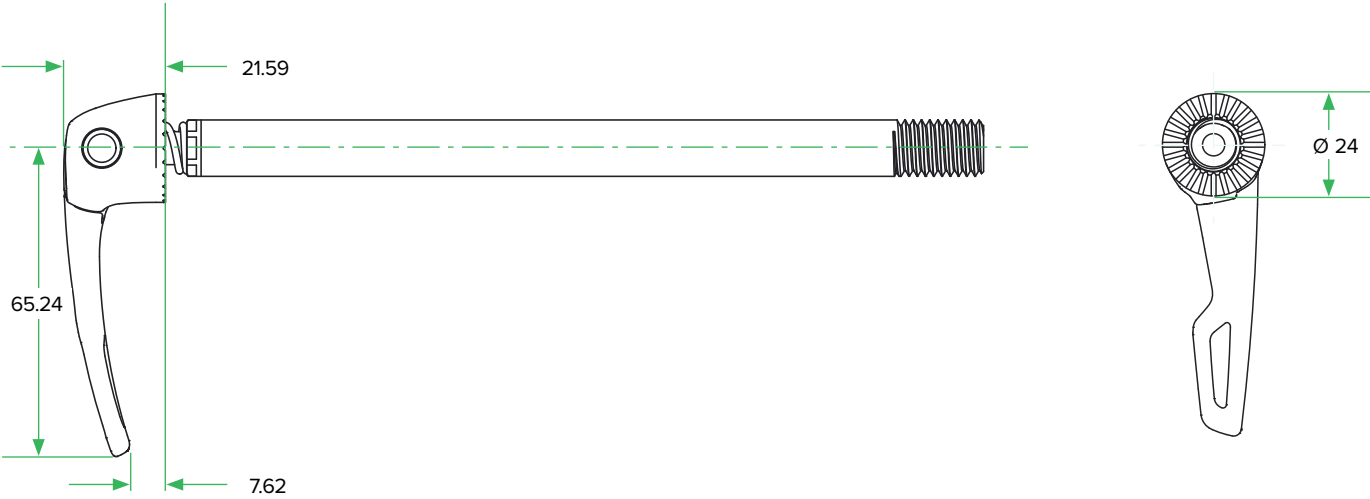

Lever in Open Position

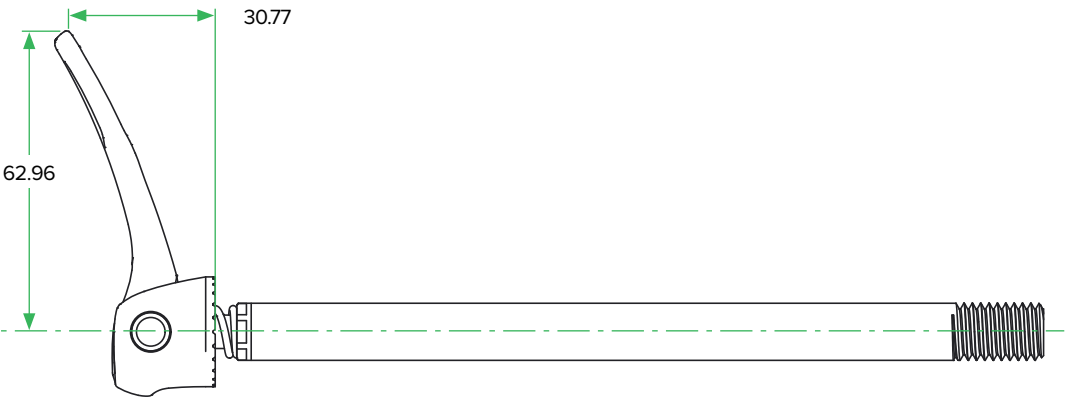

NOTES:

- 1 Drawing is not to scale.
- 2 Customer is responsible for ensuring hub, frame, and axle compatibility.
- 3 The frame manufacturer is responsible for ensuring the frame and/or fork assemblies using Maxles are compliant with existing safety standards.
- 4 Head translates along the Maxle axis approximately 1.46 mm when lever is moved from open to closed.

Maxle Stealth

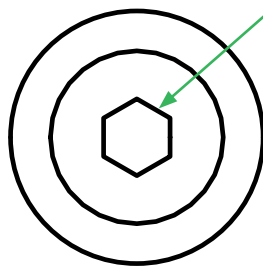
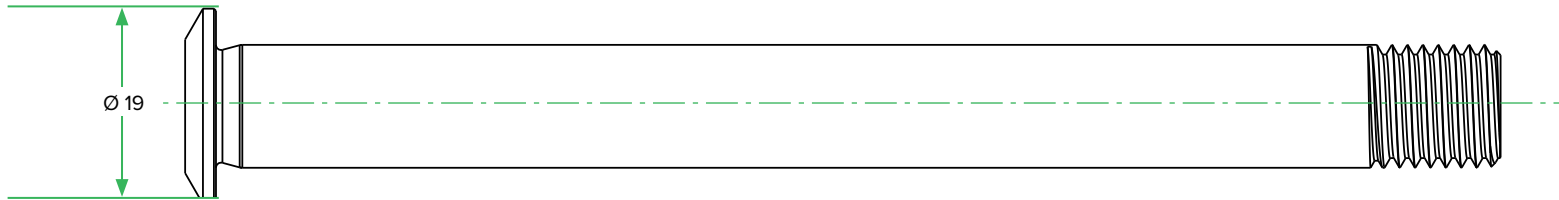

SEE TABLE

DESCRIPTION	HEX SIZE	TORQUE VALUE
Maxle 12	5	9-13.5 N•m
Maxle 15	6	9-13.5 N•m

NOTES:

- 1 Drawing is not to scale.
- 2 Customer is responsible for ensuring hub, frame, and axle compatibility.
- 3 The frame manufacturer is responsible for ensuring the frame and/or fork assemblies using Maxles are compliant with existing safety standards.

Maxle Lite & Maxle

Frame/Fork Clearance

Lever in Closed Position

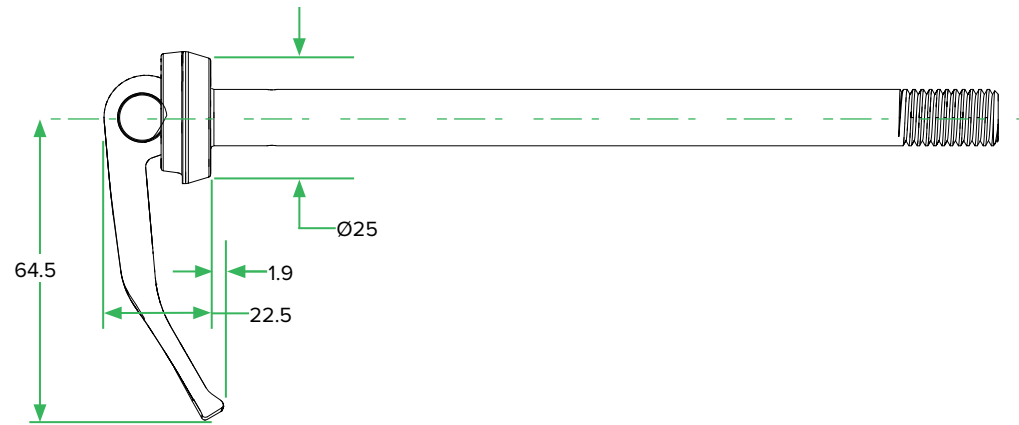

Lever in Open Position

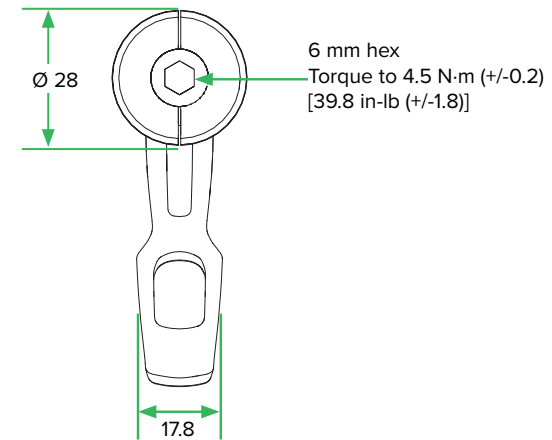

- 1 Drawing is not to scale.
- 2 Customer is responsible for ensuring hub, frame, and axle compatibility.
- 3 The frame manufacturer is responsible for ensuring the frame and/or fork assemblies using Maxles are compliant with existing safety standards.

Maxle, Maxle Lite, Maxle Ultimate, Maxle Stealth

Rear Frame Specification

Frame dropouts with axle installed

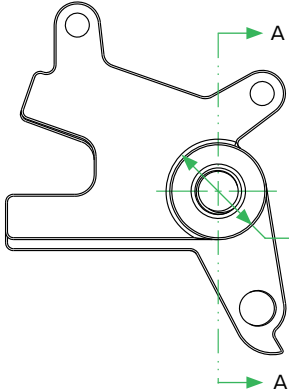
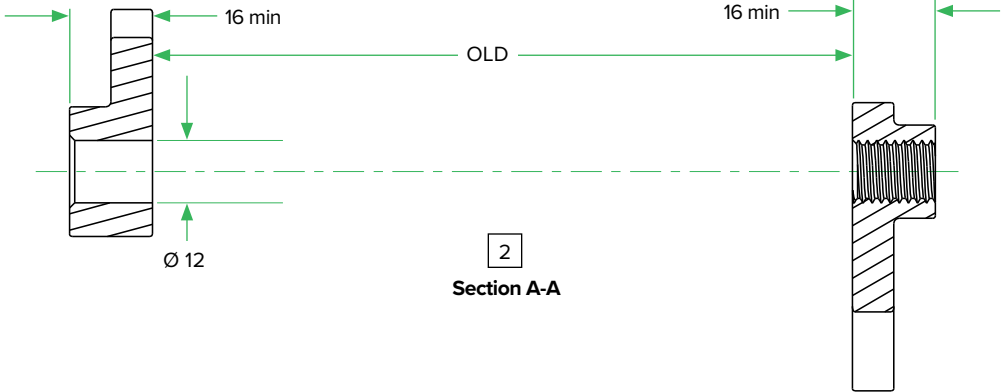
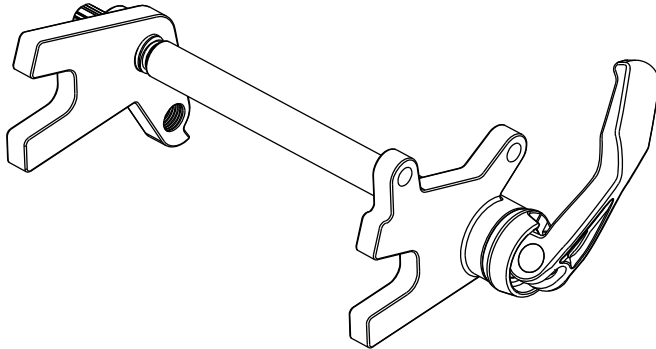

24 min flat surface

- 1 Drawing is not to scale.
- 2 Frame designers may request a custom Maxle for their specific frame dropouts. However, frame designers are responsible for ensuring compatibility between their frame and custom Maxle.

Part Number	Description
00.4318.009.001	AX MAXLE ULT REAR L174 TL20 M12X1.75
00.4318.009.013	AX MAXLE ULT REAR L180 TL20 M12X1.75
00.4318.017.004	AX MAXLE STLTH REAR L174 TL20 M12X1.75
00.4318.017.005	AX MAXLE STLTH REAR L180 TL20 M12X1.75

- 1 Drawing is not to scale.
- 2 Dimensions apply to the standard Maxle sizes in the table.
- 3 Frame designers may request a custom Maxle for their specific frame dropouts. However, frame designers are responsible for ensuring compatibility between their frame and custom Maxle.

Maxle, Maxle Lite, Maxle Ultimate, Maxle Stealth

Fork Specification

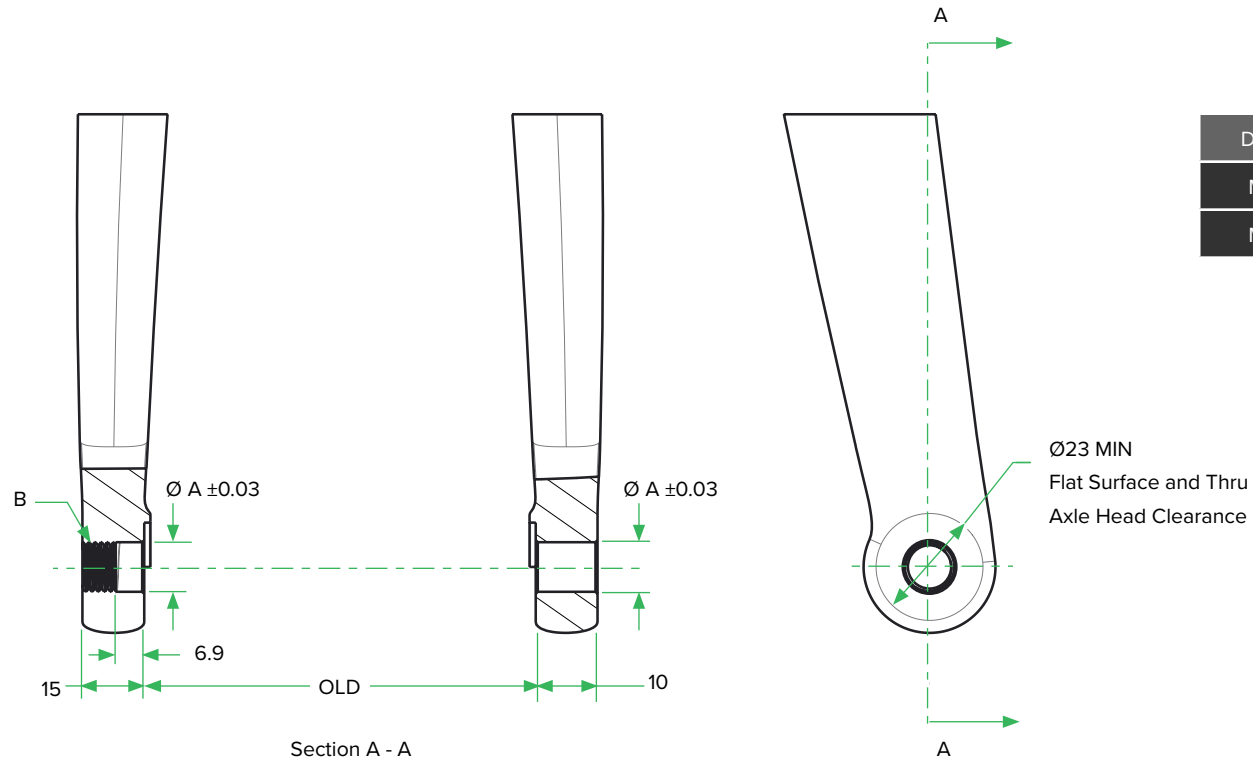

Description	A	B
MAXLE 15	14.98	M15 X 1.5 - 6H
MAXLE 12	12.03	M12 X 1.5 - 6H

- 1 Drawing is not to scale.
- 2 Customer is responsible for ensuring hub, frame, and axle compatibility.
- 3 The frame manufacturer is responsible for ensuring the frame and/or fork assemblies using Maxles are compliant with existing safety standards.

Maxle, Maxle Lite, Maxle Ultimate, Maxle Stealth

Fork Specification

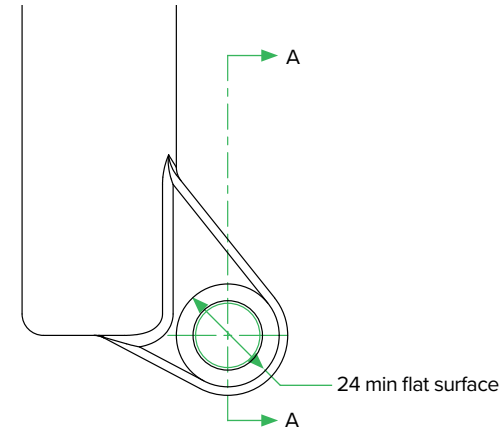
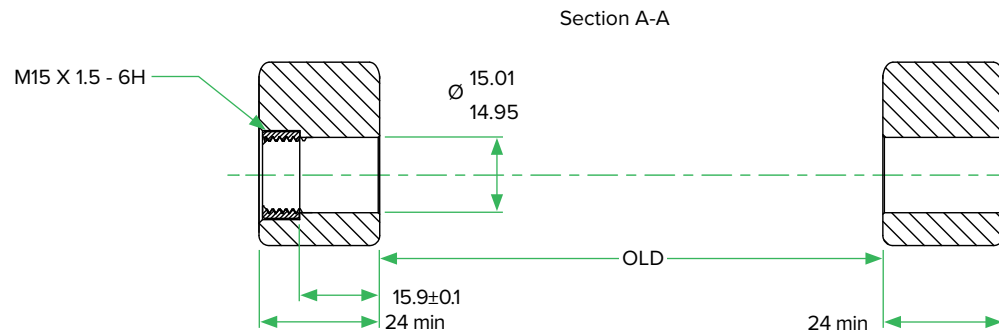

- 1 Drawing is not to scale.
- 2 Customer is responsible for ensuring hub, frame, and axle compatibility.
- 3 The frame manufacturer is responsible for ensuring the frame and/or fork assemblies using Maxles are compliant with existing safety standards.

Brakes

Brake Fluid & Hydraulic Line

Disc Brake Hose Length Specification

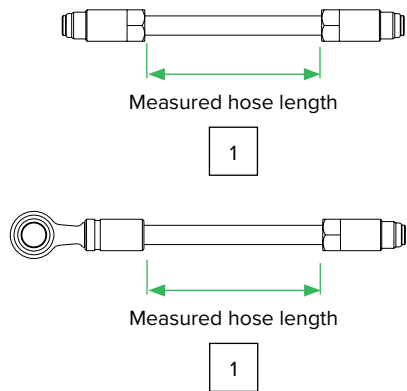

OEM shipping condition - brakes are shipped filled and pre-bled, unless otherwise specified.

Calculating Hydraulic Line Lengths:

The brakes should be installed with the hose properly routed and secured to the bicycle. To determine where to cut the hose, hold the hose up to the brake lever with a length that creates a gentle bend in the hose and allows the handlebar to freely turn from side to side. For internally-routed frames, insert the hose through the frame, determine the proper length, then cut the hose.

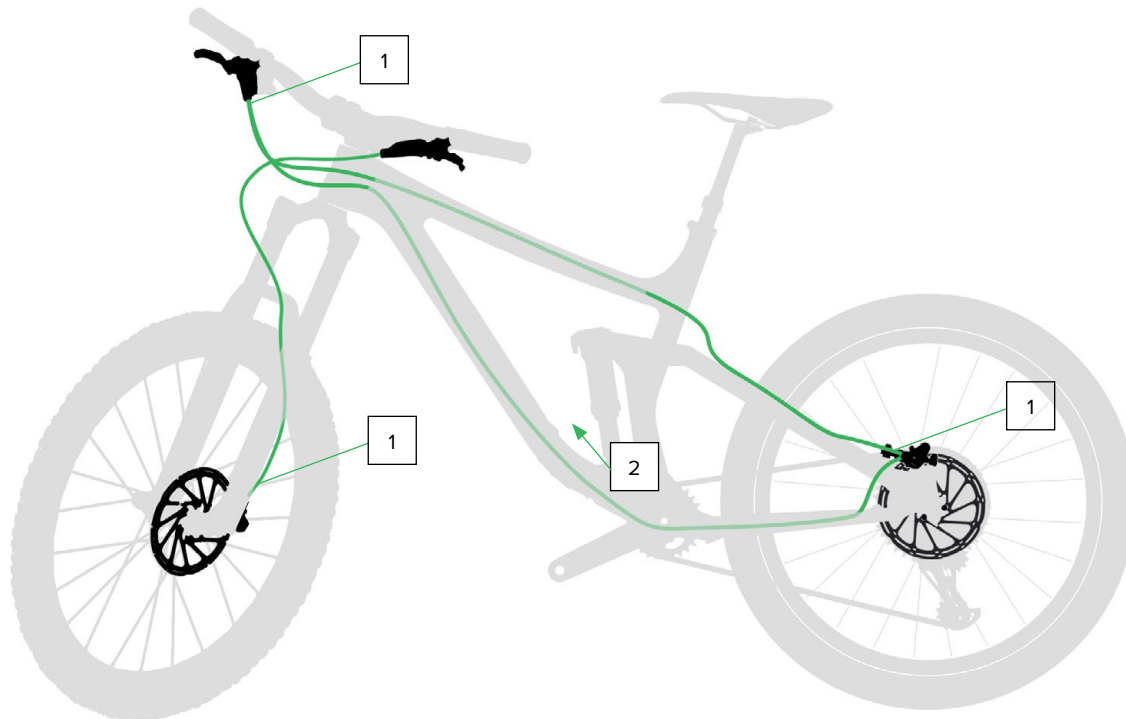

- 1 FG (Finished Good) hose equals the measured hose length from the lever body to the caliper plus 35 mm.
- 2 The SJ (Stealth-a-majig) hose routing is from back to front of bike.
- 3 For internal routing, the SJ connection requires a hole in the frame or fork that is at least $\text{Ø}5.1$ mm.
- 4 Hose bend radius at 20°C = 30 mm minimum.
- 5 All surfaces that come in contact with brake hose to be free of burrs and sharp edges.
- 6 SJ is used for initial assembly only. A bleed is required if the system is disconnected and reconnected.
- 7 SRAM Brake systems are not compatible with mineral based fluids such as damping fluid, mineral oil, fork fluid, or RockShox Reverb fluid. **Use only DOT 4 and DOT 5.1 brake fluids with SRAM Hydraulic brakes.**

SRAM MTB Hydraulic Disc Brakes

Safety Guidelines for Rotor Size and Brake Pad Material

SRAM disc brakes pass laboratory testing designed to simulate worst case riding conditions. The rotor size and pad compound materials recommendations were generated through controlled testing. Use of any combination not mentioned below will void the warranty and could result in a crash.

Front Rotor Size	160	180	180	200	200	220	220
Rear Rotor Size	160	160	180	180	200	200	220
Weight Rider+Bike (kg)	190	210	215	235	240	260	265

	Intended use	Brake pad material	Minimum rotor size (mm)
Riding Type	Road Riding	Organic or Metal Sintered	160
	Cyclocross Racing	Organic or Metal Sintered	140
	Cross Country Mountain Biking	Organic or Metal Sintered	160
	Downhill Mountain Biking	Organic or Metal Sintered	160

⚠️ WARNING - CRASH HAZARD

SRAM disc brakes pass laboratory testing designed to simulate worst case riding conditions. The rotor size and pad compound materials recommendations were generated through controlled testing. Use of any combination not mentioned above will void the warranty and could result in a crash.

Mounting Options

Flat Mount, Post Mount, and International Standard Mount

Flat Mount

Flat Mount Bracket

A bracket may be needed to attach the caliper to the frame or fork.

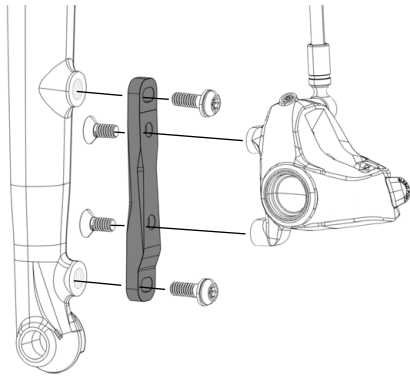

Flat Mount (Direct)

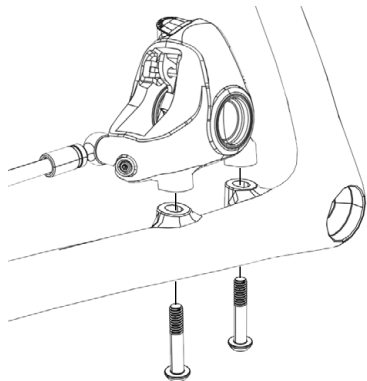

Post Mount

Direct Mount (Direct)

No post brackets or spacers are needed to attach the caliper to the frame or fork.

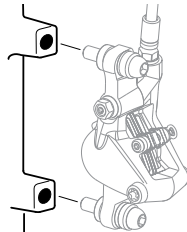

Post Spacers (S)

Some rotor sizes require the use of spacers to fit the caliper on the frame or fork.



Post Brackets (P)

Some rotor sizes require the use of post brackets to fit the caliper on the frame or fork.



International Standard Mount (IS)

International Standard Bracket (IS)

SRAM brakes are Post Mount. To convert an IS frame or fork to Post Mount, an IS bracket is required.

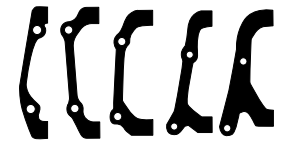
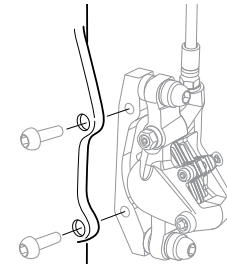

Post Mount Fork Specification

All SRAM Post Mount Calipers

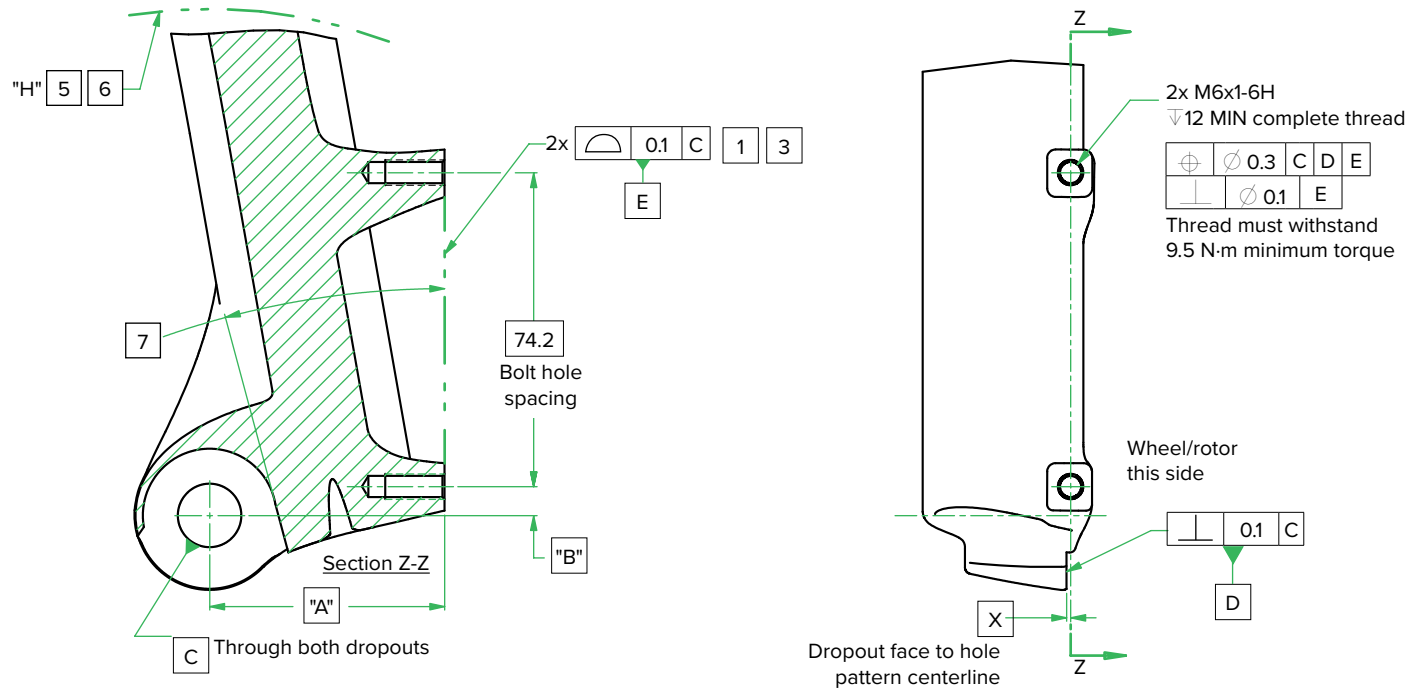

Rotor Ø (mm)	A	B	H (Radius)
140	47.24	1.8	140
160	55.9	6.8	150
180	64.56	11.8	160
200	73.22	16.8	170
203	73.9	18.8	172
220	81.88	21.8	180

Hub Standard	X
9x100 (QR)	0.94
15x100	
15x110 Boost	
20x110 Boost	5.94
Legacy 20x110	

- There is potential for the fork and caliper interface to be exposed to high temperatures. This should be evaluated on all designs.
- All dimensions and tolerances apply in free state and as assembled.
- Surfaces must be free from paint.
- All dimensions applied after paint unless otherwise specified.
- All surfaces that come in contact with brake hose should be free of burrs and sharp edges.
- Internal hose routing hole position radius "H" mm MIN from dropout ϕ .
- Wheel installation may be impeded by rotor-to-caliper interference when wheel installation path approaches or is less than 20°.

Disc Brake Mount Specification

International Standard Fork Mount

International Standard Fork Mount

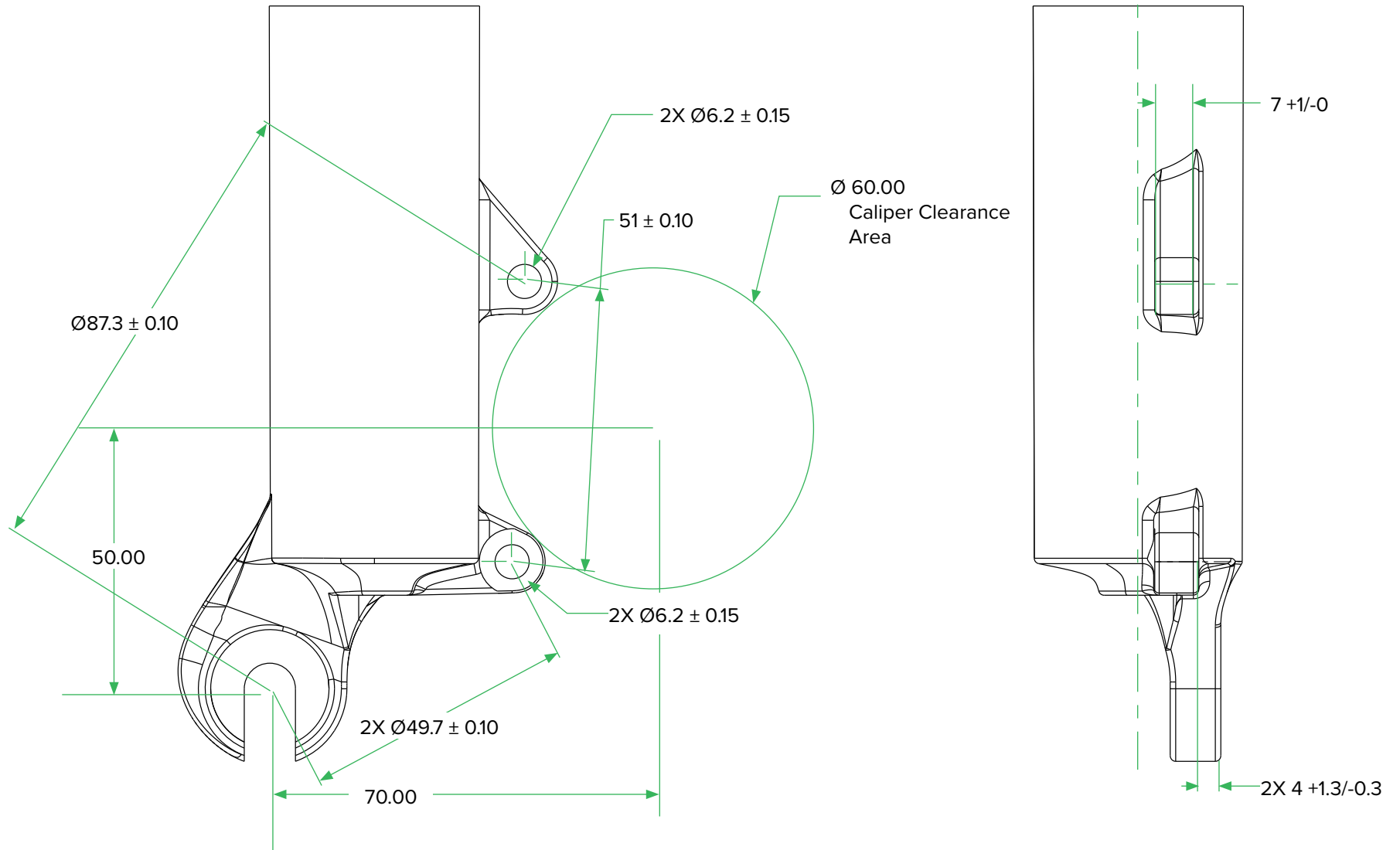

Post Mount Frame Specification

All SRAM Post Mount Calipers

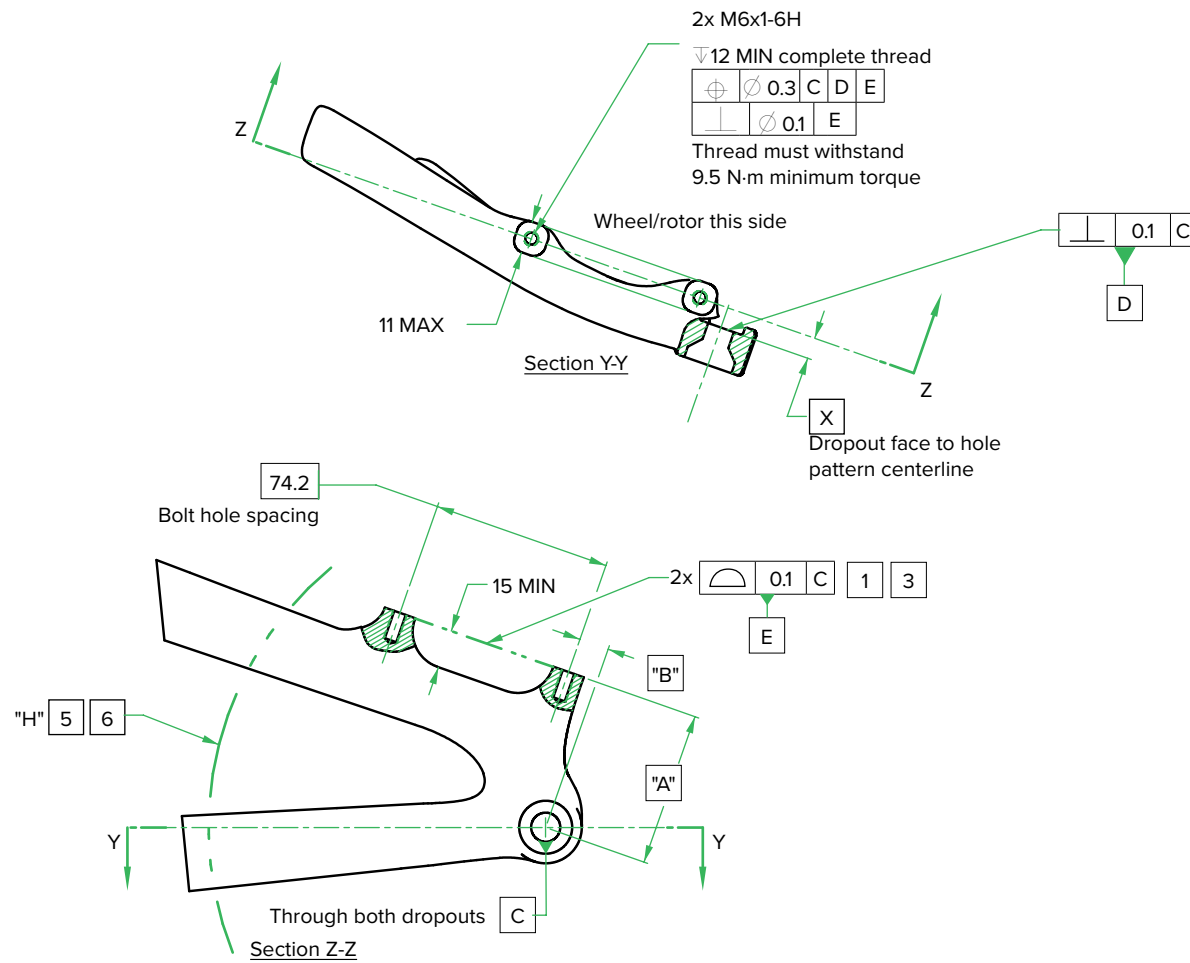

Rotor \varnothing (mm)	A	B	H (Radius)
140	47.24	1.8	140
160	55.9	6.8	150
180	64.56	11.8	160
200	73.22	16.8	170
203	73.9	18.8	172
220	81.88	21.8	180

Hub Standard	X
10x135 (QR)	5.7
12x142	
12x148 Boost	9.2
12x157 Super Boost	

- 1 There is potential for the fork and caliper interface to be exposed to high temperatures. This should be evaluated on all designs.
- 2 All dimensions and tolerances apply in free state and as assembled.
- 3 Surfaces must be free from paint.
- 4 All dimensions applied after paint unless otherwise specified.
- 5 All surfaces that come in contact with brake hose should be free of burrs and sharp edges.
- 6 Internal hose routing hole position radius "H" mm MIN from dropout \varnothing .

Flat Mount Thru Bolt Frame Specification

SRAM Flat Mount Calipers and 140/160/180/200/220 Rotor

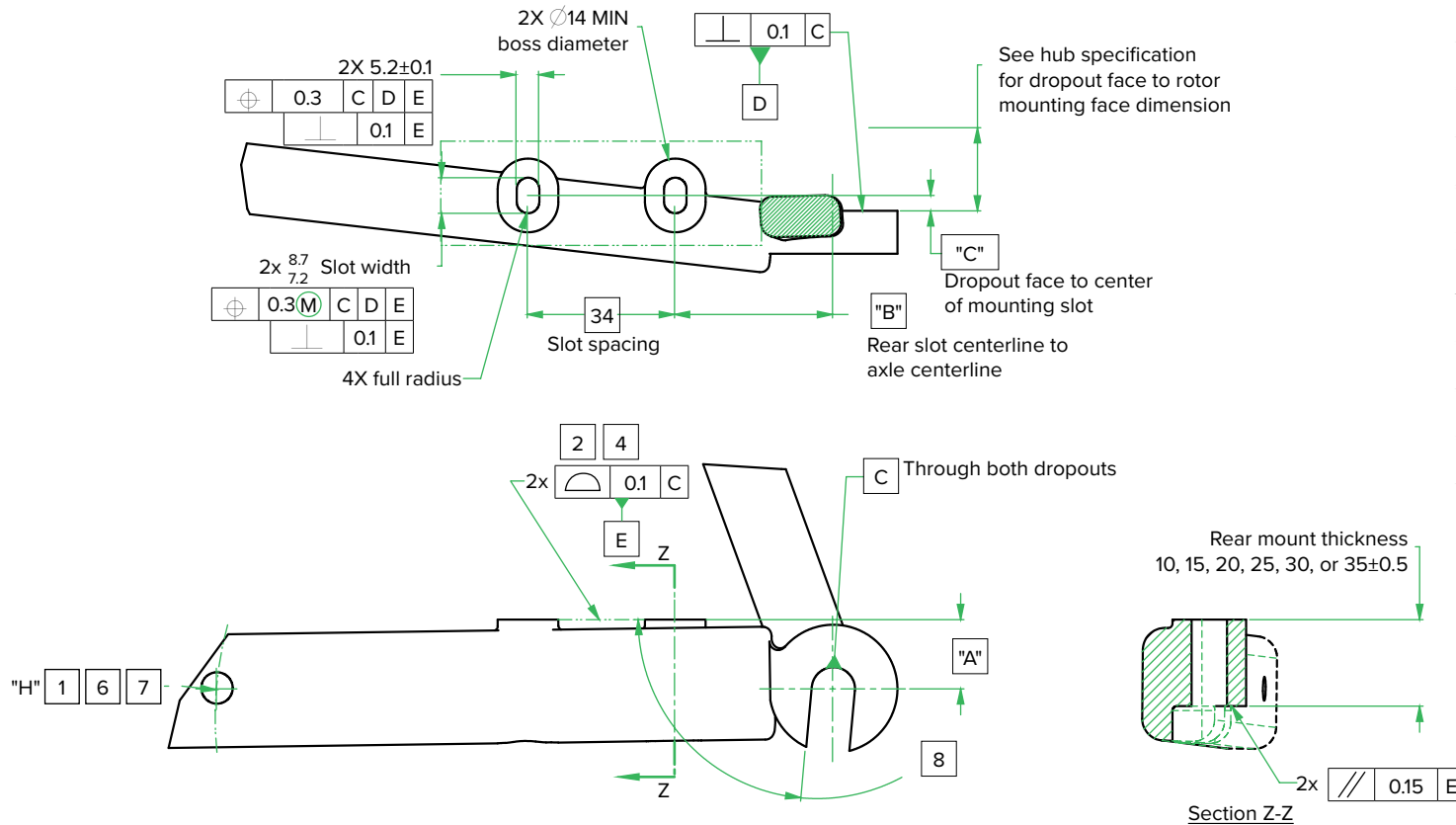

Rotor \varnothing (mm)	A	B	H (Radius)
140	16.0	36.5	140
160	21.0	45.0	150
180	26.0	53.5	160
200	31.0	62.0	170
220	36.0	70.5	180

Hub Spacing	C
135	3.55
142	7.05
148	
157	

- Minimum internal routing hole position does not apply to Connect-a-majig.
- There is potential for the fork and caliper interface to be exposed to high temperatures. This should be evaluated on all designs.
- All dimensions and tolerances apply in free state and as assembled.
- Surfaces must be free from paint.
- All dimensions applied after paint unless otherwise specified.
- All surfaces that come in contact with brake hose should be free of burrs and sharp edges.
- Internal hose routing hole position radius "H" mm MIN from dropout \perp
- Wheel installation may be impeded by rotor-to-caliper interference when wheel installation path approaches or is less than 69° .

Flat Mount Frame Specification

SRAM Flat Mount Calipers and 140/160/180/200/220 Rotor

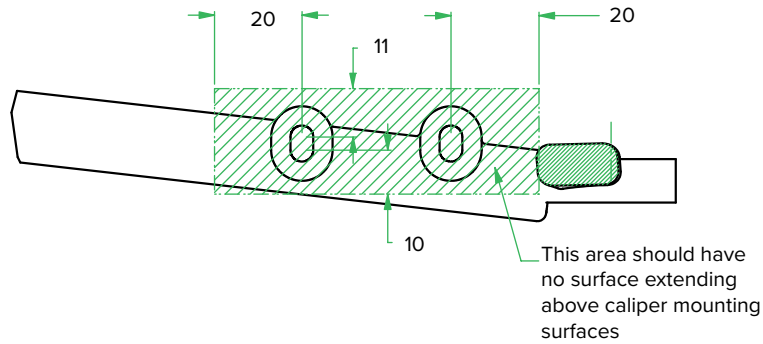

Surfaces shall not extend above caliper mounting surfaces (see envelope above)

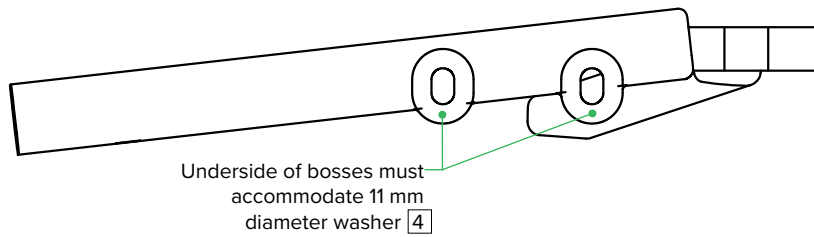
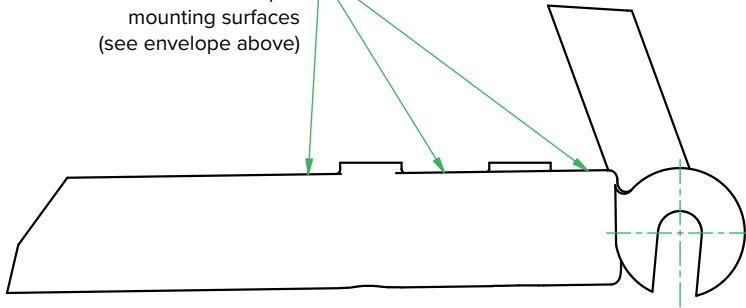

Flat Mount Caliper Frame Specification

Bolts and brackets may need to be purchased separately.

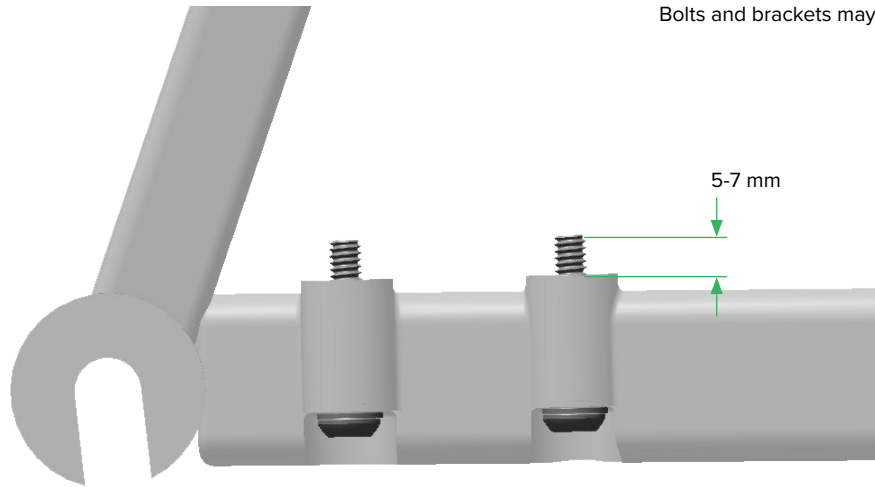

Note

1 Available in rear bolt lengths: 17, 22, 27, 32, 37, and 42 mm

⚠️ WARNING - CRASH HAZARD

There must be 5-7 mm of mounting bolt thread engagement when mounting brake calipers to forks and frames with flat mount hardware and brackets. Riding a bike with improper bolt engagement can allow the brakes to disengage from the bicycle, which can lead to a crash and serious injury or death to the rider.

Rear Flat 20F

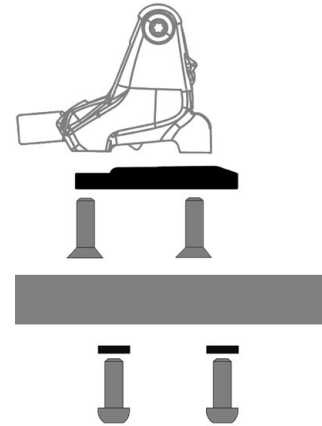

Chainstay Frame Thickness	Button Head Bolts	Flat Head Bolts
10 mm	17 mm	10.7 mm
15 mm	22 mm	10.7 mm
20 mm	27 mm	10.7 mm
25 mm	32 mm	10.7 mm
30 mm	37 mm	10.7 mm
35 mm	42 mm	10.7 mm

Rear Flat Direct- OF Direct

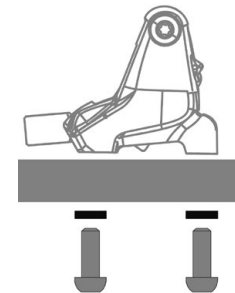

Chainstay Frame Thickness	Button Head Bolts
10 mm	17 mm
15 mm	22 mm
20 mm	27 mm
25 mm	32 mm
30 mm	37 mm
35 mm	42 mm

BB7/ BB5

Mechanical Disc Brake Clearance

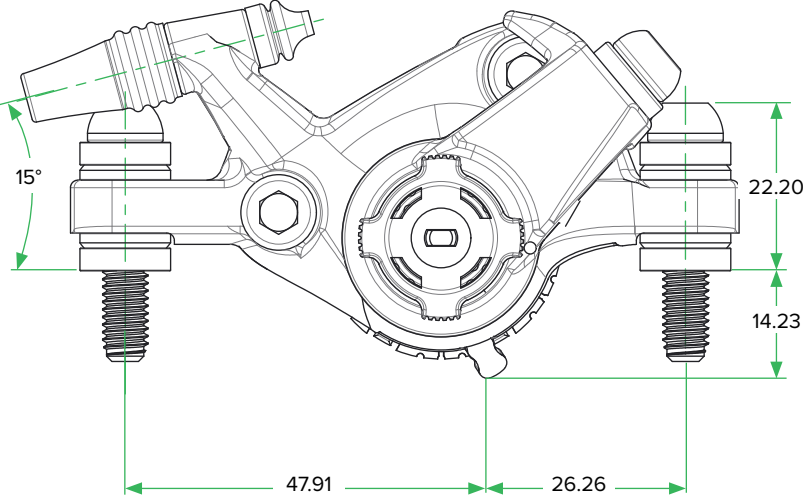
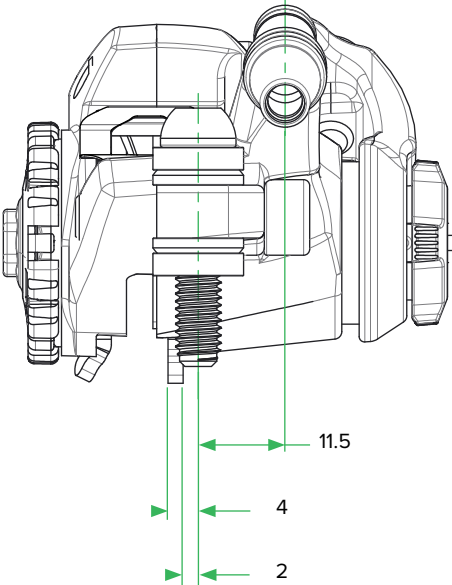

Mechanical Brake Specifications

Rear International Standard and Post Fork Mount

Caliper/Lever Compatibility				
Levers/Brakes	Shorty Ultimate	BB7 MTB & BB5 MTB	BB7 Road & BB5 Road	Hydraulic Disc
FR-5	—	X	—	—
Hydraulic	—	—	—	X
Road Brake Levers	X	—	X	—

Lever Cable Pull	Shorty Ultimate	BB7 MTB & BB5 MTB	BB7 Road & BB5 Road	Hydraulic Disc
Less than 20 mm	X	—	X	—
20 mm - 32 mm	—	X	—	—
Greater than 32 mm	—	X ¹	—	—

1 Brake levers with a cable pull of more than 32 mm are compatible with SRAM Single Digit, BB7 MTB, and BB5 MTB mechanical disc brakes, but reduce brake power.

Range of Adjustment	
	FR-5
Minimum Cable Pull	25 mm
Leverage Ratio	2:1
Maximum Cable Pull	29 mm
Leverage Ratio	2.75:1

Brake Boss Dimensions

Brake Post Length Standards	Dimension "L"
Post-2008 Shimano Standard	21.0 mm
Pre-2008 Shimano Standard	22.0 mm

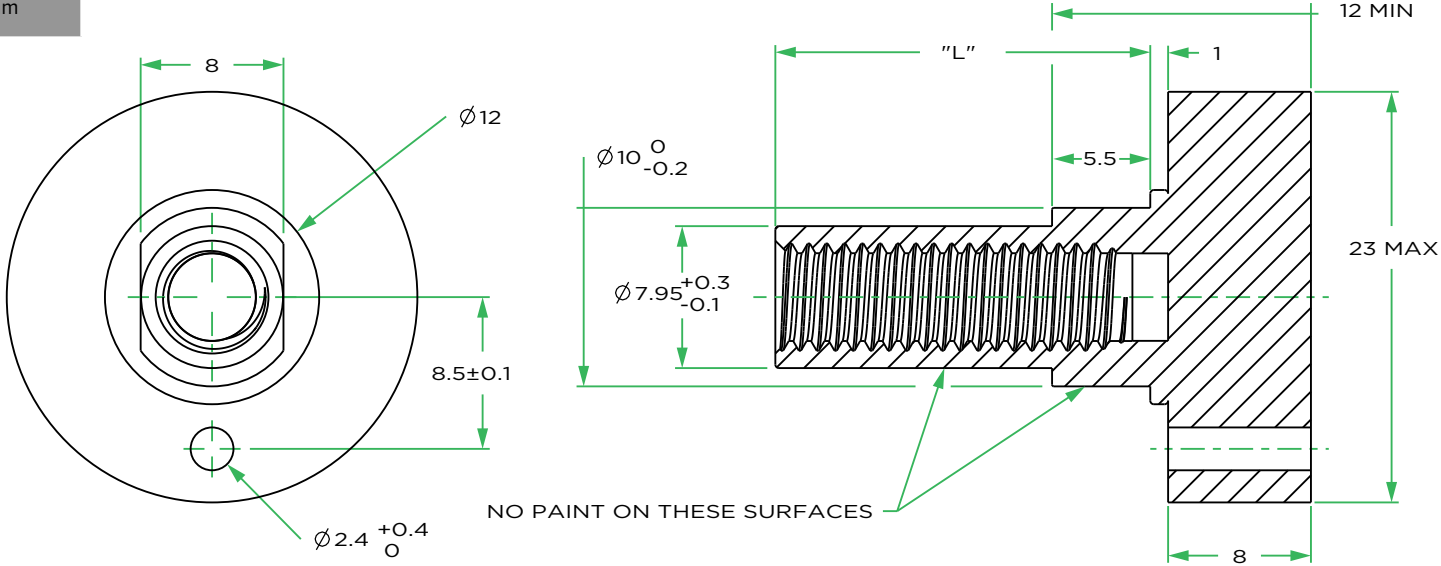

Shorty Ultimate

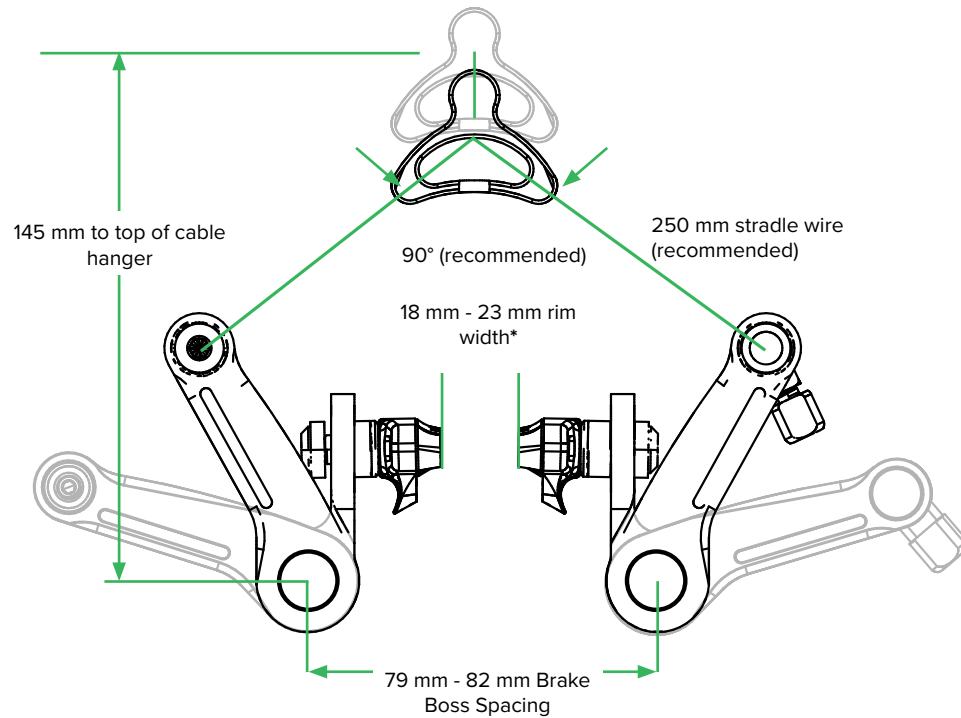

COMPATIBILITY

***Wheel rims wider than 23 mm (ex. Zipp 303 Cyclocross):**
Use aftermarket brake pad kit part number 00-5115-044-020.

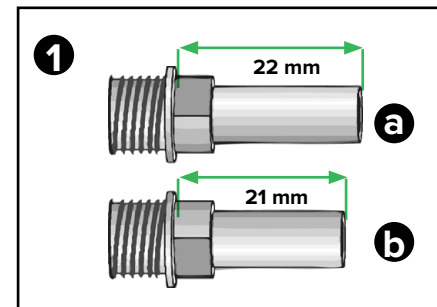

Measure Brake Boss

Measure your bicycle's brake bosses to determine which spacer configuration is required.

- 1 Measure the brake boss from the end of the brake boss to the shoulder.
22 mm: Use the black, 1 mm plastic spacers (a) that fit over the brake boss.
21 mm: Use the silver, 1 mm steel spacers (b) that fit over the mounting bolt threads.

Handlebar Specification

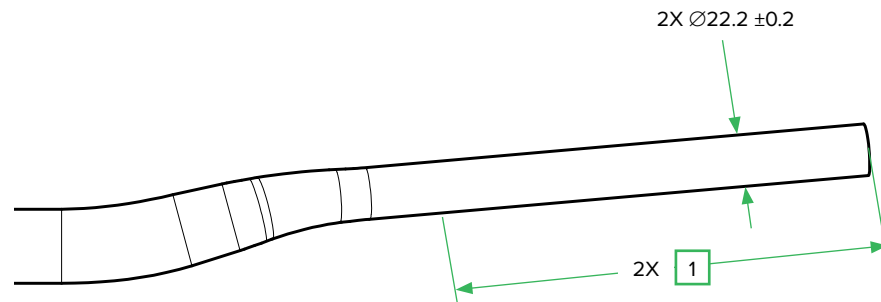

Notes

- 1 $\text{Ø}22.2$ shall extend far enough along the handlebar to accommodate grip.
- 2 All SRAM brake lever clamp styles will fit handlebars that conform to this specification.

Rotors

HS2

6-Bolt Rotor Dimensions

Rotor size	Radiused Outer Diameter	Rotor Thickness
	A (mm)	B (mm)
160	160	2
180	180	
200	200	
220	220	

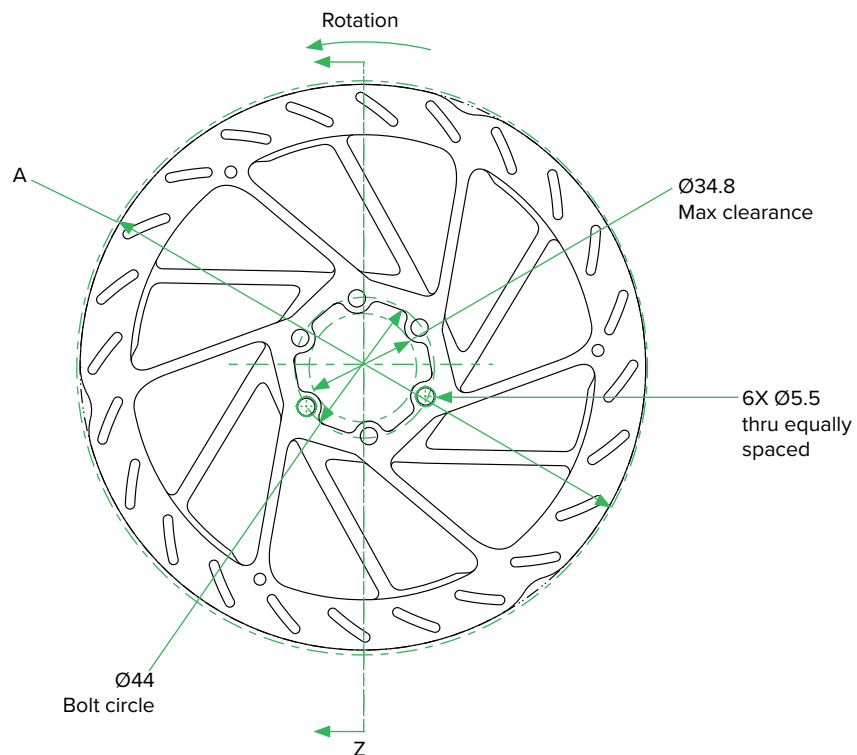

Section Z-Z

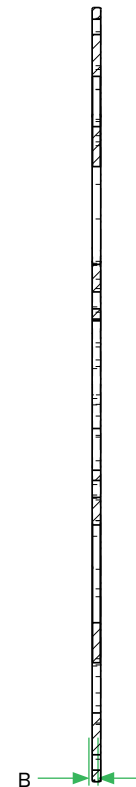

Note

- 1 Rotor mounting bolt torque value is 6.2 N-m (55 in-lb).

WARNING

- 2 Use only 10 mm length rotor bolts. Rotor bolts longer than 10 mm will not properly secure rotor and could damage the hub.

HS2

One-Piece Center Locking Rotor Dimensions

Rotor size	Radiused Outer Diameter	Rotor Thickness
	A (mm)	B (mm)
160	160	2
180	180	
200	200	
220	220	

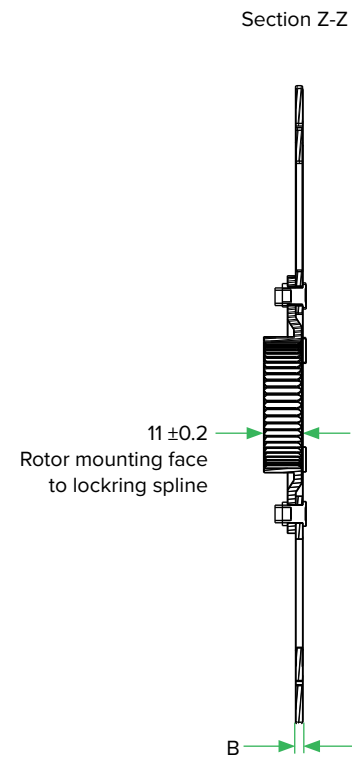
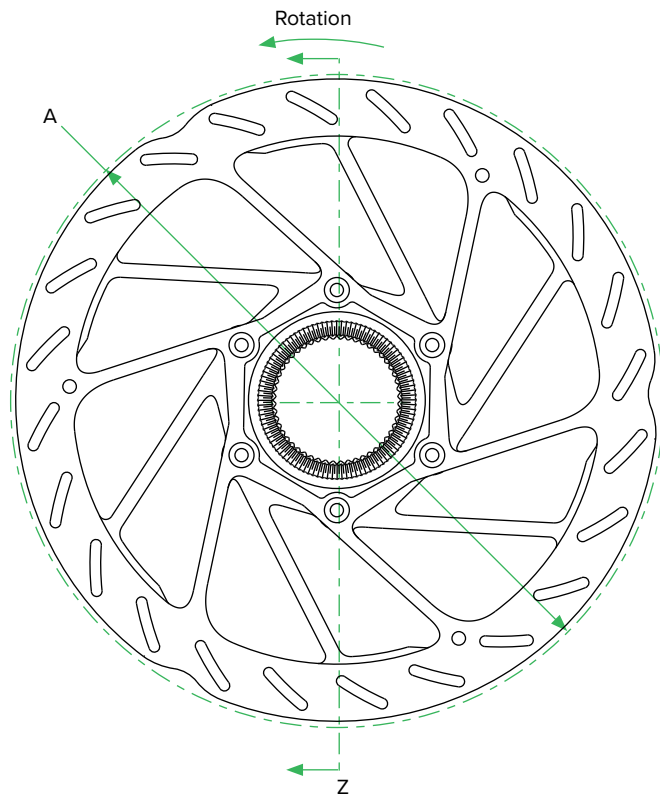

Note

- 1 SRAM locking torque is 40 N·m (354 in-lb).

CenterLine X

Two-Piece 6-Bolt Rotor Dimensions

Rotor size	Radiused Outer Diameter	Rotor Thickness	Carrier Diameter
	A (mm)	B (mm)	C (mm)
160	160	1.85	110.1
180	180	1.85	130.1

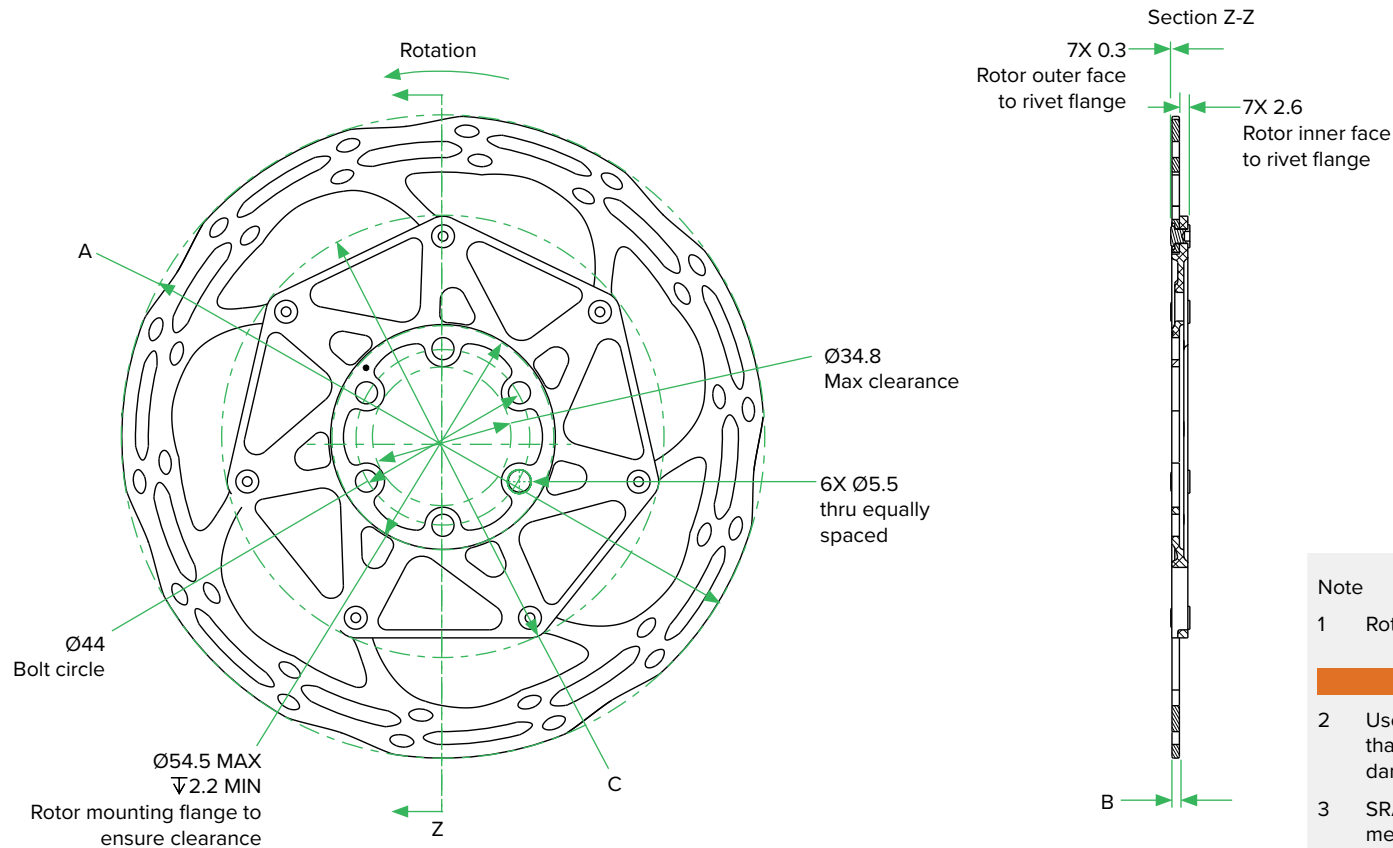

Note

- 1 Rotor mounting bolt torque value is 6.2 N·m (55 in·lb).

WARNING

- 2 Use only 10 mm length rotor bolts. Rotor bolts longer than 10 mm will not properly secure rotor and could damage the hub.
- 3 SRAM two-piece rotors are not approved for use with mechanical disc brakes.

CenterLine X

Two-Piece Center Locking Rotor Dimensions

Rotor size	Radiused Outer Diameter	Rotor Thickness	Carrier Diameter
	A (mm)	B (mm)	C (mm)
160	160	1.85	110.1
180	180	1.85	130.1

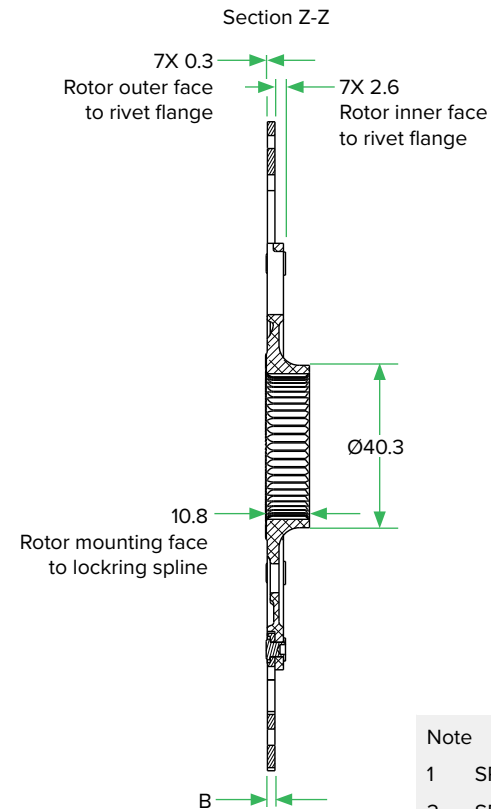
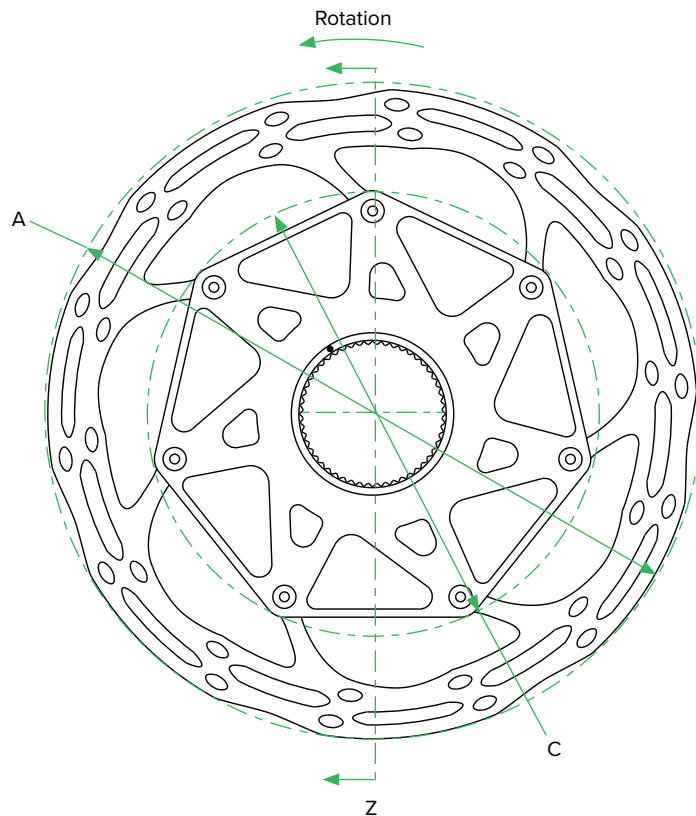

Note

- 1 SRAM locking torque is 40 N·m (354 in-lb).
- 2 SRAM two-piece rotors are not approved for use with mechanical disc brakes.

CenterLine XR

Two-piece 6-Bolt Rotor Dimensions

Rotor Size	Radiused Outer Diameter	Rotor Thickness	Carrier Diameter
	A (mm)	B (mm)	C (mm)
160	160	1.85	120

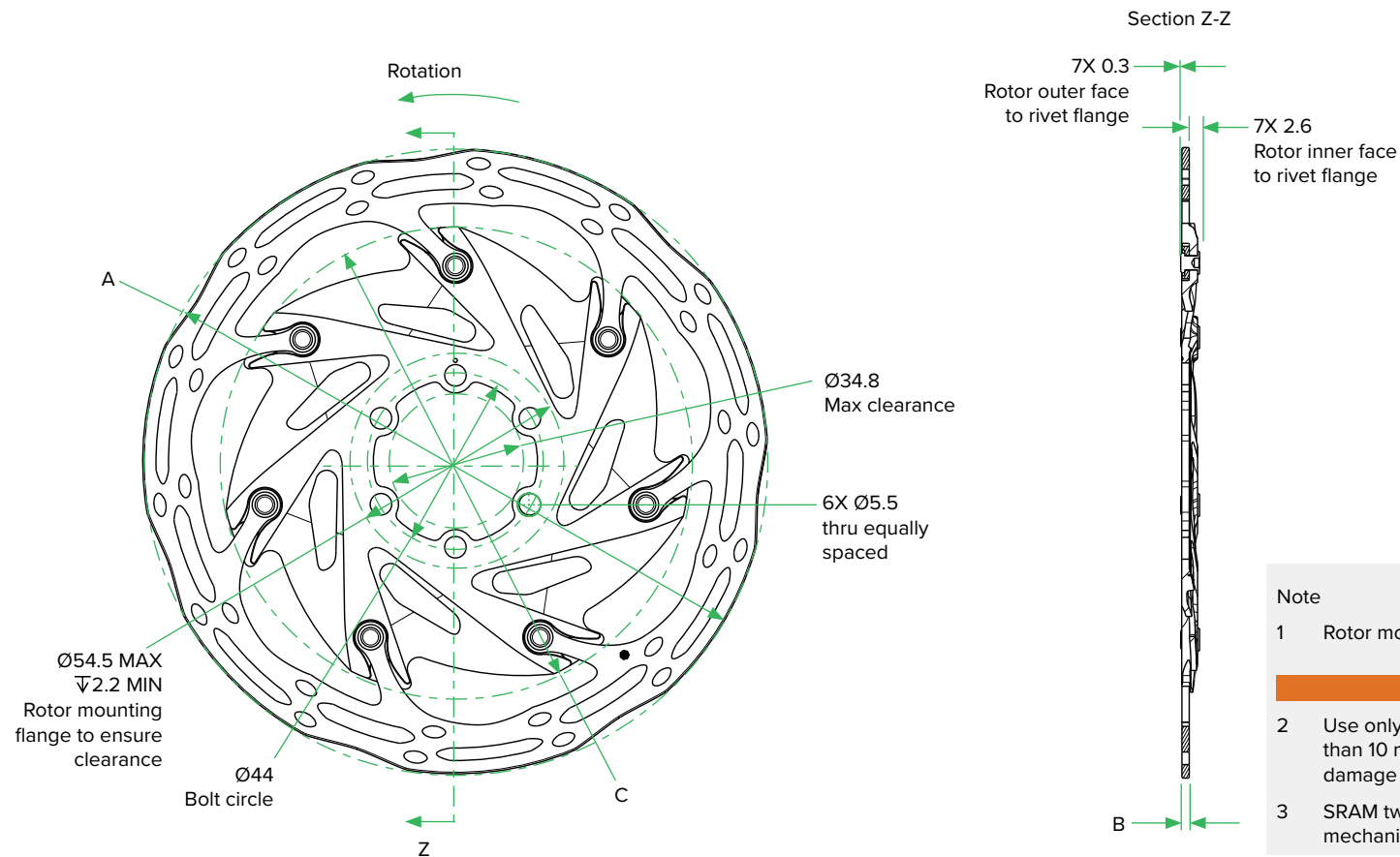

Note

- 1 Rotor mounting bolt torque value is 6.2 N·m (55 in-lb).

WARNING

- 2 Use only 10 mm length rotor bolts. Rotor bolts longer than 10 mm will not properly secure rotor and could damage the hub.
- 3 SRAM two-piece rotors are not approved for use with mechanical disc brakes.

CenterLine XR

Two-piece Center Locking Rotor Dimensions

Rotor Size	Radiused Outer Diameter	Rotor Thickness	Carrier Diameter
	A (mm)	B (mm)	C (mm)
160	160	1.85	120

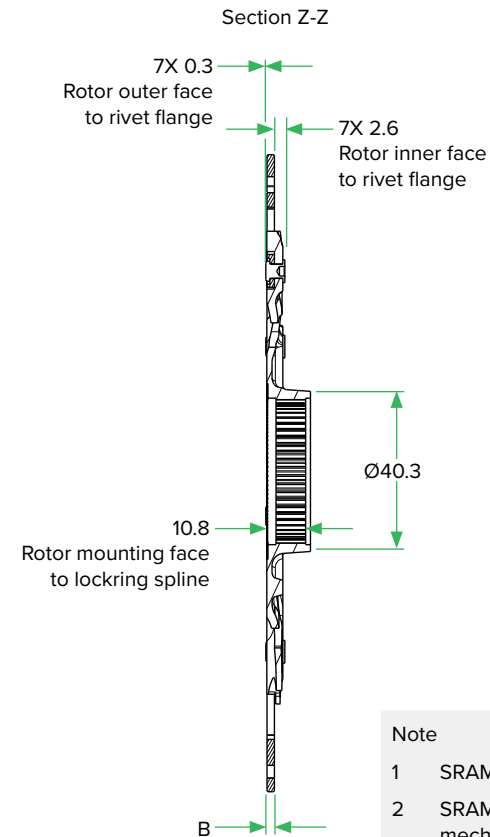
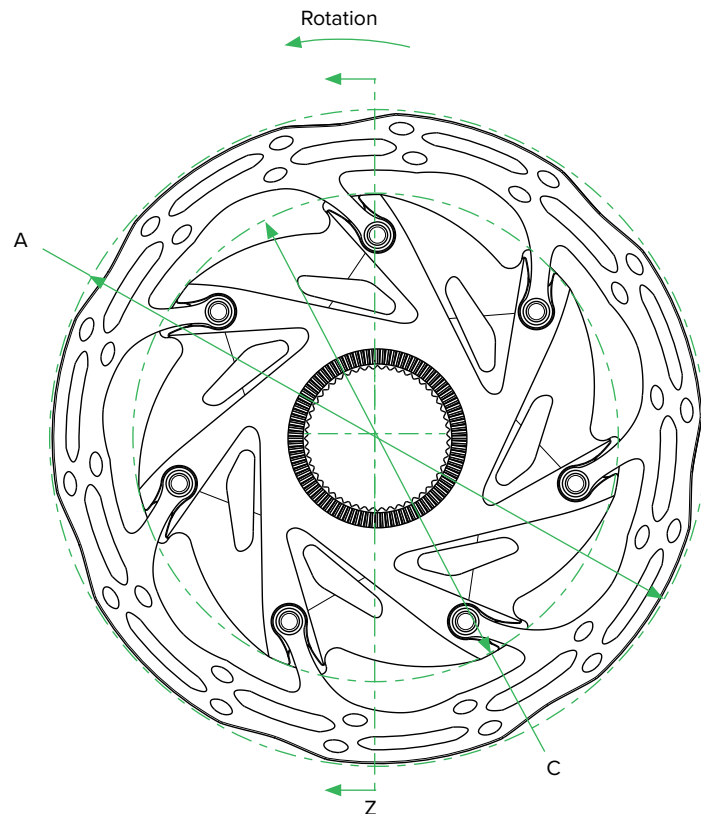

Note

- 1 SRAM locking torque is 40 N·m (354 in-lb).
- 2 SRAM two-piece rotors are not approved for use with mechanical disc brakes.

CenterLine

6-Bolt Rotor Dimensions

Rotor size	Radiused Outer Diameter	Rotor Thickness
	A (mm)	B (mm)
160	160	1.85
180	180	
200	200	
203	203	
220	220	2.0 non-radiused

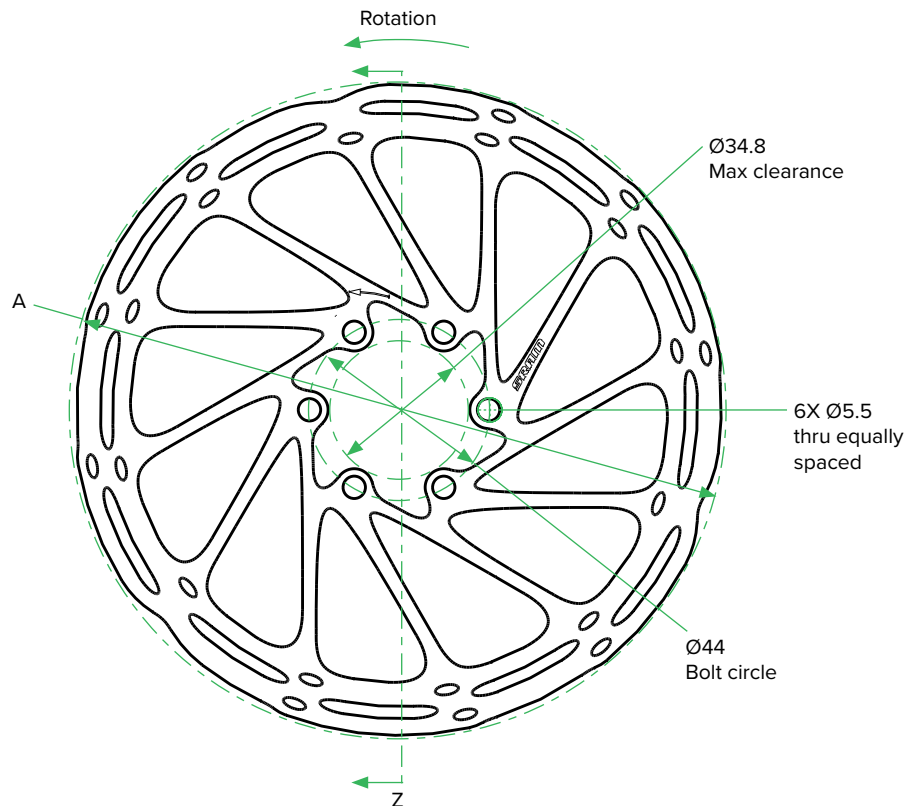

Section Z-Z

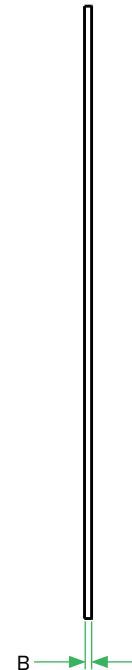

Note

- 1 Rotor mounting bolt torque value is 6.2 N-m (55 in-lb)..

⚠ WARNING

- 2 Use only 10 mm length rotor bolts. Rotor bolts longer than 10 mm will not properly secure rotor and could damage the hub.

CenterLine

One-Piece Center Locking Rotor Dimensions

Rotor size	Rotor Thickness	
	A (mm)	B (mm)
160	160	1.85
180	180	
200	200	

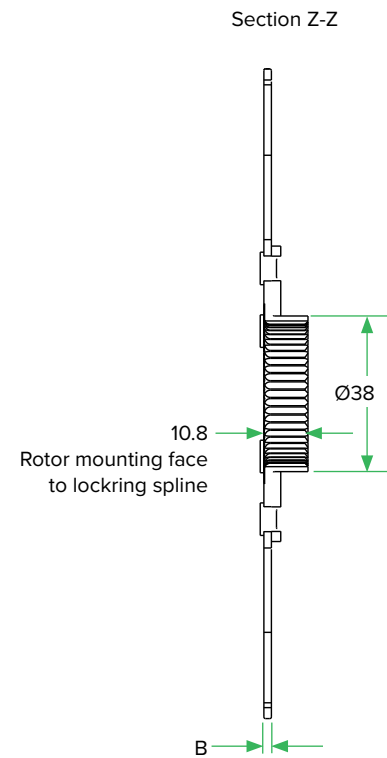
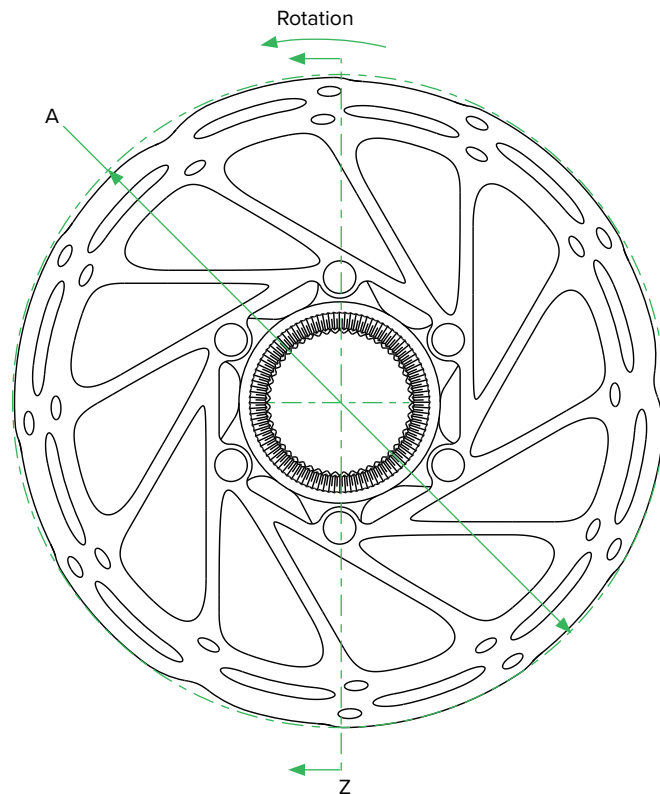

Note

1 SRAM locking torque is 40 N·m (354 in-lb).

Lockring for Center Locking Rotor

Specifications

Lockring Type	Thickness (mm)
Regular	3.7
Thin	2.1

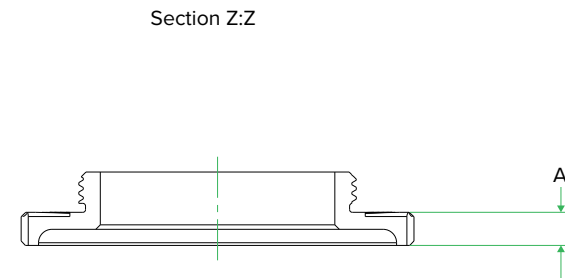
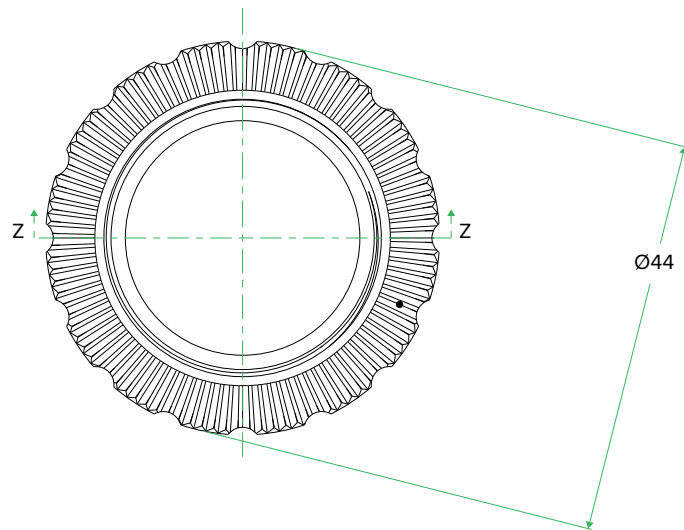

Note

- 1 SRAM lockring torque is 40 N·m (354 in-lb).
- 2 The Zipp lockring (thin) must be used with a 140 mm or 160 mm rotor.

Spoke Clearance

Rotor Size	Horizontal	Vertical
N/A	61 MAX	18.26 MIN
140	70	19.12
160	80	20.09
180	90	21.05
200	100	21.99
220	110	22.94

Note

- 1 Wheel designer to determine the safe clearance distance from the caliper to account for wheel flex and tolerance stack.
- 2 Caliper body will not extend beyond this datum. Datum accounts for caliper manufacturing tolerances and variation in pad advancement.
- 3 Caliper position shown for 160 mm rotor.

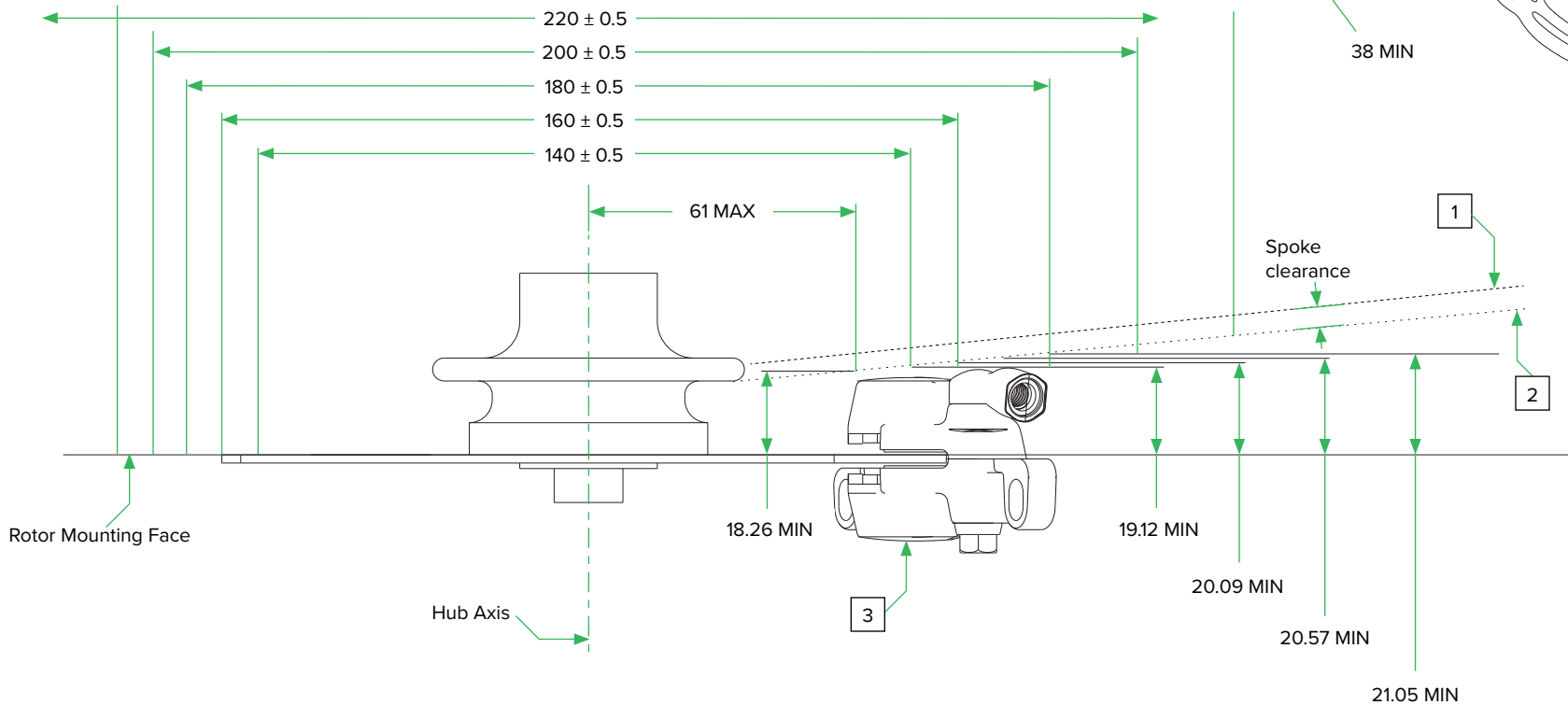
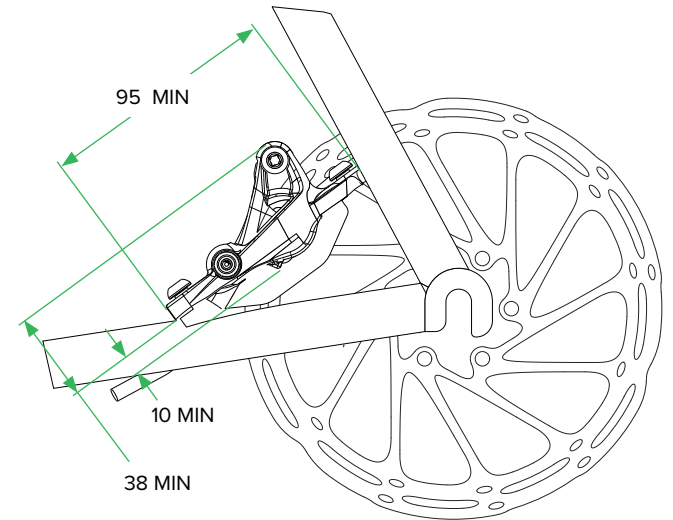

These are registered trademarks of SRAM, LLC:

1:1®, Accuwatt®, Avid®, ATAC®, AXS®, Bar®, Bioposition®, Blackbox®, BoXXer®, DoubleTap®, eTap®, Firecrest®, Firex®, Grip Shift®, GXP®, Holzfeller®, Hussefelt®, Icllic®, i-Motion®, Judy®, Know Your Powers®, NSW®, Omnium®, Osmos®, Pike®, PowerCal®, PowerLock®, PowerTap®, Qollector®, Quarq®, RacerMate®, Reba®, Rock Shox®, Ruktion®, Service Course®, ShockWiz®, SID®, Single Digit®, Speed Dial®, Speed Weaponry®, Spinscan®, SRAM®, SRAM APEX®, SRAM EAGLE®, SRAM FORCE®, SRAM RED®, SRAM RIVAL®, Stylo®, TIME®, Truvativ®, TyreWiz®, UDH®, Varicrank®, Velotron®, X0®, X01®, X-SYNC®, XX1®, Zipp®

These are registered logos of SRAM, LLC:



These are trademarks of SRAM, LLC:

10K™, 1X™, 202™, 30™, 30 Course™, 35™, 302™, 303™, 353™, 404™, 454™, 808™, 858™, 3ZERO MOTO™, ABLC™, AeroGlide™, AeroBalance™, AeroLink™, Aire™, Air Guides™, AKA™, AL-7050-TV™, Atmos™, Automatic Drive™, AxCad™, Axial Clutch™, Base™, BB5™, BB7™, BB30™, Bleeding Edge™, Blipbox™, BlipClamp™, BlipGrip™, Blips™, Bluto™, Bottomless Tokens™, Cage Lock™, Carbon Bridge™, Centera™, Charger 2™, Charger™, Charger Race Day™, Cleansweep™, Clickbox Technology™, Clics™, Code™, Cognition™, CoLab™, Connectamajig™, Counter Measure™, CYCLO™, DD3™, DD3 Pulse™, DebonAir™, Deluxe™, Deluxe Re:Aktiv™, Descendant™, DFour™, DFour91™, DH™, Dig Valve™, DirectLink™, Direct Route™, Domain™, DOT 5.1™, Double Decker™, Double Time™, Dual Flow Adjust™, Dual Position Air™, DUB™, DUB-PWR™, DZero™, E300™, E400™, Eagle™, E-Connect4™, ErgoBlade™, ErgoDynamics™, ESP™, EX1™, Exact Actuation™, Exogram™, Flight Attendant™, Flow Link™, FR-5™, Full Pin™, G2™, G40™, Giga Pipe™, Gnar Dog™, Guide™, GS™, GX™, Hard Chrome™, Hexfin™, HollowPin™, Howitzer™, HRD™, Hybrid Drive™, Hyperfoil™, i-3™, Impress™, Jaws™, Jet™, Kage™, Komfy™, LINK™, Lyrik™, MatchMaker™, Maxle™, Maxle 360™, Maxle DH™, Maxle Lite™, Maxle Lite DH™, Maxle Stealth™, Maxle Ultimate™, Micro Gear System™, Mini Block™, Mini Cluster™, Monarch™, Monarch Plus™, Motion Control™, Motion Control DNA™, MRX™, MX™, Noir™, NX™, OCT™, OmniCal™, OneLoc™, Paceline™, Paragon™, PC-1031™, PC-110™, PC-1170™, PG-1130™, PG-1050™, PG-1170™, Piggyback™, Poploc™, Power Balance™, Power Bulge™, PowerChain™, PowerDomeX™, Powered by SRAM™, PowerGlide™, PowerLink™, Power Pack™, Power Spline™, Predictive Steering™, Pressfit™, Pressfit 30™, Prime™, Qalvin™, R2C™, Rapid Recovery™, Re:Aktiv ThruShaft™, Recon™, Reverb™, Revelation™, Riken™, Roller Bearing Clutch™, Rolling Thunder™, RS-1™, Rush™, RXS™, Sag Gradients™, Sawtooth™, SCT - Smart Coasterbrake Technology, Seeker™, Sektor™, SHIFT™, ShiftGuide™, Shorty™, Showstopper™, SIDLuxe™, Side Swap™, Signal Gear Technology™, SL™, SL-70™, SL-70 Aero™, SL-70 Ergo™, SL-80™, SI-88™, SLC2™, SL SPEED™, SL Sprint™, Smart Connect™, Solo Air™, Solo Spoke™, Speciale™, SpeedBall™, Speed Metal™, SRAM APEX 1™, SRAM Force 1™, SRAM RIVAL 1™, S-series™, Stealth-a-majig™, StealthRing™, Super-9™, Supercork™, Super Deluxe™, Super Deluxe Coil™, SwingLink™, SX™, Tangente™, TaperCore™, Timing Port Closure™, TSE Technology™, Tool-free Reach Adjust™, Top Loading Pads™, Torque Caps™, TRX™, Turnkey™, TwistLoc™, VCLC™, Vivid™, Vivid Air™, Vuka Aero™, Vuka Alumina™, Vuka Bull™, Vuka Clip™, Vuka Fit™, Wide Angle™, WIFLI™, X1™, X3™, X4™, X5™, X7™, X9™, X-Actuation™, XC™, X-Dome™, XD™, XDR™, XG-1150™, XG-1175™, XG-1180™, XG-1190™, X-Glide™, X-GlideR™, X-Horizon™, XLoc Sprint™, XPLR™, XPRESSO™, XPRO™, X-Range™, XX™, Yari™, ZEB™, Zero Loss™, ZM2™, ZR1™



Specifications and colors subject to change without prior notice.

© 2023 SRAM, LLC

This publication includes trademarks and registered trademarks of the following companies:

BOOST™ is a trademark owned by Trek Bicycle Corporation.

ASIAN HEADQUARTERS

SRAM Taiwan
No. 1598-8 Chung Shan Road
Shen Kang Hsiang, Taichung City
Taiwan R.O.C.

WORLD HEADQUARTERS

SRAM LLC
1000 W. Fulton Market, 4th Floor
Chicago, Illinois 60607
U.S.A.

EUROPEAN HEADQUARTERS

SRAM Europe
Paasbosweg 14-16
3862ZS Nijkerk
The Netherlands